

Location: _____



MI-E-O

ELECTRONIC OIL INTERCEPTOR

Specification: MIFAB® Series MI-E-O _____ sanitary powder epoxy coated inside and outside fabricated 10 gauge steel electronic oil interceptor. Unit to include: sediment bucket with perforated baffle near inlet, deep seal trap covered by lid, sewer gas stopper, securing bolt(s), removable baffle assembly and cross bar, stainless steel calibrated orifice plate, internal air relief by-pass, adjustable automatic draw-off assembly, double vent connection on each side, and steel powder epoxy coated, non skid rectangular lid(s).

Function: Use in parking garages, service stations, and maintenance areas to receive wastewater that contains oil and sediment. The interceptor collects the oil before it is drained to an adjacent storage tank through an adjustable draw off system. Sediment and debris is collected inside of the internal sediment bucket. Regular maintenance is required to keep the interceptor functioning. Interceptor may be installed on the ground, semi recessed or flush with the floor. Sewer gas stopper prevents foul odors from entering the kitchen area through the interceptor.

Function: MIFAB's electronic oil interceptor monitors the oil level within the interceptor. The control box is weatherproof NEMA 4/4X rated, 120VAC connection, 360 degree viewable alarm light, a solid tone alarm, test switch and mute switch that closes the motorized butterfly valve when the float switch detects that the oil level is at 75% capacity. The closed inlet prevents additional oil from entering the interceptor and from discharging into the piping system. The operator must remove the lid of the interceptor and remove the accumulated oil and clean off the float switch to ensure that the motorized butterfly valve opens and regular operation can resume.

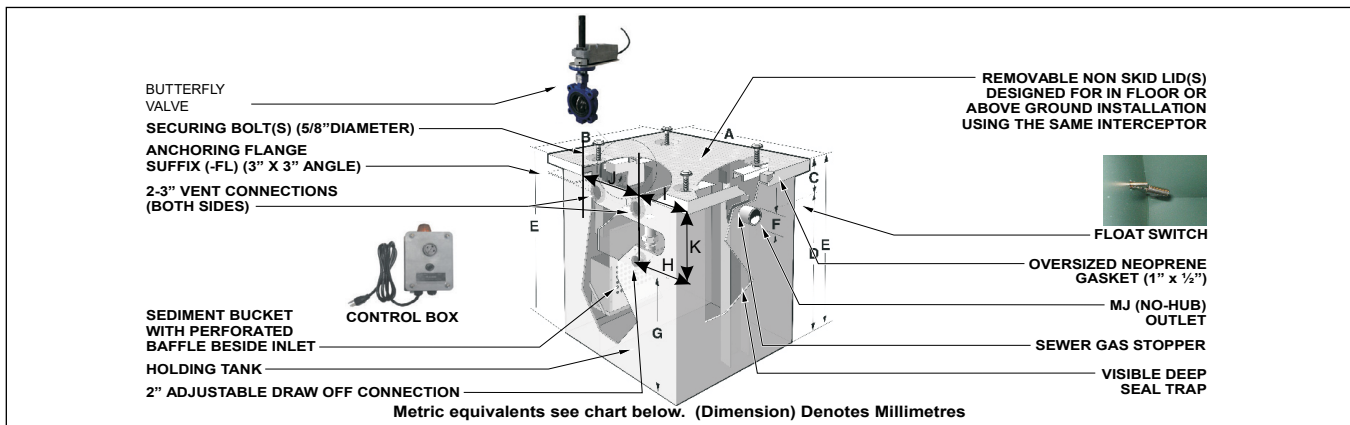

Note: The "C" dimension detailed above is from either the middle of the inlet or the outlet to the top the interceptor. The inlet and outlet dimensions are always the same.

MODEL NO.	US GPM	A IN	B IN	C IN	D IN	E IN	F IN	G IN	H (1) IN	I IN	J IN	K IN	HOLDING CAPACITY		NO. OF LIDS	NO. OF BOLTS
													U.S.G. (of liquid)	CU.FT (of liquid)		
MI-E-O-A	10	21.25	15.75	7.5	9.5	17	2	4	4	5.625	10	3.5	7	1.00	1	1
MI-E-O-B	15	23.75	15.75	7.5	11.5	19	2	6	4	6.875	10	3.5	9	1.20	1	1
MI-E-O-C	20	23.75	15.75	7.5	14	17.5	3	8	4	6.875	10	3.5	10	1.35	1	1
MI-E-O-1	25	28	22	7.5	26	21.5	3	19	4	9	10	4	47	6.25	1	4
MI-E-O-2	35	34	24	7.5	26	33.5	3	19	4	12	10	4	63	8.40	1	4
MI-E-O-3	50	34	24	7.5	28	33.5	3	21	4	12	10	4	69	9.10	1	4
MI-E-O-4	75	48	34	8	28	35.5	4	21	4	9	10	4	150	19.98	2	8
MI-E-O-5	100	51	36	8	28	36	4	21	4	20.5	10	4	171	22.76	2	8
MI-E-O-6	125	53	36	8	28	37	4	21	4	21.5	10	4	186	24.73	2	8
MI-E-O-7	150	58	36	10	28	38	4	21	4	24	10	4	215	28.60	3	12
MI-E-O-8	200	68	38	10	32	42	4	25	4	29	10	4	322	42.88	4	8
MI-E-O-9	250	74	40	12	38	50	4	31	4	32	10	4	401	53.44	4	8

Note: Reduce the "A" and "B" dimensions by 1" (25) to determine the actual body length and width dimensions. The lid overhangs the body by 1/2" (13) on all four sides.

SUFFIX	OPTIONAL VARIATIONS
-AL	Aluminum lid(s)
-AP	Anode pack
-BA	Buy American Act compliant product
-C	Extension "C" as required
specify	Special size inlet and outlet
-DW	Double wall containing interceptor and holding tank
DWHT	Double wall contained holding tank

-FL	Anchor flange
-FLC	Flow control fitting
-FLM	Anchor flange and membrane clamp
-HD	Heavy Duty load rated lids
-HLA	High level alarm
-HT	Holding tank to receive waste oil
-SS	Stainless steel cover shroud
-T	F.I.P. female threaded inlet and outlet
-TL	Lid (s) to receive tile or terrazzo

CALIFORNIA PROPOSITION 65 WARNING. This product contains chemicals known to the State of California to cause cancer and birth defects or other reproductive harm.

Job Name: _____ Page No: _____
 Section No: _____ Contractor: _____
 Schedule No: _____ Purchase Order No: _____