

FIXTURE SUPPORTS



CUSTOMER DRIVEN SINCE 1926

FIG. 0720, 0722, 0723, 0727, 0728 LAVATORY SUPPORTS WALL MOUNTED TYPE FOR HIGH BACK LAVATORIES—SINGLE SUPPORT

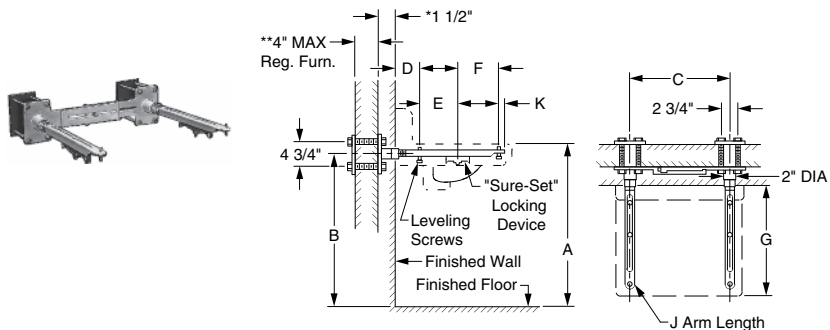

Fig. 0720

- * This dimension can be increased when required. (Specify thickness)
- **For greater wall thickness, longer supporting studs can be furnished. (Specify wall thickness)

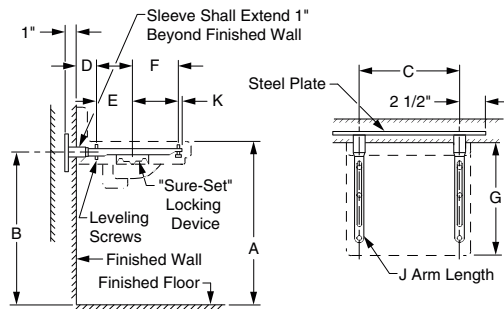

Fig. 0722

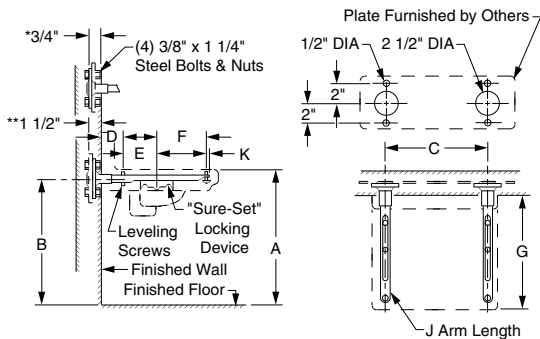

Fig. 0723

- * Arm support bracket shown bolted in back of wall plate for plaster wall construction.
- **Arm support bracket shown bolted in front of wall plate for tile wall construction.

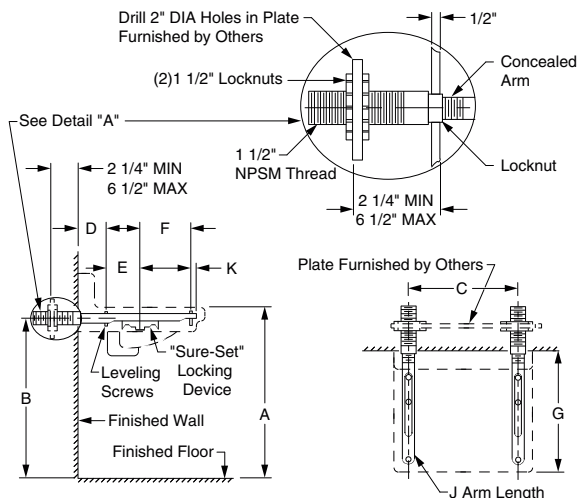

Fig. 0727

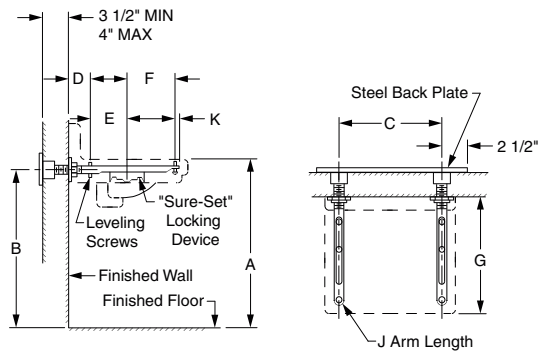

Fig. 0728

For lettered dimensions contact factory.

FIGURE NO.	DESCRIPTION	PRICE	APPROX. WT. LBS.
0720	Set on Masonry or Stud Wall	585.00	22
0722	Set on Steel Plate Secured in Wall	458.00	22
0723	To Attach to Backing Plate Secured in Wall	458.00	22
0727	Using Adjustable Extension	585.00	23
0728	Set on Steel Plate Secured to Glazed Block Wall	585.00	24

NOTE: Service weight regularly furnished on fittings above.
NOTE: Always specify fixture manufacturer's model name and number.

FIXTURE SUPPORTS

FIG. 0720E, 0722E, 0723E, 0727E, 0728E LAVATORY SUPPORTS WALL MOUNTED TYPE FOR FLAT SLAB LAVATORIES—SINGLE SUPPORT



FIXTURE SUPPORTS

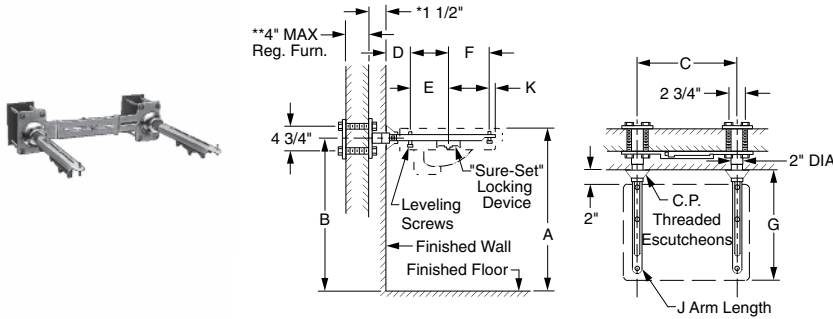

Fig. 0720E

* This dimension can be increased when required. (Specify thickness)
 **For greater wall thickness, longer supporting studs can be furnished. (Specify wall thickness)

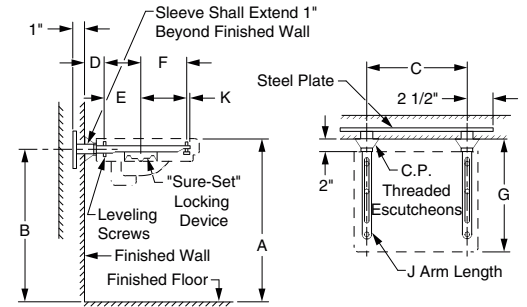

Fig. 0722E

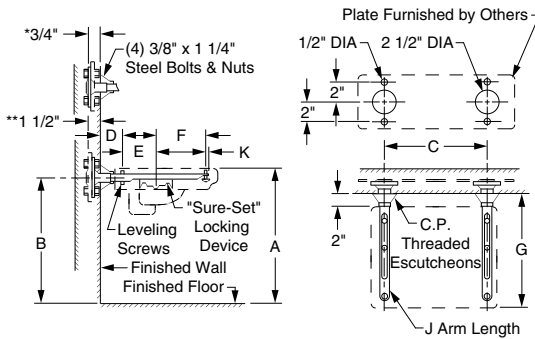

Fig. 0723E

* Arm support bracket shown bolted in back of wall plate for plaster wall construction.
 ** Arm support bracket shown bolted in front of wall plate for tile wall construction.

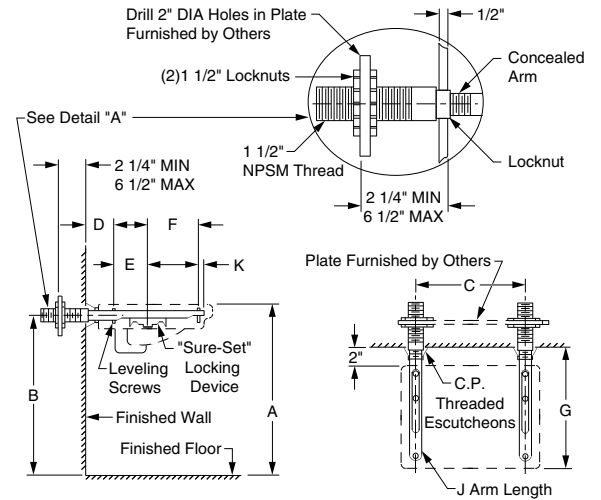

Fig. 0727E

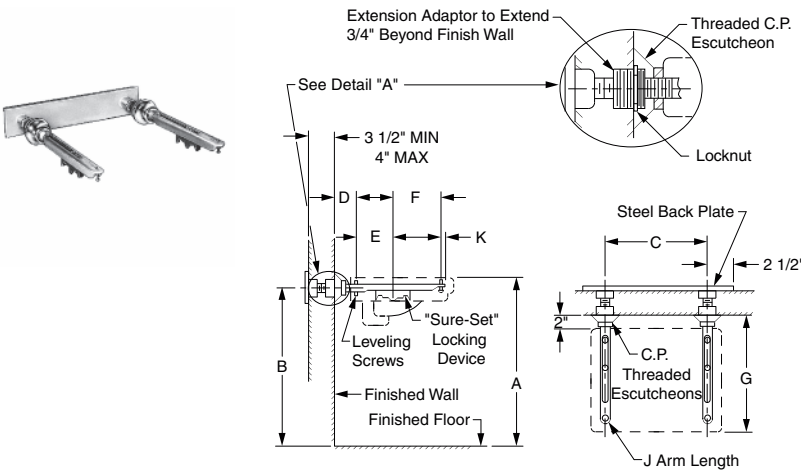

Fig. 0728E

For lettered dimensions contact factory.

FIGURE NO.	DESCRIPTION	PRICE	APPROX. WT. LBS.
0720E	Set on Masonry or Stud Wall	748.00	24
0722E	Set on Steel Plate Secured in Wall	623.00	24
0723E	To Attach to Backing Plate Sec'd in Wall	623.00	24
0727E	Using Adjustable Extension	750.00	25
0728E	Set on Steel Plate Secured to Glazed Block Wall	750.00	26

NOTE: Service weight regularly furnished on fittings above.
 NOTE: Always specify fixture manufacturer's model name and number.