

A132.8-VR Series
Barrier Free, Wall Mounted Electric Drinking Fountain
with Vandal Resistant Buttons



* U.S. DESIGN PATENT D545,607 (Bowl Design)

A132408S-VR / A132408S-VR-SO

TECHNICAL ASSISTANCE TOLL FREE TELEPHONE NUMBER:
1.800.591.9360

Technical Assistance Fax: 1.626.855.4894

NOTES TO INSTALLER:

1. Please leave this documentation with the owner of the fixture when finished.
2. Please read this entire booklet before beginning the installation.
3. Check your installation for compliance with plumbing, electrical and other applicable codes.

LIMITED WARRANTY - UNITED STATES & CANADA

Murdock warrants that every cooler, bottle filling station, packaged water chiller, fountain and accessory to be free from defects in material and workmanship under normal use for one (1) year from date of install or eighteen (18) months after the date of shipment from the factory, whichever comes first.

Murdock warrants the compressor and hermetically sealed refrigeration system, including cooling coil assembly when part of the hermetically sealed refrigeration system, to be free from defects in material and workmanship under normal use for an additional four (4) years from the end of the one (1) year period described above.

This warranty does not cover installation or labor charges and does not apply to materials, which have been damaged by other causes such as mishandling or improper care or abnormal use. The repair or replacement of the defective materials shall constitute the sole remedy of the Buyer and the sole remedy of Murdock under this warranty. Murdock shall not be liable under any circumstances for incidental, consequential or direct charges caused by defects in the materials, or any delay in the repair or replacement thereof. This warranty is in lieu of all other warranties expressed or implied. Product maintenance instructions are issued with each unit and disregard or non-compliance with these instructions will constitute an abnormal use condition and void the warranty. Stainless steel must be protected on job site during construction and must be properly maintained after the water has been introduced into the water cooler or drinking fountain, or Murdock's limited warranty is void.

LIMITED EXPORT WARRANTY - One year on parts only.

Murdock assumes no responsibility for use of void or suspended data. © Copyright Murdock, City of Industry, CA Member of Morris Group International. Please visit www.murdockmfg.com for most current specifications.

COMPLIES WITH
STANDARDS



NSF/ANSI 61



murdock[®]
SINCE 1853

Member of

MORRIS GROUP
INTERNATIONAL

15125 Proctor Ave, City of Industry,
CA, 91746 U.S.A.
Phone 800-591-9360
626-336-4561
Fax 626-855-4894

www.murdockmfg.com

IMPORTANT

This fixture is intended to dispense water that has been lowered in temperature, but otherwise remains unchanged by the materials in the water cooler. It is common for electrical equipment to be grounded to water lines either within a structure or away from it. Every attempt should be made to prevent this kind of grounding from generating electrical feedback into the water cooler creating electrolysis. Electrolysis will cause a metallic taste or cause water metal content to increase.

NOTICE

A dielectric coupling must be used to connect the water cooler to the water supply. A nonmetallic coupler is furnished with this water cooler to meet this requirement.

ROUGHING-IN AND DIMENSIONAL DRAWING

Prior to roughing consult with local, state, and federal codes for proper mounting height.

A132408S-VR Refrigerated Bi-Level Wall Mounted Drinking Fountain

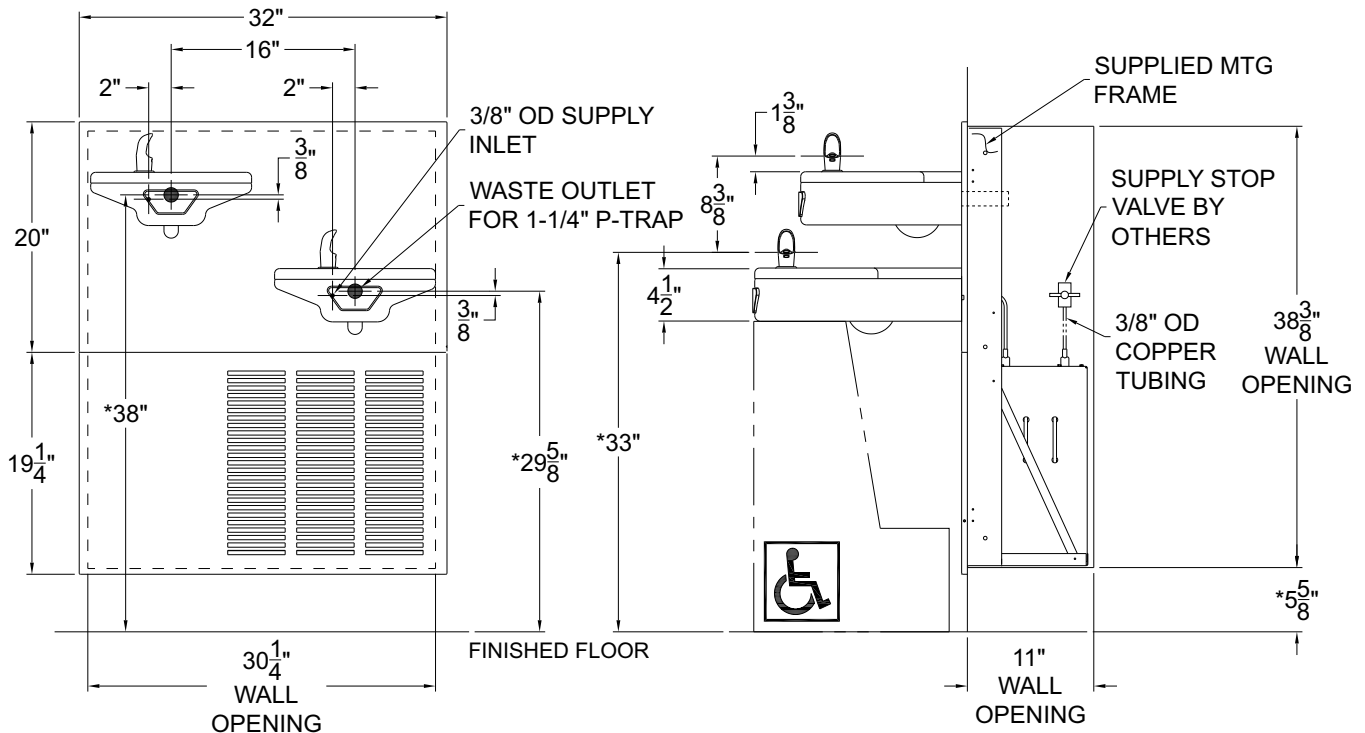

GENERAL NOTES:

1. ALL DIMENSIONS ARE IN INCHES [MM]
- *2. DIMENSIONS SHOWN ARE FOR RECOMMENDED ADULT HEIGHT. ADJUST VERTICAL DIMENSIONS AS NECESSARY TO COMPLY WITH FEDERAL, STATE, & LOCAL CODES
3. WATER LINE FROM CHILLER TO FOUNTAIN SHOULD BE COVERED WITH SPONGE FOAM RUBBER OR ICE WATER TYPE INSULATION OF ADEQUATE THICKNESS

A132408S-VR Refrigerated Reverse Bi-Level Wall Mounted Drinking Fountain

Note: There are no mounting changes to be made for -SO models.

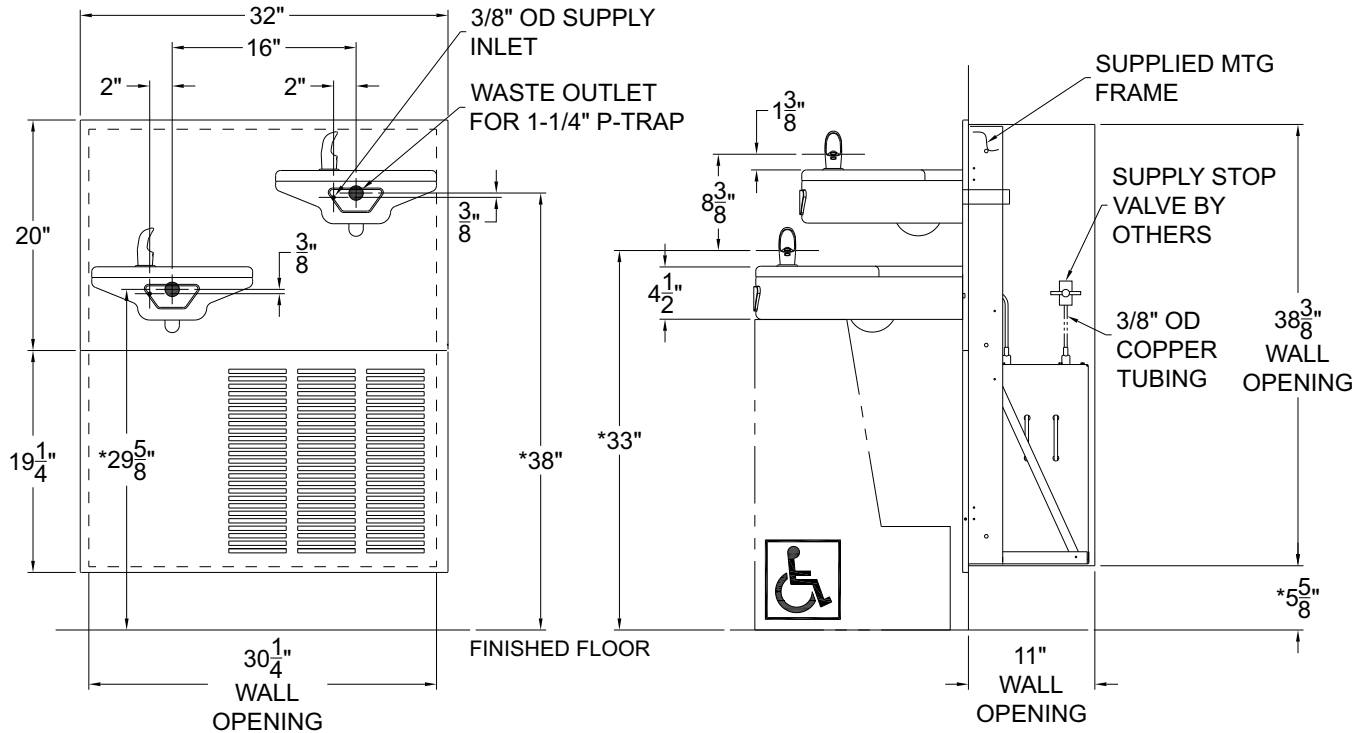

GENERAL NOTES:

1. ALL DIMENSIONS ARE IN INCHES [MM]
- *2. DIMENSIONS SHOWN ARE FOR RECOMMENDED ADULT HEIGHT. ADJUST VERTICAL DIMENSIONS AS NECESSARY TO COMPLY WITH FEDERAL, STATE, & LOCAL CODES
3. WATER LINE FROM CHILLER TO FOUNTAIN SHOULD BE COVERED WITH SPONGE FOAM RUBBER OR ICE WATER TYPE INSULATION OF ADEQUATE THICKNESS

NOTES: Dimensions shown for Adult ADA compliant installation. For Child ADA compliant parallel approach installation, decrease height of installation by 3 inches. Provide clear floor space as required. Adjust vertical dimensions as required to comply with federal, state, and local codes.

PRIOR TO INSTALLATION:

Important: Some options may slightly alter installation. To ensure proper installation review the manual thoroughly and verify rough-ins before beginning any work. File this manual with the owner or maintenance personnel upon completion of installation.

- Fixture mounting requirements: industry standard wall construction, adequate to support the fixture and installer provided wall anchors sufficient to secure the fixture.
- Receptacle(s) must be wired to a GFCI protected circuit. Fixture must be earth grounded per NEC (National Electrical Code).
- Inspect fixture and all parts from damages and all parts are bolted on.

IMPORTANT:

1. Water supply Service Angle Stop Valve and 2" x 4" Electrical GFCI Plug-In Receptacle to be supplied by others in accordance with local codes.
2. Provide 4" minimum clear space on fixture sides to allow for proper ventilation through cabinet louvers.
3. Water supply inlet is 3/8" outer diameter copper tube. Waste is 1-1/4" outer diameter.
4. Completely flush supply lines of all foreign debris before connecting to fixture. Water cooler is designed to not cause problems with taste, odor, color, or sediment. Optional water filter (WF1), is available should any of these problems arise from the water supply.
5. **DO NOT** solder tubes inserted into the coupler as damage to the o-ring may result.
6. All burrs must be removed from outside of cut tubes before inserting into strainer or other components.
7. Power supply must be identical in voltage, cycle and phase to that specified on the chiller data plate. Electrical outlet and furnished power cord with plug must be used to supply power to fixture. **DO NOT** wire compressor directly to the power supply.
8. This unit must be grounded per the requirements of applicable electrical codes.
9. **WARNING:** Warranty is voided if installation is not made following current Acorn Engineering installation instructions and if components are assembled to the fixture that are not approved by Acorn Engineering.
10. Fixture operates within water pressure range of 20-105 psig. Acorn Engineering will not warranty fixtures damaged when connected to supply lines with flow pressure lower than 20 psig or higher than 105 psig. A pressure regulator must be furnished by others on supply line if inlet pressure is greater than 105 psig.
11. Due to cold waste water, Acorn Engineering recommends that p-trap be insulated to prevent excessive condensation.
12. *Per UPC 609.10-All building water supply systems in which quick acting valves are installed shall be provided with devices to absorb the hammer caused by high pressure resulting from the quick closing of the valve. These pressure-absorbing devices shall be approved mechanical devices. Water pressure-absorbing devices shall be installed as close as possible to the quick closing valve.*

CLEANING & MAINTENANCE GUIDE:

1. Motors have lifetime lubrication and do not require scheduled maintenance.
2. Excess dirt or poor ventilation will cause the compressor overload protector to turn the compressor off and it will cycle on and off with no cold water coming out of bubbler. Periodically clean with vacuum cleaner, air hose or brush the condenser fins and cabinet ventilation louvers. In environments where dirt and dust is more prevalent, clean more frequently.
3. Periodically remove fountain top and clean out "Y" strainer.
4. **DO NOT** use harsh chemicals, abrasive or petroleum based cleaners. Use of these will void the Acorn Engineering warranty.
5. Exterior panels can be cleaned using mild household detergents or warm, soapy water. Extra care must be used cleaning chrome plated items and mirror finished stainless steel. They can scratch easily and should only be cleaned using a clean, soft cloth and mild soap with water or a mild glass cleaner.

NOTES:

- 1- STANDARD BI-LEVEL INSTALLATION IS SHOWN. FOR REVERSE BI-LEVEL MF9 MOUNTING FRAME AND TOP TRIM PANEL ARE OPPOSITE TO THAT SHOWN.
- 2- CHILLER INSTALLATION IS ALWAYS ON THE RIGHT HAND SIDE OF THE SHELF.

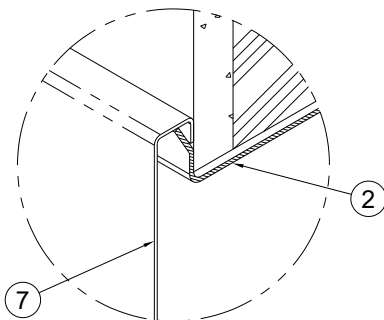

ENGAGEMENT DETAIL

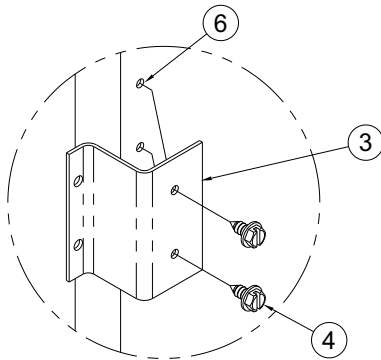

ANCHORING CLIP DETAIL

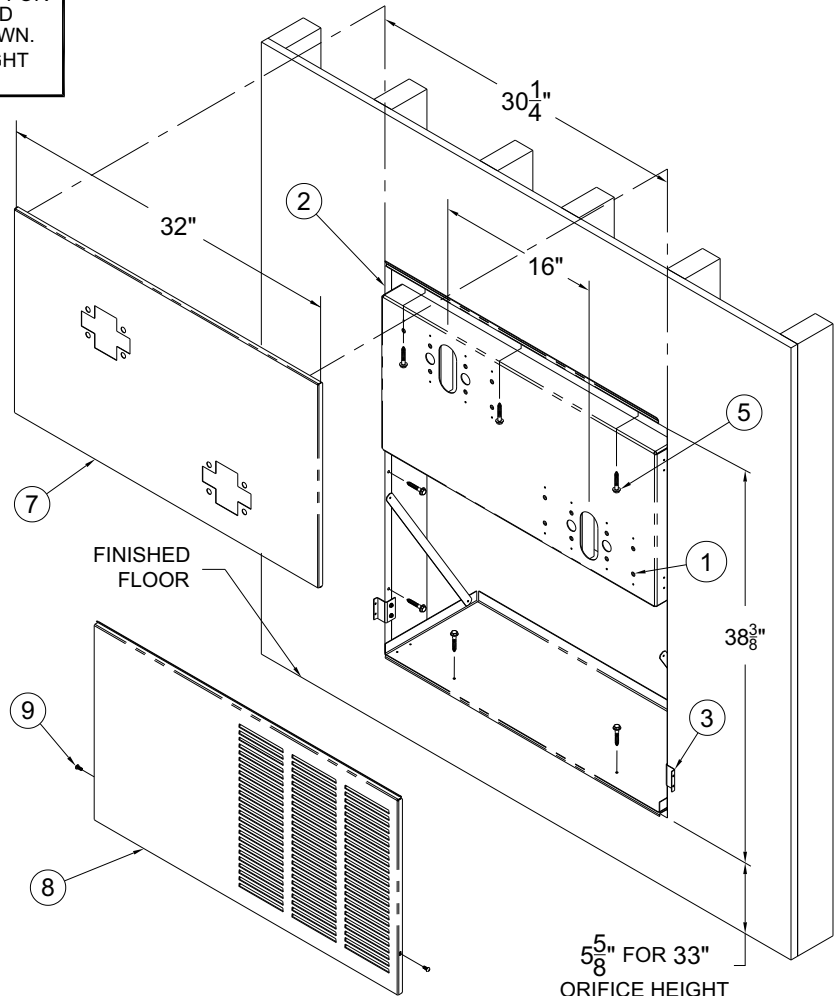

INSTALLATION INSTRUCTIONS:

- A- PROVIDE 30-1/4" WIDE x 38-3/8" TALL WALL OPENING AT APPROPRIATE HEIGHT. PROVIDE STRUCTURAL SUPPORT AROUND INSIDE OF THE OPENING FOR FRAME ANCHORING.
- B- CAREFULLY REMOVE FRAME (2), PANEL ANCHORING CLIPS (3) AND SCREWS (4) FROM PACKAGING PREVENTING DAMAGE.
- C- CENTER FRAME (2) WITHIN WALL OPENING WITH SIDE, TOP AND BOTTOM LIPS OVERLAPPING OUTSIDE THE OPENING UP AGAINST FINISHED WALL FACE. SET CHILLER SHELF IN PLACE ALIGNING ANCHORING HOLES WITH HOLES IN FRAME BOTTOM. SECURE TO WALL THROUGH THE SIDES, TOP AND BOTTOM USING HARDWARE (5) BY OTHERS ENSURING 16" CENTERLINE DIMENSION LEFT-TO-RIGHT.
- D- INSTALL TWO ANCHORING CLIPS (3) AT BOTTOM ON OUTER SIDES OF FRAME (2) ALIGN HOLES IN CLIPS WITH HOLES (6) IN FRAME AND USE SHEETMETAL SCREWS (4) PROVIDED. SEE ANCHORING CLIP DETAIL.
- E- WHEN THEY ARRIVE, CAREFULLY REMOVE THE TRIM PANEL (7) AND LOUVERED PANEL (8) WITH SCREWS (9) FROM THE PACKAGING PREVENTING SCRATCHING AND DAMAGE.
- F- TRIM PANEL (7) INSTALLS BY ENGAGING OVER TOP JOGGLED OUT FRAME (2) FLANGE AS SHOWN IN ENGAGEMENT DETAIL.
- G- ASSEMBLY OF DRINKING FOUNTAINS THROUGH TRIM PANEL (7) INTO MOUNTING POINTS (1) HELPS SECURE PANEL.
- H- LOUVERED PANEL (8) INSTALLS AFTER CHILLER & FOUNTAIN INSTALLATION IS COMPLETED. TOP OF LOUVERED PANEL (8) SLIPS UNDERNEATH TRIM PANEL (7). ENGAGE SCREWS (9) INTO ANCHORING CLIPS (3) THROUGH LOUVERED PANEL (8) & TRIM PANEL (7) TO SECURE.

START UP:

1. Before connecting power supply, but after thoroughly flushing the supply line and connecting it to the cooler, turn on building water supply and check all connections for leaks.
2. Air within the drinking fountain system or the structure supply piping will cause an irregular bubbler outlet stream until purged out by incoming water. Covering the bubbler with a clean cup (or similar object) is recommended when first activating drinking fountain to prevent excessive splashing. Depress the pushbutton until steady water stream is achieved.
3. If water flow requires adjustment, insert a slotted narrow blade screwdriver in the hole centered on the underside of the fixture in the knee clearance area up to the flow regulator. Turning clockwise will increase flow and turning counterclockwise will decrease flow.
4. Recheck all water connections with water flowing through system.
5. With power still NOT connected, carefully manually rotate cooling fan to ensure proper clearance and free fan action.
6. Provide power to water chiller and make sure unit begins to function.
7. Assemble louvered bottom trim panel with screws provided to brackets on either side of wall mounting frame.

TROUBLE SHOOTING:

IMPORTANT: BEFORE MAKING ANY OF THE REPAIRS LISTED, MAKE SURE THE WATER CHILLER IS DISCONNECTED FROM THE ELECTRICAL SUPPLY AND THE WATER SUPPLY VALVE IS SHUT OFF.

1. Adjustments:

Cartridge – The water flow can be adjusted using a slotted narrow blade screwdriver and turning clockwise to increase flow and counterclockwise to decrease flow.

Cold Water Thermostat – The water temperature can be adjusted using a slotted screwdriver and turning clockwise to make colder and counterclockwise to make warmer.

Bubbler Stream - Bubbler can be rotated slightly to direct the stream backwards or forwards. Adjust the stream to minimize splashing. Splashing may occur from bubbler stream if the unit is not level. Shim lower mounting point, if necessary, to level chiller.

2. Compressor Does Not Run:

- a. Check the electrical supply for power and correct voltage. The incoming voltage must be within 10% of the rated voltage on the serial nameplate.
- b. If the cold thermostat capillary bulb loses its charge or becomes kinked it will fail in the open position causing a disruption of power to the compressor. Disconnect electrical supply to the water chiller and using an ohm meter check for continuity across the two electrical terminals on the thermostat. Install a new thermostat if there is no continuity.
- c. Check for loose wires within the compressor box. The incoming power leads must be connected to the overload and relay.
- d. If all components check positive for continuity then test the wiring harness plug for continuity to see if there is a broken wire within the wiring harness insulation.

3. Compressor Runs – Water Is Warm:

- a. The most common cause for a water chiller to run without producing cold water is a loss of refrigerant. The water chiller must be taken to a certified refrigerant technician for repairs.
- b. Make sure the condenser fan motor is operative. The fan blade must turn freely to help remove the heat of compression.
- c. An incorrect refrigerant charge, restriction or defective compressor (not pumping) will also cause the compressor to run without producing cold water. All these signs indicate a problem within the refrigeration system and the water chiller must be checked by an authorized service company.

4. Compressor Cycling On Overload Protector:

- a. A dirty condenser or a blocked fan will cause a high head pressure and frequent cycling of the overload protector.
- b. Check the incoming voltage to make sure it is within 10% of the serial nameplate rating.
- c. A restriction or moisture in the system will also cause intermittent cycling. A certified refrigeration mechanic should be contacted in this situation.
- d. Change the overload or relay if defective.

5. Noisy Operation:

- a. Check to make sure the fan blade is rotating freely.
- b. Check the compressor mounting to make sure the pins and clips are not rattling. If the compressor appears to be noisy internally, it must be replaced.

6. Restricted Or No Water Flow:

- a. Ensure water supply service stop valve is fully open.
- b. Verify minimum 20 psig supply line flow pressure.
- c. Check for twists or kinks in outlet tubing.
- d. Check the water inlet strainer. Sediment from the main supply can get trapped in the screen along with installation materials such as pipe dope and flux. The screen should be cleaned and checked on a regular basis and replace if needed.

NOTE: STRAINER SCREEN MUST BE IN PLACE FOR WATER TO FLOW.

- e. The cartridge valve located in the water control assembly or bubbler can also become clogged with foreign material. The cartridge valve can only be replaced and not repaired.
- f. Check flow adjustment. See start up note #3.
- g. The water chiller may also develop a freezing condition in which the water will become frozen inside the evaporator coil. This indicates a refrigeration problem or thermostat failure in which case the water chiller needs to be checked by a qualified technician.
- h. No power to transformer connections, loose or wires cut.

7. Water Drips Or Will Not Shut Off:

- a. Open fixture. Loosen nuts holding valve bracket assembly to bottom of fixture but do not remove. Move complete valve bracket assembly further back from the front push pad and tighten to lock in place.
- b. Replace valve cartridge.

8. If Light Within Sensor Does Not Flash When User Is Within Range:
 - a. Verify transformer input and output voltages: 120VAC input & 9VDC output
 - b. Replace defective transformer..
 - c. Transformer polarity crossed. Replace transformer, sensor may be damaged and also need replacement.
 - d. Sensor in “Security Mode” after 30 seconds of constant detection. Remove source of detection and wait 30 seconds before checking.
 - e. Sensor is picking up a highly reflective surface. Eliminate cause of reflection and wait 30 seconds before checking.
 - f. Replace sensor.
9. If Light Within Sensor Lens Flashes Once When Use Is Within Range:
 - a. Repair bad connection from sensor to solenoid.
 - b. There is debris or scale in the solenoid assembly. Remove solenoid, pull out plunger and spring. Clean with scale remover solution.
 - c. There is debris or scale in the center or two holes in convolution of the water diaphragm. Remove and clean.

CARTRIDGE REPLACEMENT/ STRAINER MAINTENANCE

Note: Use the Universal Maintenance Tool to perform the following:

1. Strainer Plug **must** be removed before Cartridge replacement and Strainer maintenance (no need to turn the water off at the Angle Stop). Some residual water will drain during Plug removal.
2. Clean Strainer as needed using clean water.
3. Cartridge Replacement - insert diamond end of the Universal Tool into Pushbutton, rotate 90 degrees and pull firmly to remove the Button. Remove Cartridge Retaining Nut . Remove and replace Cartridge. When replacing Cartridge, be sure to align the inlet and outlet Ports on the Cartridge with the Ports in the Valve Body.

• **NOTE: STRAINER SCREEN MUST BE IN PLACE FOR WATER TO FLOW.**

CARTRIDGE VALVE PARTS BREAKDOWN

ITEM #	PART NUMBER	DESCRIPTION
1	7003-095-000	Valve Body Sub Assembly
2	7000-060-000	Valve Cartridge
3	7000-052-000	Retaining Nut
4	7003-864-000	Strainer, Auto Stop
5	7003-097-001	Strainer Cap
6	7003-194-199	Maintenance Tool

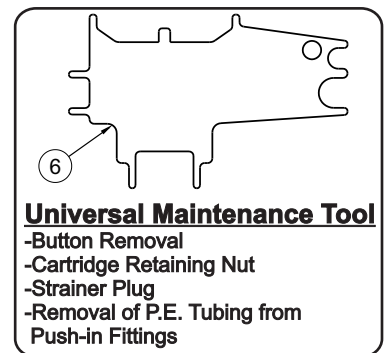
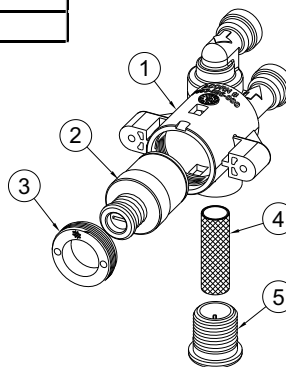

PUSH-IN FITTING INSTALLATION

NOTE: FITTINGS AND TUBE SHOULD BE KEPT CLEAN, BAGGED AND UNDAMAGED PRIOR TO INSTALLATION.

TO CUT TUBE:

Cut to fit length of 1/4" PE tubing and remove any burrs or sharp edges. Ensure that the outside diameter is free from score marks. Tube ends should be square.

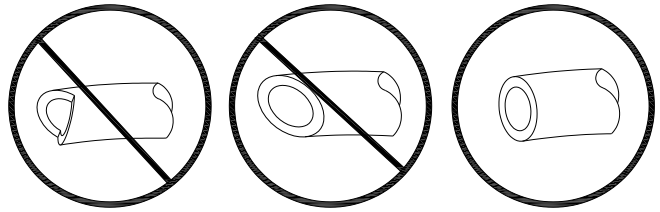

INSERTING THE TUBE:

1. Firmly and fully insert the tubing end into the push-in fitting up to the tube stop located approximately 1/2" deep.

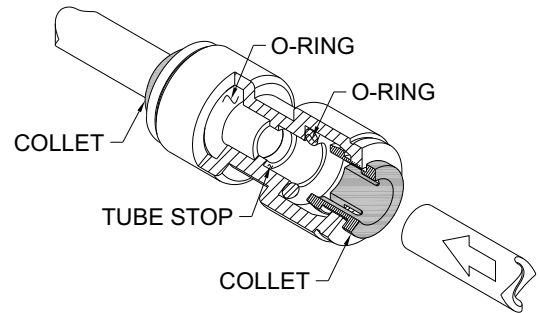

2. Pull on the fitted tubing to ensure it is secure. Tube should not come free from the fitting. Water test the connection assembly prior to leaving the site to ensure there are no leaks.

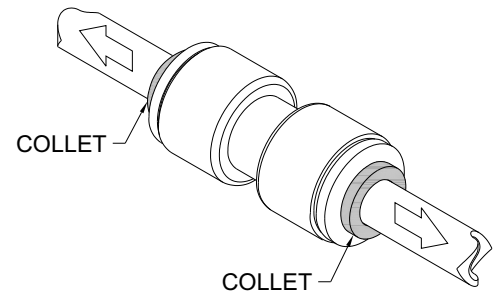

DISCONNECTING THE TUBE:

To disconnect the tube from the fitting ensure that the water line is depressurized. Push collet square towards the push-in fitting body and hold. While holding the collet in, pull on the PE tubing to remove from the push-in fitting.

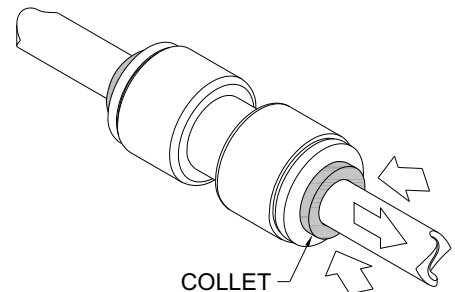

VANDAL RESISTANT DRINKING FOUNTAIN PARTS BREAKDOWN DRAWING
Shown is the 18" long unit, however the parts are the same for the 14" long unit.

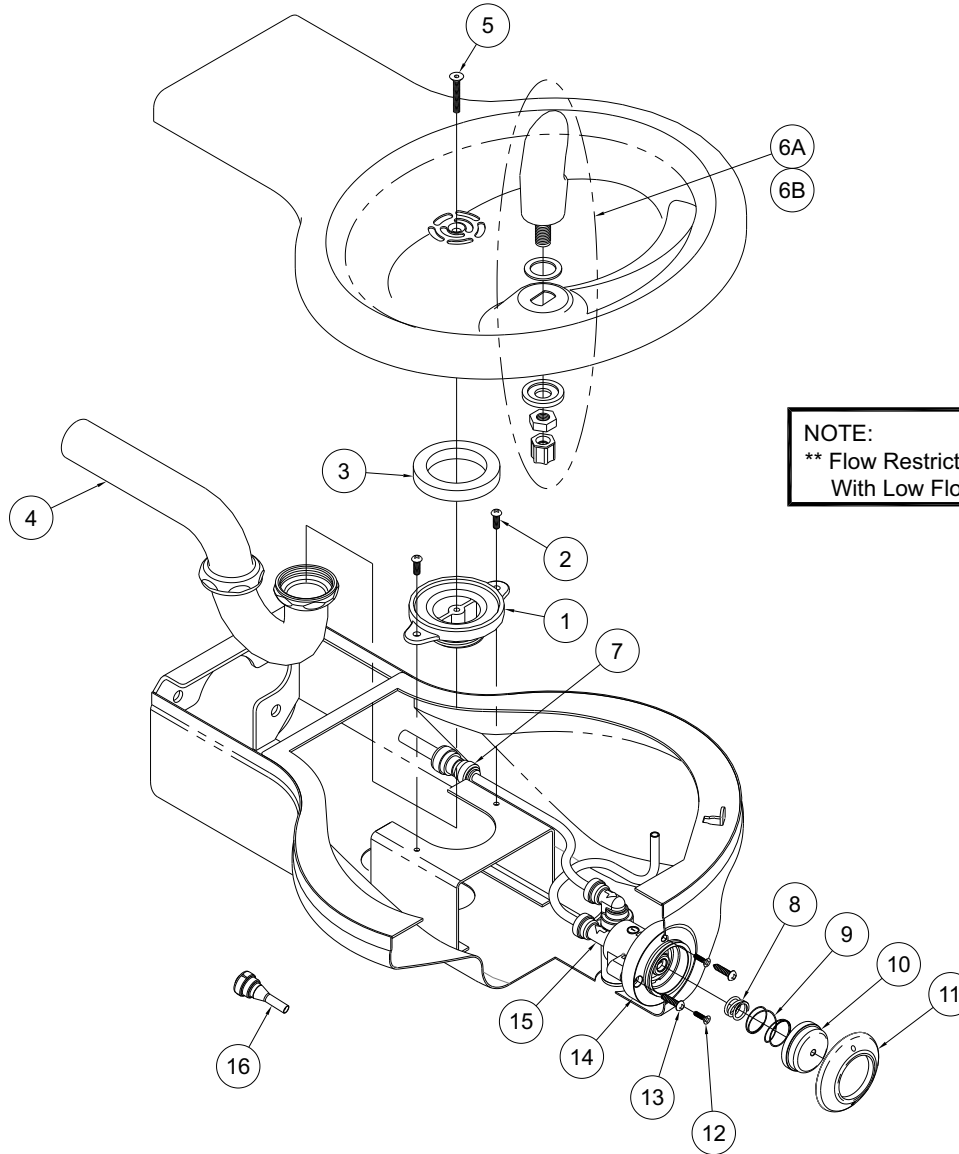

NOTE:
** Flow Restrictor Only Available
With Low Flow Bubbler.

ITEM #	PART NUMBER	DESCRIPTION	ITEM #	PART NUMBER	DESCRIPTION
1	7000-005-199	Drain Adapter	9	7003-193-000	Spring, Pushbutton Return
2	0116-016-000	#10-32 x 3/8" Phillips Truss Head Screw	10	7003-196-199	Pushbutton, Chrome
3	7000-006-000	Flat Drain Adapter Gasket	11	7003-197-199	Escutcheon, Chrome
4	7000-015-000	1-1/4" OD P-Trap	12	0161-062-000	#6-32 x 1/2" Phillips, Flat Head Screw
5	0152-010-000	#10-32 x 1" Hex Flat Head Screw	13	0124-055-000	#8 x 3/4" Phillips, Round Head Screw
6A	7000-012-001	Stainless Steel Bubbler Assembly	14	7003-198-199	Mounting Sleeve
6B	7000-099-002	Flexible Gray Bubbler Assembly	15	7003-095-001	Valve Body Sub Assembly
7	1895-123-000	1/4" x 3/8" OD Tube Union Push-In	16	7003-093-001	Flow Restrictor - Low-Flow Bubbler Only
8	7003-195-000	Spring, Overtravel			

Repairs must be made with Murdock Manufacturing parts only. Please order through your local representative or distributor. The phone number to locate your local representative is 1.800.591.9360.