

SPECIFICATION:

JOSAM 32100-TG SERIES COATED CAST IRON FLOOR DRAIN, TWO-PIECE BODY WITH DOUBLE DRAINAGE FLANGE, WEEPHOLES, WEJLOC®NON-PUNCTURING FLASHING COLLAR, BOTTOM OUTLET, ROUND TOP WITH HEAVY-DUTY, LOOSE-SET TRACTOR GRATE AND CAST IRON 6" STANDARD EXTENSION.

FLOOR DRAIN
9" ROUND TOP, TRACTOR GRATE

SERIES **32100-TG-44**

SLOT WIDTH - 3/8" (MEETS ADA)
FREE AREA - 15.7 IN²

FORMERLY 36000 SERIES

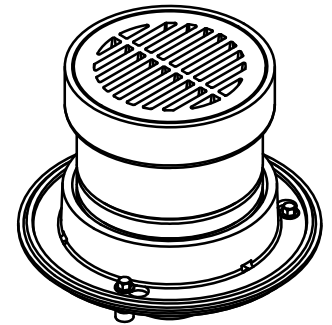
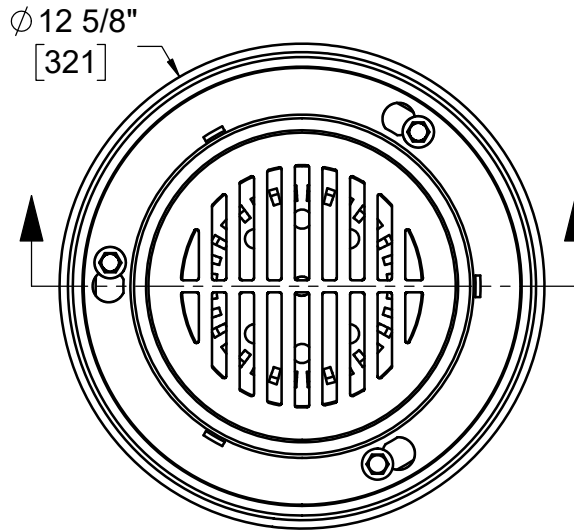

*ADD 1/4" WHEN FURNISHED WITH NIKALOY OR BRONZE TOP (-1 OR -2)

◆ GASKET CONFORMS WITH ASTM-C564

PIPE SIZE
2"
3"
4"

OUTLET TYPE
-T THREADED
-X INSIDE CAULK
-Y HUB WITH GASKET
-Z NO-HUB

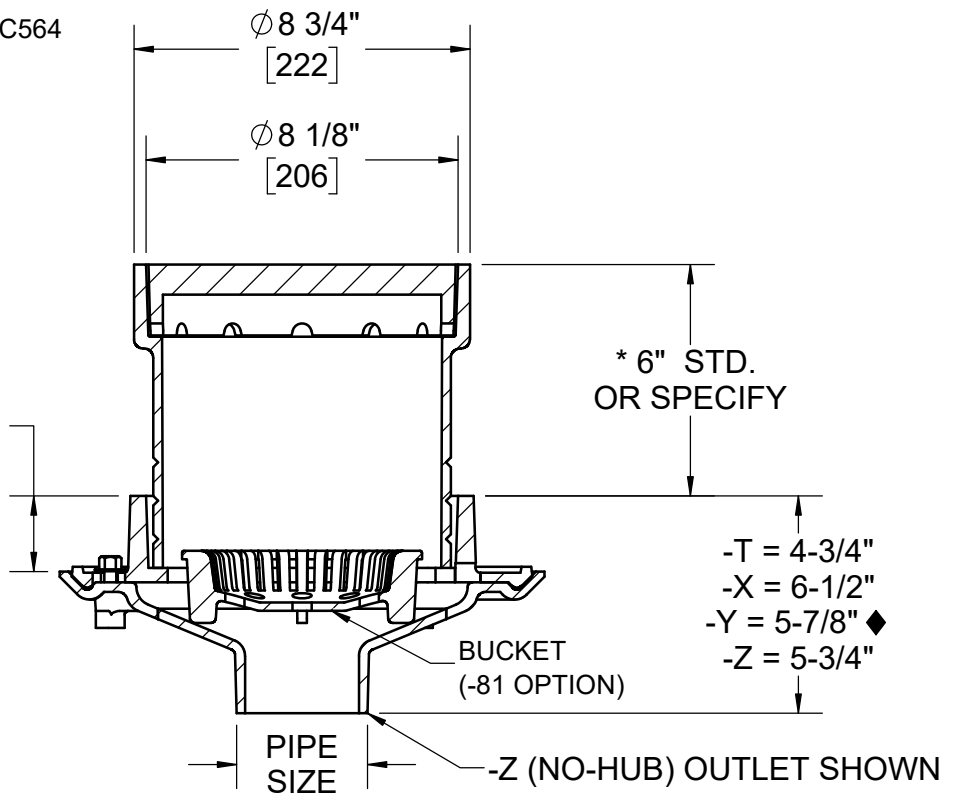

X	-TG	TRACTOR GRATE			-49	3/4" PRIMER TAP
	-1	SATIN FINISH NIKALOY TOP			-50	1/2" PRIMER TAP
	-2	SATIN FINISH BRONZE TOP			-66	NO-HUB SIDE OUTLET
	-7	DUCTILE IRON GRATE			-81	SLOTTED CAST IRON BUCKET (069447)
	-15	CHAINED GRATE			-84	STAINLESS ST. MESH BUCKET LINER
	-VP	SECURED GRATE, VANDAL-PROOF SCREWS			-88	SUPPLEMENTARY STRAINER
	-ARE	ACID-RESISTING EPOXY			-92	GALVANIZED CAST IRON PARTS
X	-44	FIXED EXTENSION, CAST IRON (6" STD. OR SPECIFY HEIGHT)				
	-44-92	FIXED EXTENSION, GALVANIZED (6" STD. OR SPECIFY HEIGHT)				

DATE OF LAST CHANGE: 07/23/18

DIMENSIONS ARE SUBJECT TO MANUFACTURERS TOLERANCES AND CHANGE WITHOUT NOTICE. WE CAN ASSUME NO RESPONSIBILITY FOR USE OF SUPERSEDED OR VOID DATA.



MICHIGAN CITY, INDIANA

NOTES

WARNING: Cancer and Reproductive Harm - www.P65Warnings.ca.gov