

## Neo™ Double Paper Holder

**FEATURES:**

- Double Paper Holder measures 11-11/16" wide
- Metal construction
- Corrosion resistant finishes
- Mounting hardware is included
- Coordinates with Neo Collection

**STOCK FINISHES:**

PC BN

**SPECIALTY FINISHES:**

BBZ MB ORB PB PN

**WARRANTY:**

Visit [www.speakman.com](http://www.speakman.com) for full product warranty information

- Limited Lifetime Warranty (consumer)
- 1 Year Limited Warranty (commercial)

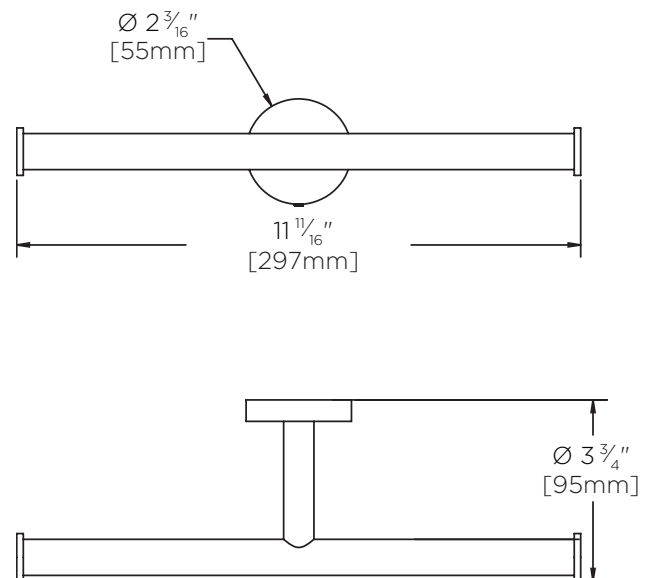

All dimensions are in inches (millimeters) unless otherwise specified and are subject to change without notice.

Architect/Engineer Approval Space:

P: 800-537-2107  
 F: 800-977-2747  
 W: WWW.SPEAKMAN.COM  
 R: 02-NOVEMBER 2019