

SPECIFICATION:

JOSAM 17590-DP SERIES WALL-MOUNTED, SINGLE LAVATORY CARRIER CARRIER WITH HANGER PLATES AND ADJUSTABLE SUPPORTING RODS.

**LAVATORY CARRIER
WALL-MOUNT HANGER PLATE**

SERIES **17590-DP**

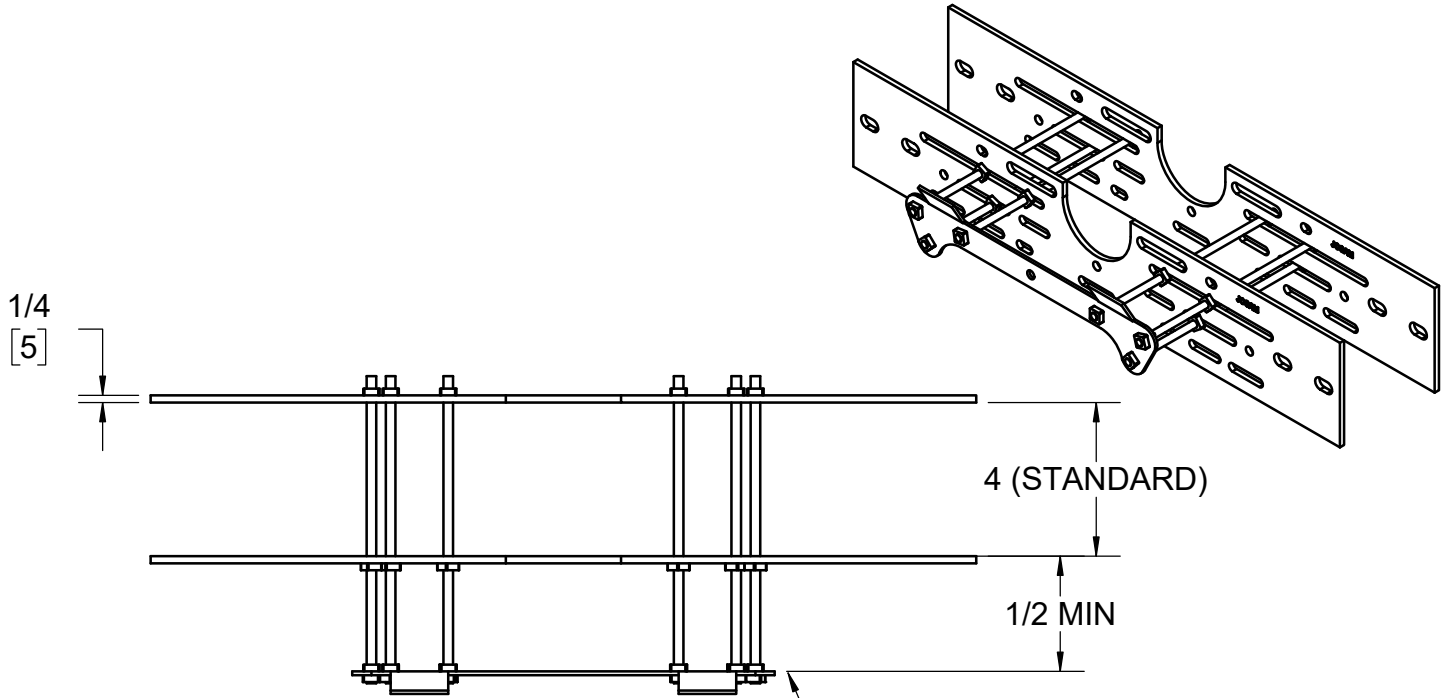

HANGER(S) FURNISHED WITH FIXTURE

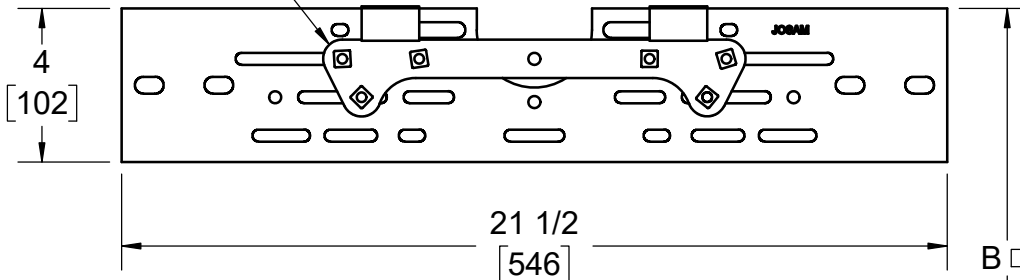

□ VARIABLE - DEPENDS ON FIXTURE EXCEPT WHEN STANDARD PLATE IS FURNISHED C = 18-1/4"

FINISHED FLOOR

MANUFACTURER

NUMBER

SIZE

NAME

DIMENSIONS

B _____

RIM HEIGHT BASED ON "B" DIM SHOWN

X	-DP	DOUBLE PLATE CARRIER
	-10	STUDS FOR WALLS OVER 7" (SPECIFY WALL THICKNESS)

WARNING: Cancer and Reproductive Harm - www.P65Warnings.ca.gov

DATE OF LAST CHANGE: 05/31/18

DIMENSIONS ARE SUBJECT TO MANUFACTURERS TOLERANCES AND CHANGE WITHOUT NOTICE. WE CAN ASSUME NO RESPONSIBILITY FOR USE OF SUPERSEDED OR VOID DATA.

JOSAM

MICHIGAN CITY, INDIANA

NOTES