

BACK ACCESS PANEL

BASE ROUGH-IN VIEW

INSTALLATION INSTRUCTIONS:

- A- PROVIDE 30" SQUARE MINIMUM x 6" DEEP MINIMUM CONCRETE SLAB BY OTHERS TO SECURELY ANCHOR FIXTURE. INSTALL THE FOUR PROVIDED CONCRETE ANCHORS (1) AT DIMENSIONS SHOWN TO MATCH HOLES (2) IN FIXTURE BASE.
- B- ROUGH-IN WASTE OUTLET (3) AT DIMENSION SHOWN FOR 1-1/4" PVC PIPE SIZE OR USE THE COMPRESSION ADAPTER PROVIDED LOOSE FOR 1-1/4" OUTER DIAMETER TUBE.
- C- ROUGH-IN WATER SUPPLY (4) WITHIN THE BOTTOM OPENING FOR CONNECTION TO VALVE USING SUPPLIED 6" LONG FLEX HOSE WITH 1/2" NPS FEMALE END WHICH WILL ACCOMODATE 1/2" NPT MALE ADAPTER.
- D- CAREFULLY REMOVE THE FIXTURE AND COMPONENTS FROM THE PACKAGING PREVENTING SCRATCHING AND DAMAGE.
- E- REMOVE BACK ACCESS PANEL (5) FROM FIXTURE PEDESTAL (6) & BOTTOM ACCESS PANEL (7) FROM CANTILEVER (8). ENSURE PUSHBUTTONS (9), WASTE PIPING (10), AND BUBBLERS (11) ARE SECURE AND CHECK ALL THE TUBING CONNECTIONS TO MAKE SURE THEY DID NOT COME LOOSE IN SHIPMENT.

- F- SET PEDESTAL (6) IN PLACE ALIGNING BASE HOLES (2) WITH THE INSTALLED ANCHORS (1) AND SECURE WITH THE 1/2" UNC HARDWARE (12) PROVIDED.
- G- ASSEMBLE CANTILEVERS (8) TO PEDESTAL (6) USING THE HARDWARE (13) PROVIDED PASSING THE BUBBLER & BUTTON TUBING, AND PIPING (10) THRU PEDESTAL (6) OPENING.
- H- MAKE-UP WASTE CONNECTION TO THE WASTE PIPING (10).
- I- INSTALL AIR-CONTROL VALVE WITHIN PEDESTAL USING THE HARDWARE PROVIDED. CONNECT 1/4" O.D. TUBING COMING FROM 1/4 TURN VALVES AND 1/8" O.D. TUBING FROM PUSH-BUTTONS TO VALVE. NOTE: ONLY HANDTIGHTEN FERRULE NUTS.
- J- FLUSH WATER SUPPLY (4) BY OTHERS OF ALL DEBRIS PRIOR TO CONNECTING TO VALVE.
- K- CONNECT WATER SUPPLY (4) BY OTHERS TO VALVE USING SUPPLIED 1/2" NPS FLEX HOSE.
- L- TEST OPERATION OF BUBBLERS BY DEPRESSING BUTTONS (9). ADJUST FLOW RATE AS REQUIRED USING IN-LINE 1/4 TURN VALVES. CHECK ALL CONNECTIONS AND WASTE PIPING FOR LEAKS. CORRECT IF PRESENT.
- M- RE-INSTALL BACK ACCESS PANEL (5) AND BOTTOM ACCESS PANEL (7).

 <p>MURDOCK-SUPER SECUR P.O. Box 3527 Industry, CA 91744 15125 Proctor Ave Industry, CA 91746 Phone: (800) 591-9880 www.murdock-supersecur.com</p>	TITLE	
	<p>SQUARE OUTDOOR STONE PEDESTAL BI-LEVEL DRINKING FOUNTAIN</p>	
MANUFACTURE DATE	DATE ISSUED	DRAWING NUMBER
<p>OCTOBER 2005 TO PRESENT</p>	<p>09/27/05</p>	<p>9938-225-001</p>
	DATE REVISED	
	<p>04/01/16</p>	

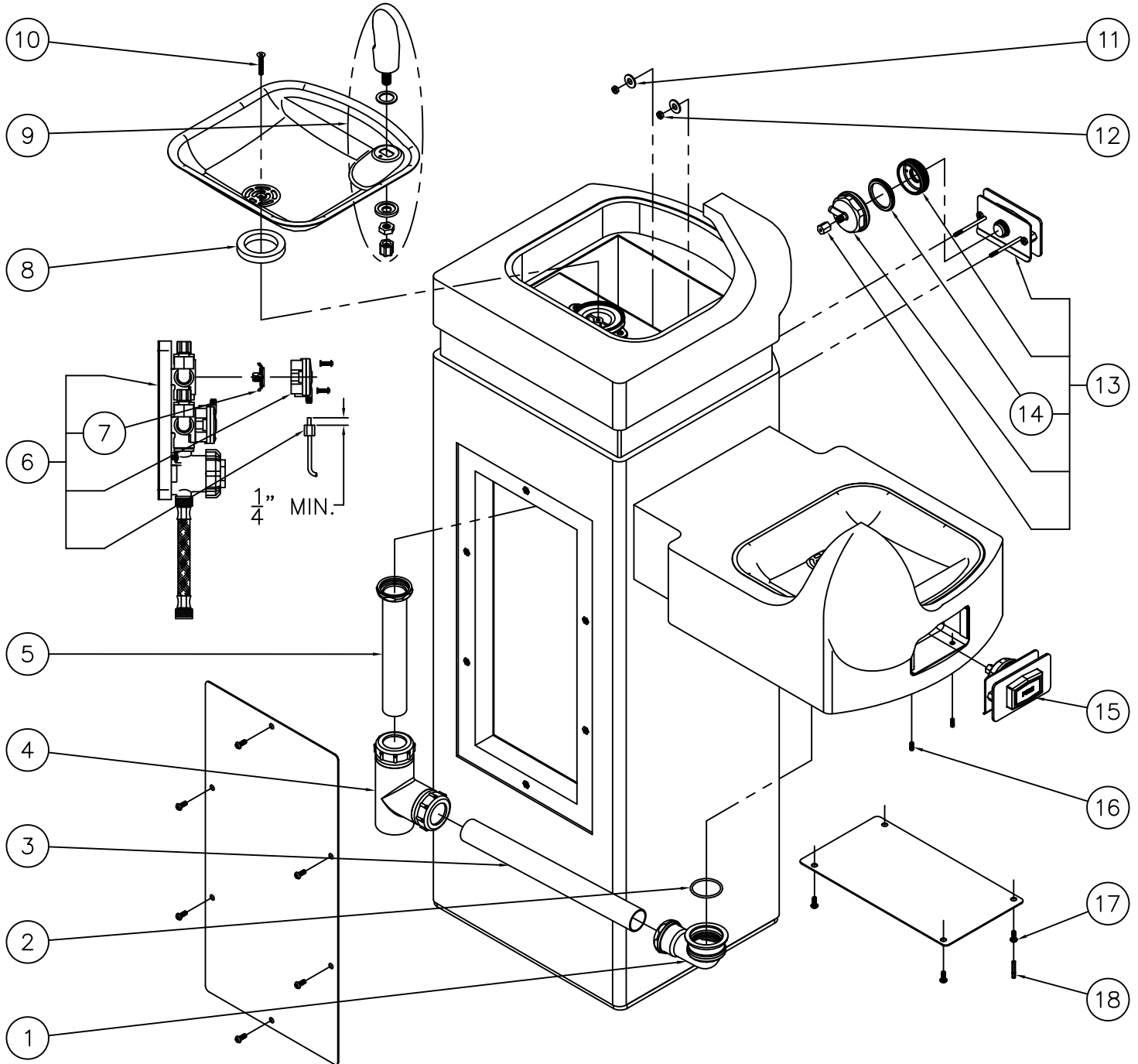

1	7000-017-001	ELBOW ASSEMBLY	10	0152-010-000	CENTER REJECT ALLEN FLAT HEAD SCREW
2	0401-128-000	O-RING	11	0331-006-000	STAINLESS STEEL WASHER
3	7000-111-199	1-1/4" O.D. x 14" LONG DRAIN TUBE	12	0302-003-000	8/32" UNF STAINLESS STEEL HEX NUT
4	7002-011-001	BI-LEVEL ADULT ADA TEE ASSEMBLY	13	7031-160-001	STONE FOUNTAIN PUSHBUTTON ASSEMBLY
5	7000-019-001	1-1/4" OUTER DIAMETER TAILPIECE	14	2566-001-000	PUSHBUTTON DIAPHRAGM
6	2590-010-001	S/T NON-METERING AIR-CONTROL VALVE	15	6154-035-002	STONE CANTILEVER PUSHBUTTON ASSEMBLY
7	2563-010-001	WATER DIAPHRAGM ASSEMBLY	16	0186-008-000	10-32 x 3/8" LONG SET SCREW
8	7000-006-000	FLAT DRAIN ADAPTER GASKET	17	0112-002-000	CENTER REJECT ALLEN BUTTON HD SCREW
9	7000-012-001	STAINLES STEEL BUBBLER	18	0296-025-199	CENTER REJECT HEX DRIVER BIT
ITEM	PART NUMBER	DESCRIPTION	ITEM	PART NUMBER	DESCRIPTION



MURDOCK-SUPER SECUR
P.O. Box 3527 Industry, CA 91744
15125 Proctor Ave Industry, CA 91746
Phone: (800) 591-9880
www.murdock-supersecur.com

TITLE

SQUARE OUTDOOR STONE PEDESTAL BI-LEVEL DRINKING FOUNTAIN

MANUFACTURE DATE

**JANUARY 2006
TO PRESENT**

DATE ISSUED

05/08/07

DATE REVISED

04/04/16

DRAWING NUMBER







9938-225-500

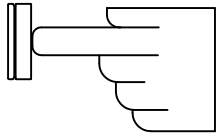

PUSH PAD / PUSH BUTTON FRU FREEZE RESISTANT DRINKING FOUNTAINS
NON-METERING AIR-CONTROLLED VALVE - (DIRECT ACTING)

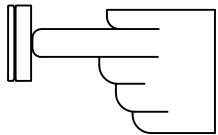
CONDITION:

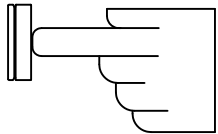
SOLUTION:

<p>NO WATER FLOW:</p>  	<ol style="list-style-type: none"> 1.1 Check water main supply – open. 1.2 Inspect checkstops – open. 1.3 Inspect checkstop strainer for debris – clean. 1.4 Check 1/8” O.D. tubing and fittings for leaks. 1.5 Check pushbutton air diaphragm for holes. 1.6 Check servomotor diaphragm center hole for blockage.
<p>WATER DRIPS / WILL NOT SHUT OFF:</p> 	<ol style="list-style-type: none"> 2.1 Check servomotor diaphragm offset hole for debris. 2.2 Check servomotor seat for build-up or damage. 2.3 Check servomotor seat o-ring for damage. 2.4 Check servomotor plate and diaphragm for obstruction.
<p>REDUCED WATER FLOW:</p>  	<ol style="list-style-type: none"> 3.1 Check water main supply for 20 psig minimum flow pressure. 3.2 Check valve riser tubing for crimping. 3.3 Inspect checkstop strainer for debris – clean. 3.4 Check valve flow control for blockage – clean. 3.5 Inspect bubbler for debris – clean.
<p>PREMATURE WATER SHUTOFF:</p>  	<ol style="list-style-type: none"> 4.1 Check 1/8” O.D. tubing and fittings for leaks. 4.2 Check pushbutton air diaphragm for holes.

Refer to Air-Controlled Valve Maintenance Detail on drawing # 9940-203-001 for -FRA_ Above Ground units and on drawing # 9940-204-001 for Stone & -FRU_ Below Ground units to locate solutions above.

	<p>MURDOCK-SUPER SECUR P.O. Box 3527 Industry, CA 91744 15125 Proctor Ave Industry, CA 91746 Phone: (800) 591-9880 www.murdock-supersecur.com</p>	<p>FRU FREEZE RESISTANT FOUNTAIN VALVE MAINTENANCE INSTRUCTIONS</p>		
<p>TITLE JANUARY 2006 TO PRESENT</p>		<p>MANUFACTURE DATE 10/20/05</p>	<p>DATE ISSUED 03/15/16</p>	<p>DRAWING NUMBER 9940-202-001</p>



**PUSH PAD / PUSH BUTTON BELOW GROUND FREEZE RESISTANT DRINKING FOUNTAINS
NON-METERING AIR-CONTROLLED VALVE - (DIRECT ACTING)**

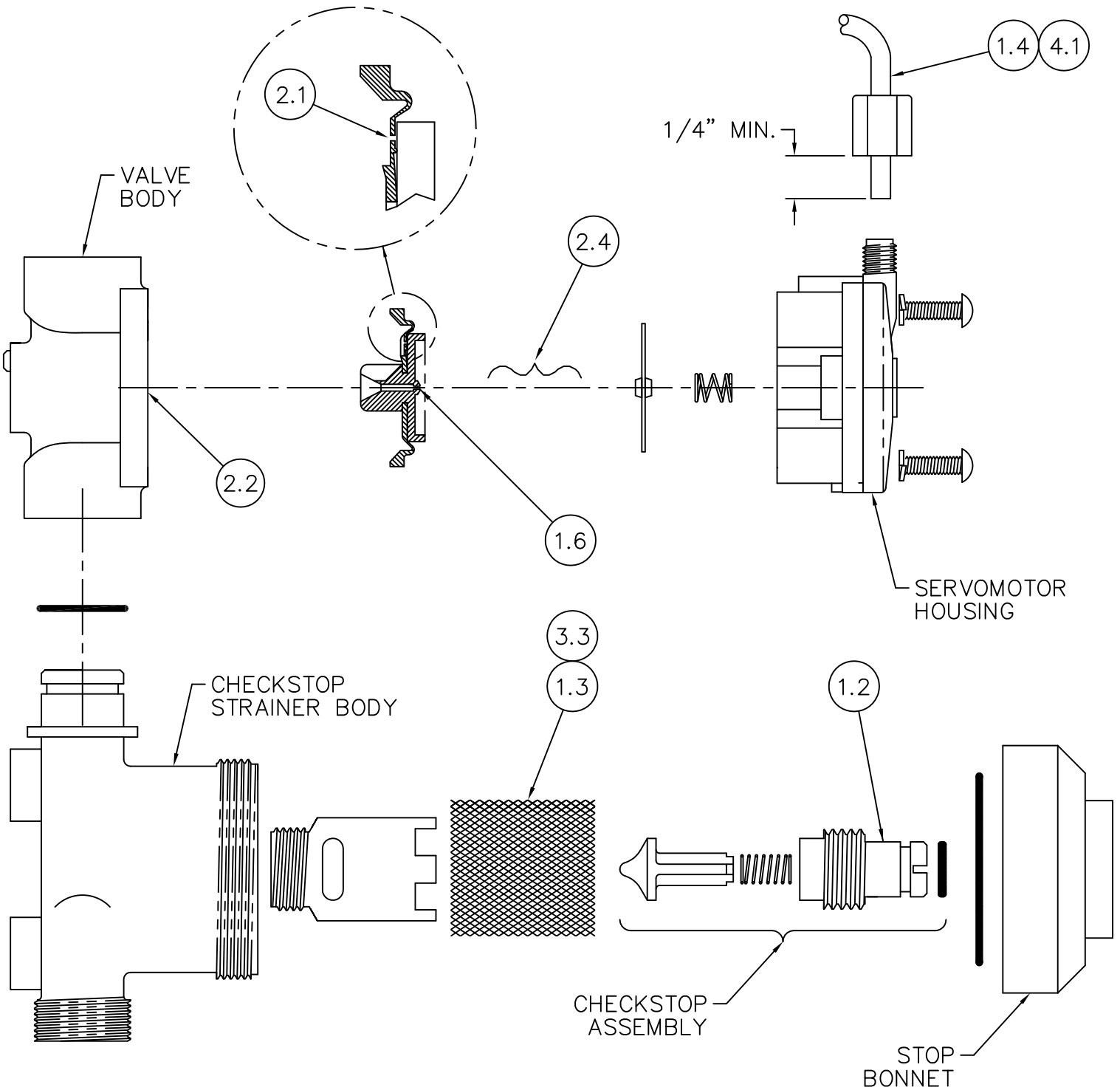

CHECKSTOP STRAINER - SERVOMOTOR DETAIL

Refer to drawing #9940-202-001 for Valve Maintenance Instructions numbered solutions detailed above.

<p>MURDOCK-SUPER SECUR P.O. Box 3527 Industry, CA 91744 15125 Proctor Ave Industry, CA 91746 Phone: (800) 591-9880 www.murdock-supersecur.com</p>	<p>TITLE NON-METERING FRU AIR-CONTROLLED VALVE MAINTENANCE INSTRUCTIONS</p>		
	<p>MANUFACTURE DATE JANUARY 2006 TO PRESENT</p>	<p>DATE ISSUED 12/07/05</p> <p>DATE REVISED 03/15/16</p>	<p>DRAWING NUMBER 9940-204-001</p>