

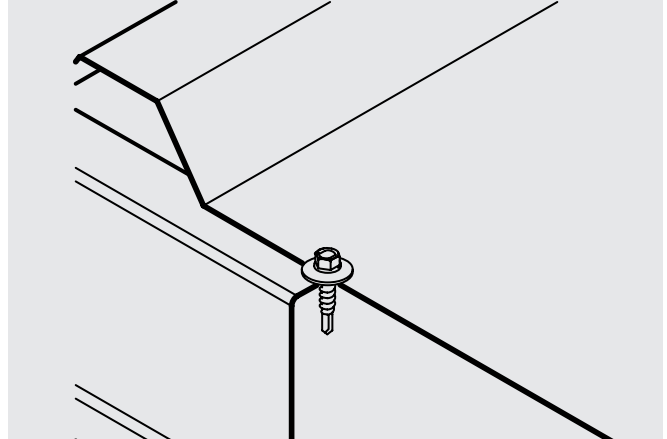

#8–18 Impax Utility SD2 Metal to Metal Fastener



Features and Benefits

- Precision cold forged point assuring superior strength and the fastest drilling time performance
- Designed to have low driving and thread engagement torque and provide maximum clamp load
- Available with no sealing washer or with bond seal washer

Application

Metal panel to light gauge metal application

Product Selection

Material No.	Fastener Length	Thread Length*	Description	Carton Wt. (lbs.)	Carton Qty.
1333752	1/2"	Full	SDU-#8x1/2-HW1/4-GB15/32	40	5,000
793121	3/4"	Full	SDU-#8x3/4-HW1/4-GB15/32	45	5,000

Plain product bulk carton packed, unless otherwise noted.

*Note – Thread length measured from end of pilot length to top of the threads.



#8–18 Impax Utility SD2 Metal to Metal Fastener

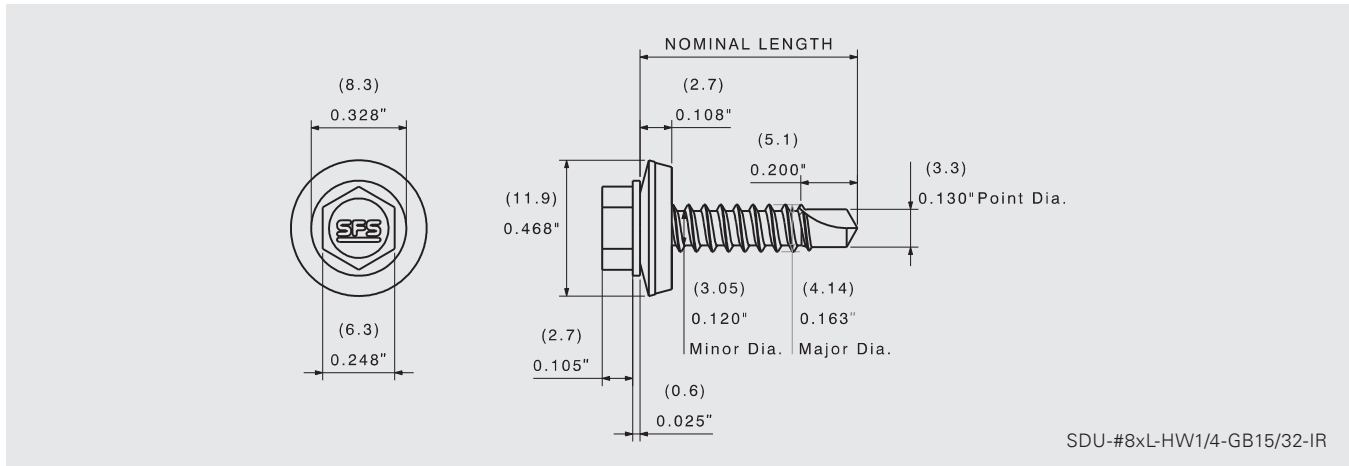

SDU-#8xL-HW1/4-GB15/32-IR

Product Specifications

Diameter:	#8 (4.4 mm)	Drill Point:	SD2
Threads Per Inch:	18	Drill Capacity:	0.035"–0.100" (0.899 mm–2.540 mm)
Head Style:	1/4" dia. HWH AF (6.3 mm)	Thread Major Dia:	0.163" (4.14 mm)
Washer:	15/32" galvanized and EPDM bond seal (11.9 mm)	Thread Minor Dia:	0.120" (3.05 mm)

Performance Data^{1,2}

Material Strength

Tensile	1575 lbf / 7009 N
Shear	1035 lbf / 4606 N
Torsional	42 lbf-in / 4.7 N·m

Pull Out Strength Steel

16 Ga (1.5 mm)	389 lbf / 1730 N
14 Ga (1.9 mm)	783 lbf / 3483 N
12 Ga (2.7 mm)	1084 lbf / 4822 N

Pull Over Strength Steel

26 Ga (0.5 mm):	481 lbf / 2140 N
24 Ga (0.6 mm):	668 lbf / 2971 N
22 Ga (0.8 mm):	924 lbf / 4110 N

¹ SFS 3957.05

² PLK 22417

Installation and Application Considerations

Tools: 0–2000 rpm screw gun equipped with depth sensing nose piece.

Fastener length should provide for a minimum of 3/16" penetration of fully developed threads into metal substrate.

Use of impact guns or hammer drills is not recommended.