

**SPECIFICATION:**

JOSAM 88210 SERIES COATED CAST IRON DEEP SEAL 'P' TRAP WITH INDIRECT WASTE FUNNEL INLET AND THREADED SIDE OUTLET CONNECTION.

**TRAPS & ACCESSORIES**

DEEP SEAL TRAP, FUNNEL INLET

SERIES

**88210**

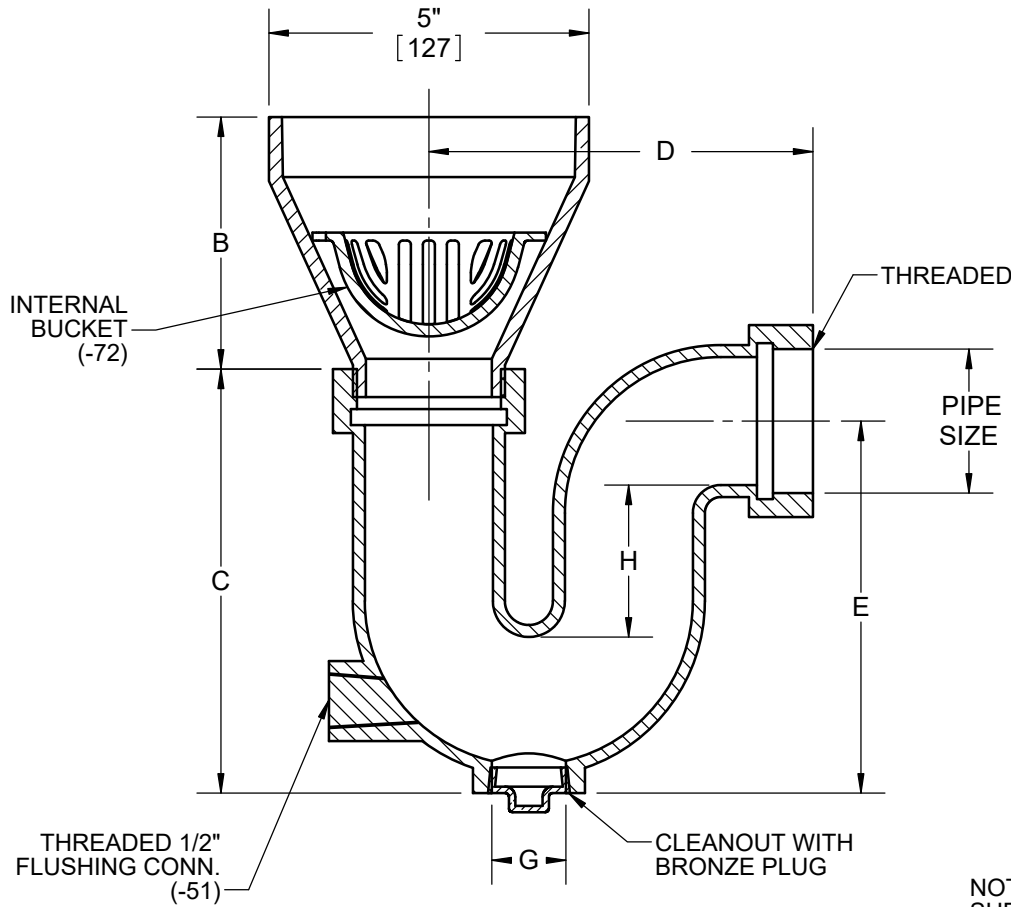
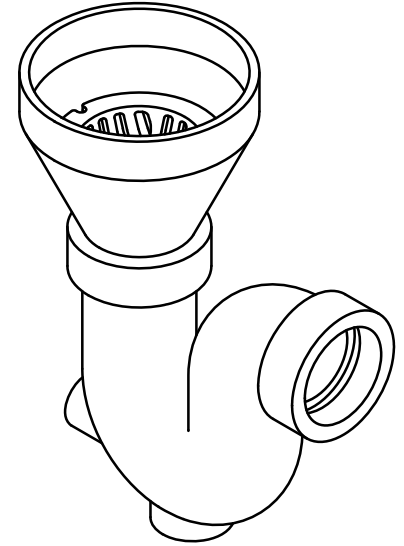
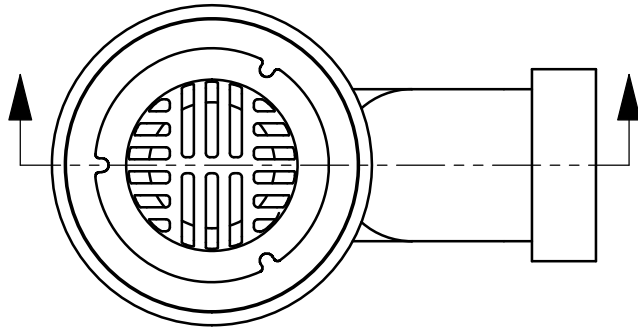

OPTIONS:

|     |                     |
|-----|---------------------|
| -8  | ALL BRONZE          |
| -51 | 1/2" FLUSHING CONN. |
| -72 | BRONZE BUCKET       |

NOTE:  
SUBJECT TO CODE REQUIREMENTS, A VACUUM BREAKER MAY NEED TO BE INSTALLED WHEN -51 OPTION IS SPECIFIED

| PIPE SIZE | B | C     | D     | E     | G | H     |
|-----------|---|-------|-------|-------|---|-------|
| 2"        | 4 | 6-5/8 | 6     | 5-3/4 | 1 | 2-3/8 |
| 3"        | 5 | 8-1/2 | 8-1/4 | 8     | 2 | 3-1/4 |

WARNING: Cancer and Reproductive Harm - www.P65Warnings.ca.gov

DATE OF LAST CHANGE: 06/28/18

DIMENSIONS ARE SUBJECT TO MANUFACTURERS TOLERANCES AND CHANGE WITHOUT NOTICE. WE CAN ASSUME NO RESPONSIBILITY FOR USE OF SUPERSEDED OR VOID DATA.



MICHIGAN CITY, INDIANA

NOTES