

LABOR SAVER® LAVATORY SUPPORTS WITH CONCEALED HANGERS

FLOOR MOUNTED UPRIGHTS

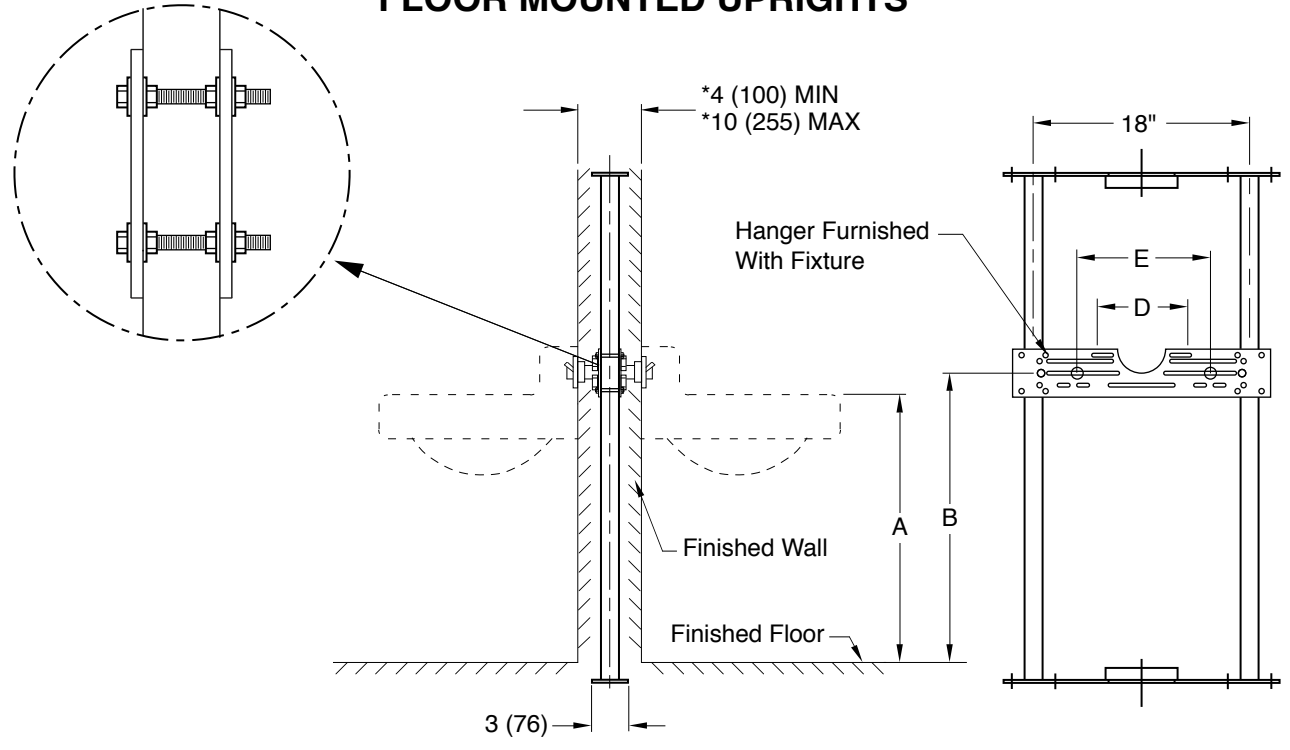
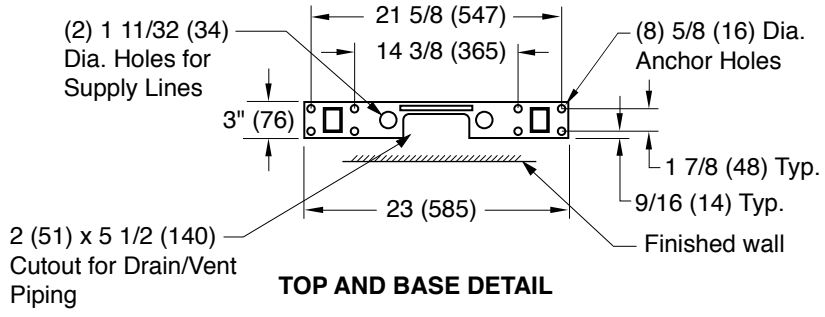

Fig. 0801D . . . FOR BACK TO BACK SUPPORT

NOTE: *This dimension can be increased when fixture support is to be installed behind the wall (specify when required and wall thickness).

NOTE: Dimensions shown in parentheses are in millimeters.

NOTE: The rough-in dimensions listed on this drawing are based on current information available to Jay R. Smith by the fixture manufacturers. We recommend that you verify these dimensions with the fixture manufacturer. We will not accept responsibility for rough-in dimension changes by the fixture manufacturer.



ROUGH-IN TABLE

FIXTURE MFG.	NAME	NUMBER	SIZE	A	B	D	E

0801D

FIGURE NUMBER	B A	5-3-03 07/31/02	Revised Table Revised View	TBW JJ	AM AM	WEIGHT POUNDS	VOLUME CUBIC FEET	FIGURE NUMBER 0801D
	REV.	DATE	DESCRIPTION	BY	CKD. BY			

DIMENSIONS ARE SUBJECT TO MANUFACTURERS TOLERANCE AND CHANGE WITHOUT NOTICE

DRAWING NUMBER S0801D
SCALE: NONE
DATE: 07/22/02
APPROVED BY: AM
CHECKED BY: CR
DRAWN BY: JJ

WE CAN ASSUME NO RESPONSIBILITY FOR USE OF SUPERSEDED OR VOID DATA