

SPECIFICATION:

JOSAM 17380-M1710 SERIES FLOOR-MOUNTED, LAVATORY DECK CARRIER WITH EXPOSED ACID-RESISTING WHITE COATED ARMS, LEVELING AND SECURING SCREWS, STRUCTURAL UPRIGHTS, WELDED FEET AND CHROME PLATED TRIM.

**LAVATORY CARRIER
FLOOR-MOUNT EXPOSED ARM**

SERIES **17380-M1710**

DESIGNED FOR BRADLEY LD-3010-3 LAV DECK

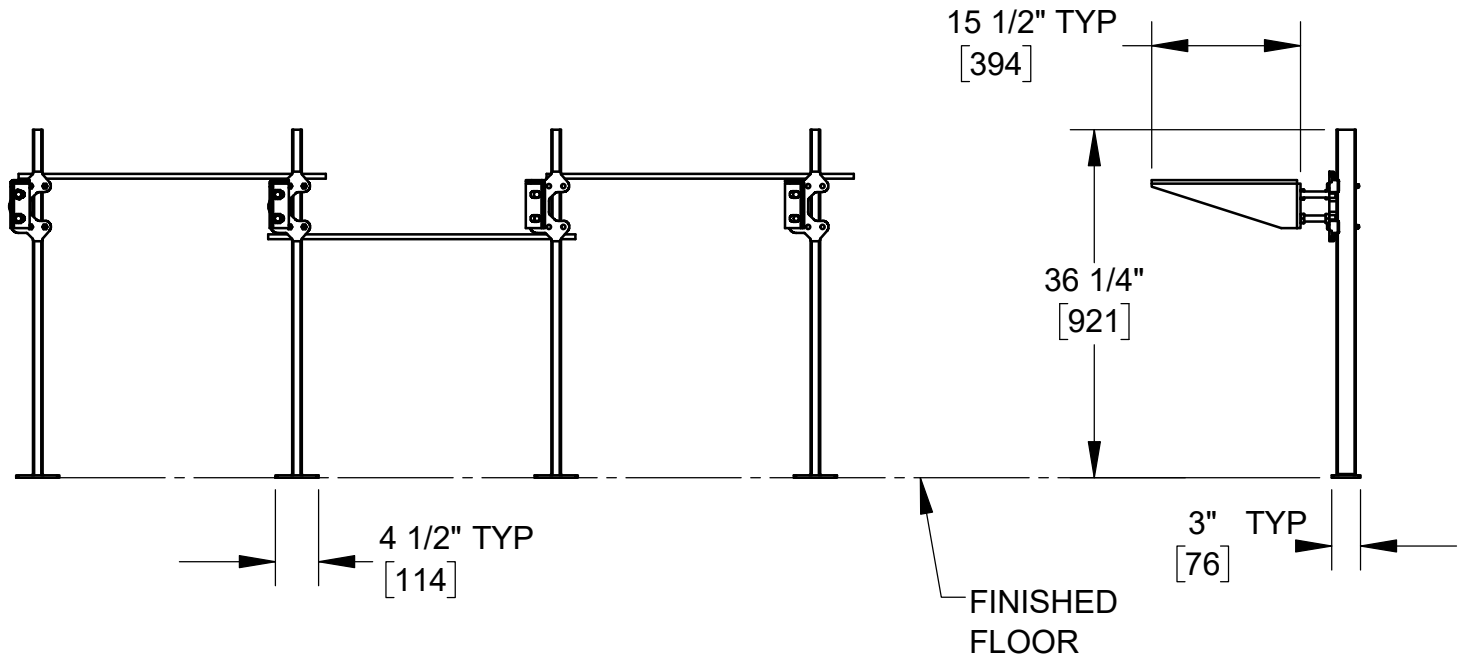
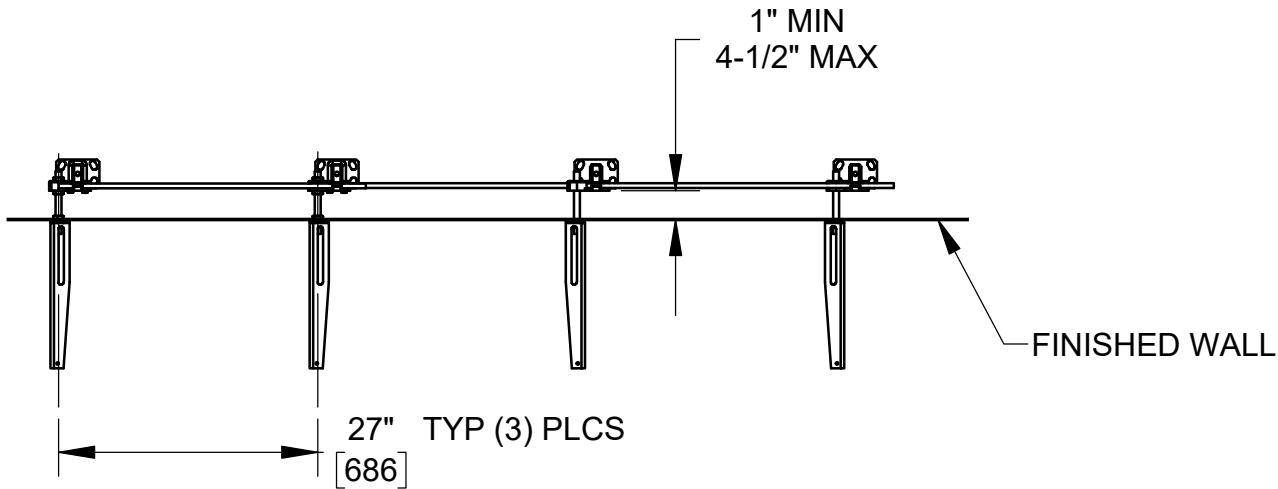
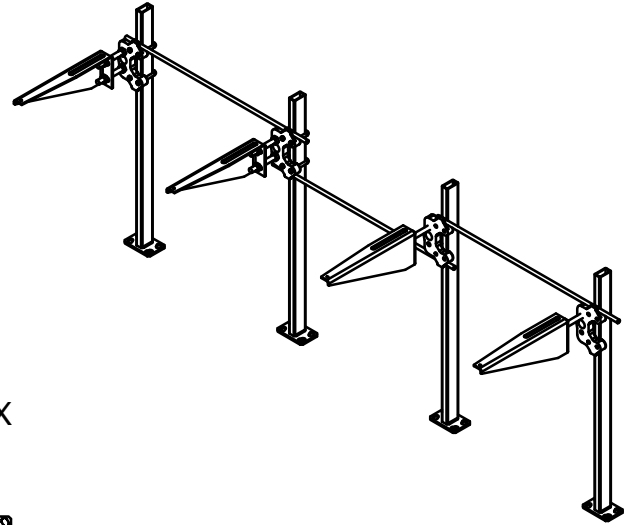

RECOMMEND ALL FEET BE SECURED TO FLOOR WITH 1/2" BOLTS AND ANCHORS BY OTHERS.

WARNING: Cancer and Reproductive Harm - www.P65Warnings.ca.gov

DATE OF LAST CHANGE: 06/05/18

DIMENSIONS ARE SUBJECT TO MANUFACTURERS TOLERANCES AND CHANGE WITHOUT NOTICE. WE CAN ASSUME NO RESPONSIBILITY FOR USE OF SUPERSEDED OR VOID DATA.



MICHIGAN CITY, INDIANA

NOTES