

## INSTRUCTIONS FOR MODELS

SC-3002-8-LD  
SC-3002-8-LD-E  
SC-3004-8-LD  
SC-3004-8-LD-E  
SC-3004-FC-LD  
SC-3004-LD  
SC-3004-LD-E

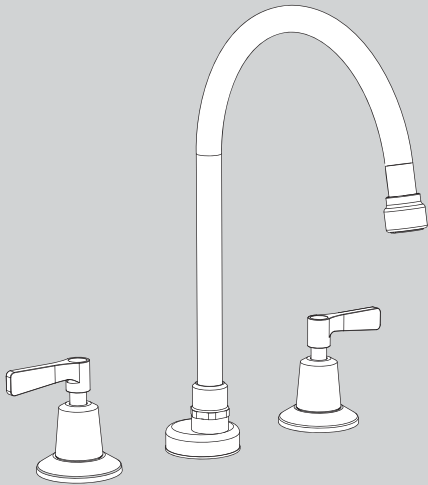

### NEED HELP?

For additional assistance or service please contact:

**SPEAKMAN®**

800-537-2107

customerservice@speakman.com

www.speakman.com

92-SC-300X-LD-05

## TOOLS AND SUPPLIES

Phillips  
Screwdriver

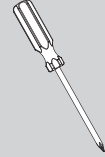

Adjustable  
Wrench

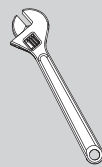

Slip Joint  
Wrench



Aerator  
Wrench  
(supplied)

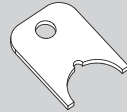

### HELPFUL TOOLS & SUPPLIES:

Supply  
Hoses



Tubing  
Cutter

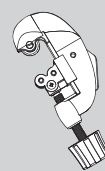

Basin  
Wrench

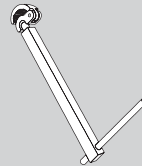

Thread Seal  
Tape



Safety  
Glasses



Solder Kit

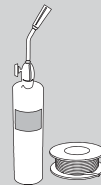

## IMPORTANT



This installation manual covers several models. While the appearance of your faucet may vary, the installation steps required are the same as shown in this manual.



Be sure to read instructions thoroughly before beginning installation.



Do not overtighten any connections or damage may occur.



This faucet has an operating range of 20-80 psi.

### SAFETY TIPS



Cover your drain to prevent loss of parts. Be sure to wear eye protection while cutting pipe.

### MAINTENANCE



Your new Speakman Product is designed for years of trouble-free performance. Keep it looking new by cleaning it periodically with a soft cloth. The use of harsh chemicals and abrasives on any of the Speakman custom finish products may damage the finish and void the product warranty. Please be sure to only use approved cleaners. Please contact Speakman for any clarification of acceptable cleaners.

### WARRANTY



Warranty information can be found at:  
[www.speakman.com](http://www.speakman.com)

**1**

Remove the Compression Nuts (1) from the inlets of the end body valves.

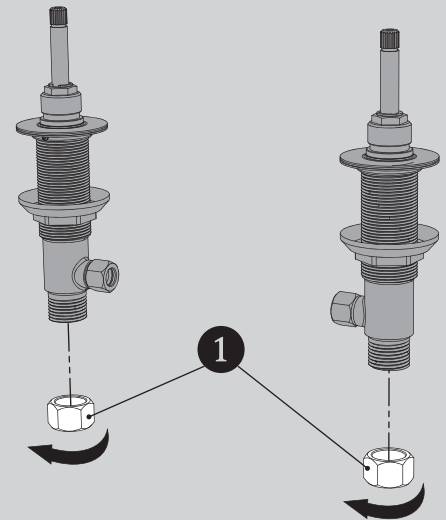

**2**

Remove Compression Nuts (1) from End Bodies. Retrieve the Tee Assembly bag group. Slide a Compression Nut (1), followed by a Compression Sleeve (2) over the copper pipe of each end of the Tee Assembly.

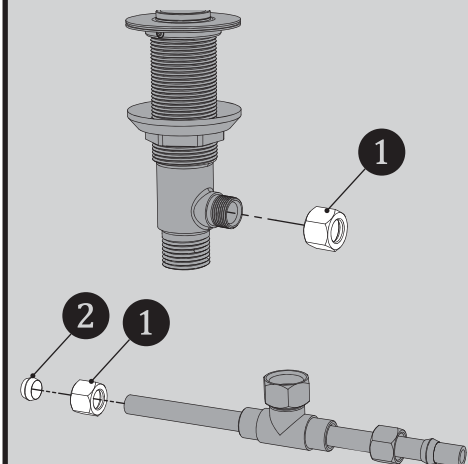

**3** Bench assemble the Tee to the HOT and COLD end body valves. Be sure to fully seat the copper piping into the end body valves, and hand tighten Compression Nuts (1) to the outlet ports. Be sure the end body valves are perpendicular to the Tee assembly.

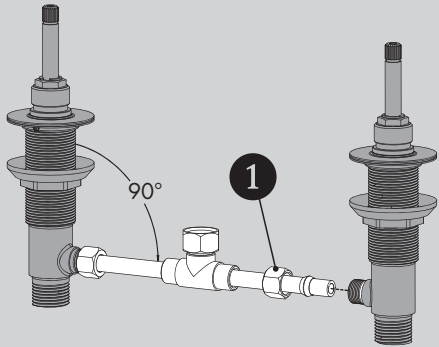

**4** Insert and position the Gooseneck Flange (1) with Gasket (2) down through the center hole of the sink or counter top, being sure the cut out of the gasket is aligned to the rear of the faucet. Assemble Rubber Washer (3), Metal Channel Washer (4) and Mounting Nut (5) to shank and thread only half way up the shank.

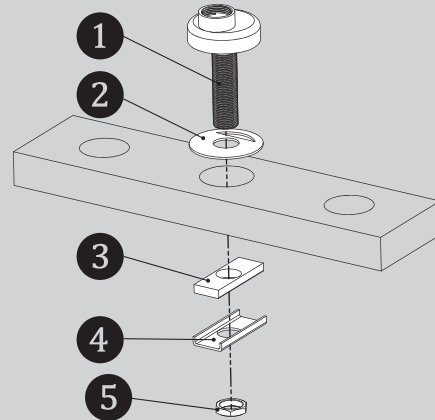

**5** Loosen the Set Screws (1) and remove the end body valve Flange Nuts (2) and Rubber Washers (3). Screw the Locknuts (4) and Cup Washers (5) down on end body valves.

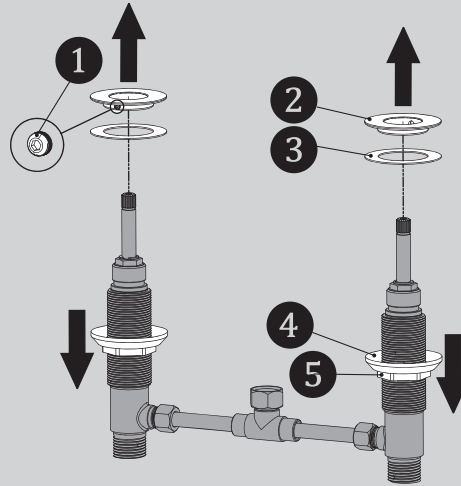

**6** From below the counter top, push the end body with tee assembly up through the outer holes in the sink or counter top.  
**NOTE:** Blue colored end body (COLD) should be on the right side of tee assembly, Red colored end body (HOT) on the left. Hand tighten the tee assembly's Swivel Nut (2) to the Shank (1) of the gooseneck flange.

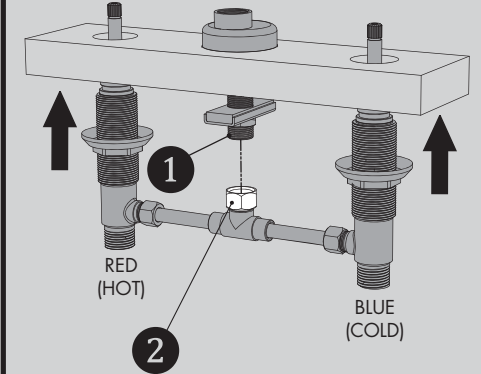

**7** While lifting the end body with tee assembly up by its spindles, replace the Rubber Washers (1) and screw the Flange Nuts (2) back onto the end body valves, with flat side up, till they are flush with the tops of the 1-1/8"-16 UN threads of the end body valves.

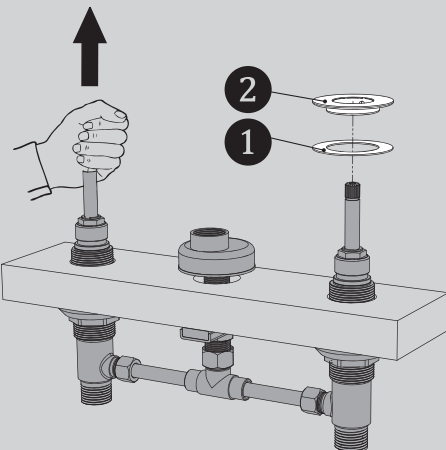

**8** Ensure the Flange Nuts (1) are flush with the tops of the 1-1/8"-16 UN threads, then tighten Set Screws (2).

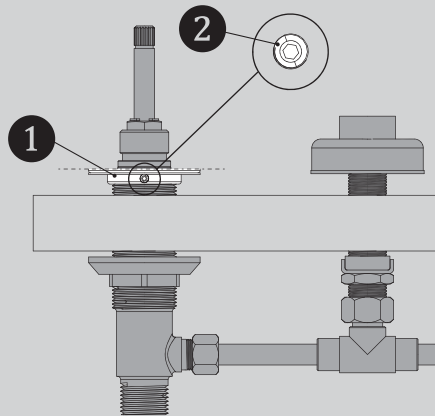

**9** From below, Wrench Tighten the Gooseneck Flange Nut (1) with Channel Washer/Spacer (2), Tee Swivel Nut (3), end body valve Locknuts (4) with Cup Washers (5), and two (2) Tee Compression Nuts (6) at the outlets of the end body valves to secure the entire unit and prevent leaks.

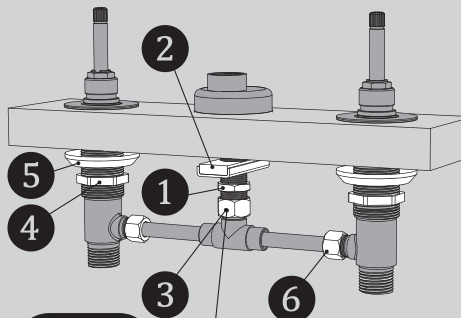

**NOTE:** Do Not Overtighten Swivel Nut

**10** Connect water supply lines to inlets (1/2"-14 NPSM male threads) of the end body valves and wrench tighten coupling nuts to prevent leaks.

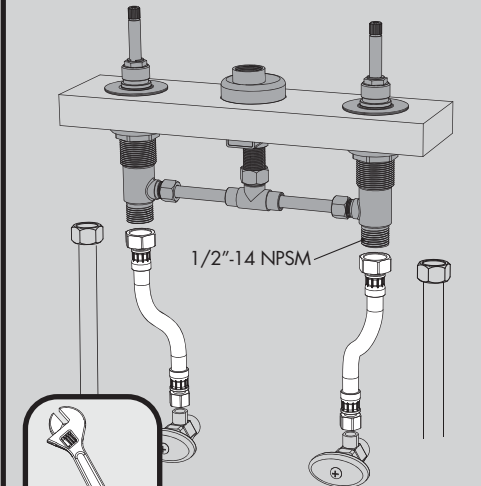

**NOTE:** Flex Hoses and Shut Off Valves **not** included.

**11** From above the sink, place decorative Flange (1), then screw Escutcheon (2) onto end body valve assemblies and hand tighten. Slip Trim Sleeves (3) onto spindles. Position Handles (4), Lock Washers (5) (SC-3004 series) and use Screws (6) to secure to spindles. Position Index Buttons (7) on handles (blue on right handle, red on left handle) and press into place.

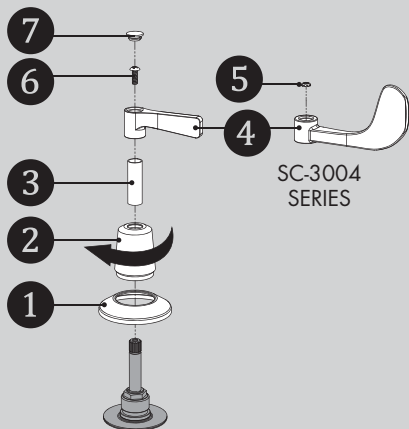

**12** Assemble gooseneck to flange assembly by wrench tightening Gooseneck Collar Nut (1). **NOTE:** For rigid gooseneck, place Locking Washer (2) from hardware bag group into flange outlet before assembling gooseneck.

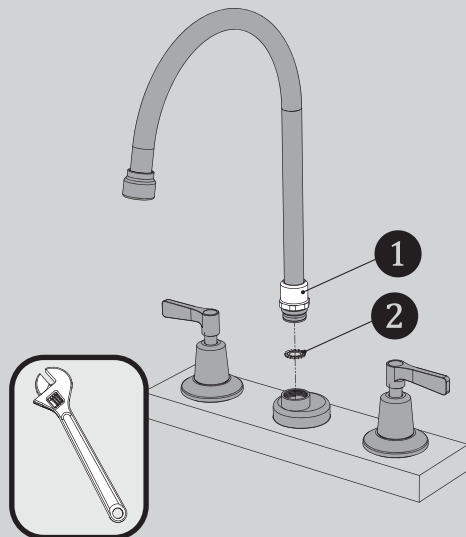

**13** Turn on water supplies and flush both HOT and COLD cartridges for one minute, while checking for leaks. Once completed, install aerator into spout end using supplied aerator wrench.

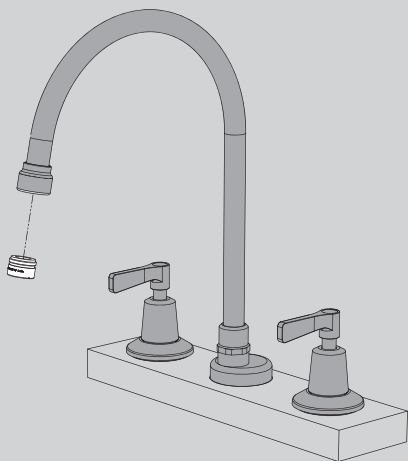

**NOTE:** If installing SC-3004-FC-LD, this model does not use an aerator.

### LAVATORY ROUGH IN

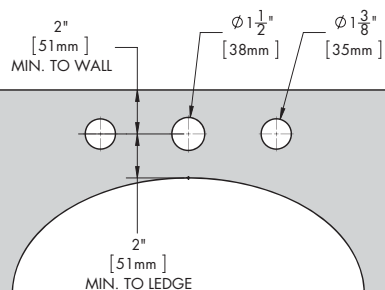

### SC-300X-LD REPAIR PARTS

**SPEAKMAN®**

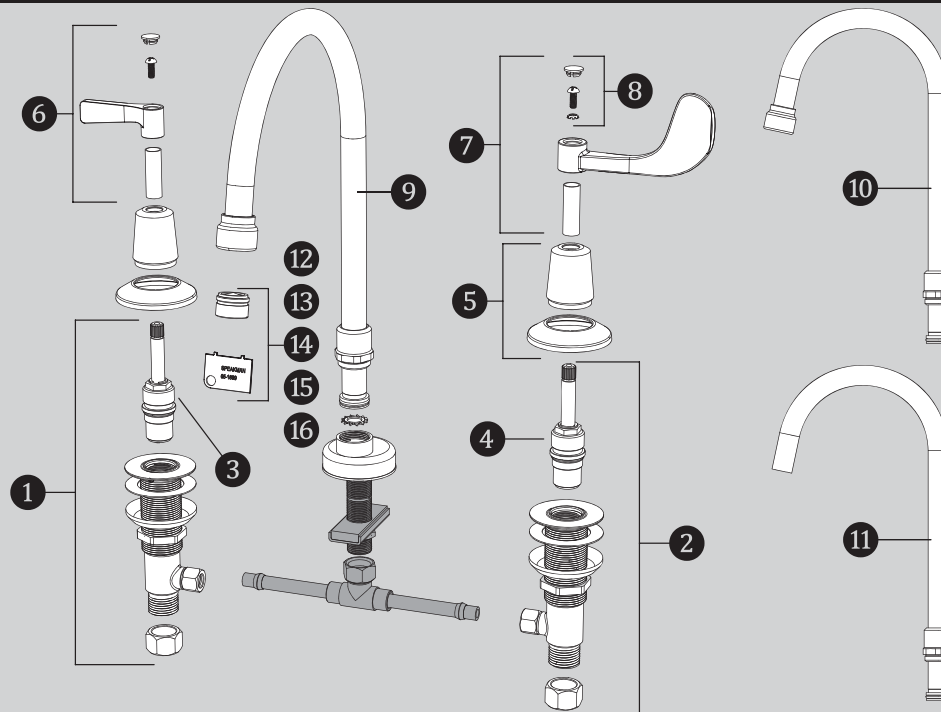

ITEM NO.	PART NO.	DESCRIPTION
1	RPG20-2011-CA	END BODY ASSEMBLY (RED) W/ MOUNTING HARDWARE & HOSE ADAPTER
2	RPG20-2012-CA	END BODY ASSEMBLY (BLUE) W/ MOUNTING HARDWARE & HOSE ADAPTER
3	RPG05-0534-CA	PERFECT VALVE GROUP (RED) WITH TRIM SLEEVE & SCREW
4	RPG05-0535-CA	PERFECT VALVE GROUP (BLUE) WITH TRIM SLEEVE & SCREW
5	RPG10-0070-PC	TRIM COLLAR & FLANGE GROUP
6	RPG04-0320-PC	METAL LEVER HANDLE GROUP
7	RPG04-0316-PC	4" WRIST BLADE HANDLE GROUP
8	RPG41-0285	RED, BLUE, & CHROME INDEXES WITH SCREWS & LOCK WASHERS
9	G18-0217-CA	8" GOOSENECK ASSEMBLY (INCLUDING O-RING)
10	RPG18-0213-CA	5" GOOSENECK ASSEMBLY (INCLUDING O-RING)
11	G18-0212-CA	5" FC GOOSENECK ASSEMBLY (INCLUDING O-RING)
12	RPG05-0837-PC	1.5 GPM (5.7 L/min) AERATOR ASSEMBLY WITH WRENCH
13	RPG38-0128-PC	BOCA 0.5 GPM FLOW OUTLET ASSEMBLY WITH WRENCH (-E)
14	RPG05-0851-PC	1.5 GPM (5.7 L/min) LAMINAR FLOW OUTLET ASSEMBLY WITH WRENCH
15	A-EA12	1.2 GPM (4.5 L/min) AERATOR ASSEMBLY WITH WRENCH
16	A-ELF	1.2 GPM (4.5 L/min) LAMINAR FLOW OUTLET ASSEMBLY WITH WRENCH

### SC-3002-8-LD ROUGH-IN DIAGRAM

**SPEAKMAN®**

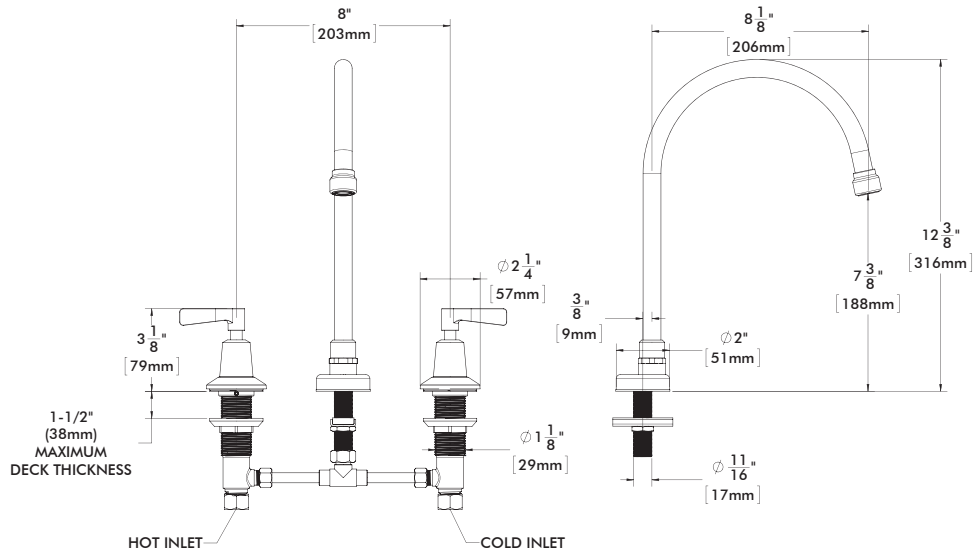

DIMENSIONS SUBJECT TO CHANGE WITHOUT NOTICE.

### SC-3004-FC-LD ROUGH-IN DIAGRAM

**SPEAKMAN®**

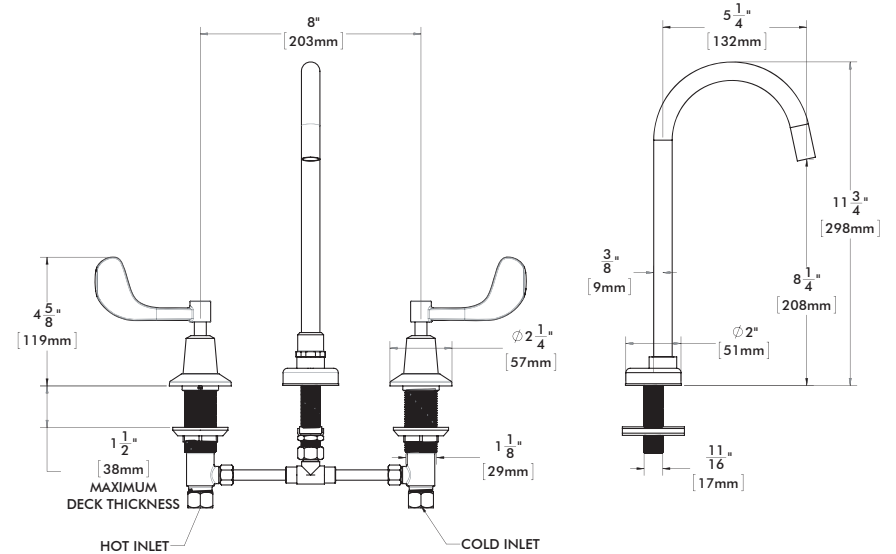

DIMENSIONS SUBJECT TO CHANGE WITHOUT NOTICE.

### SC-3004-8-LD ROUGH-IN DIAGRAM

**SPEAKMAN®**

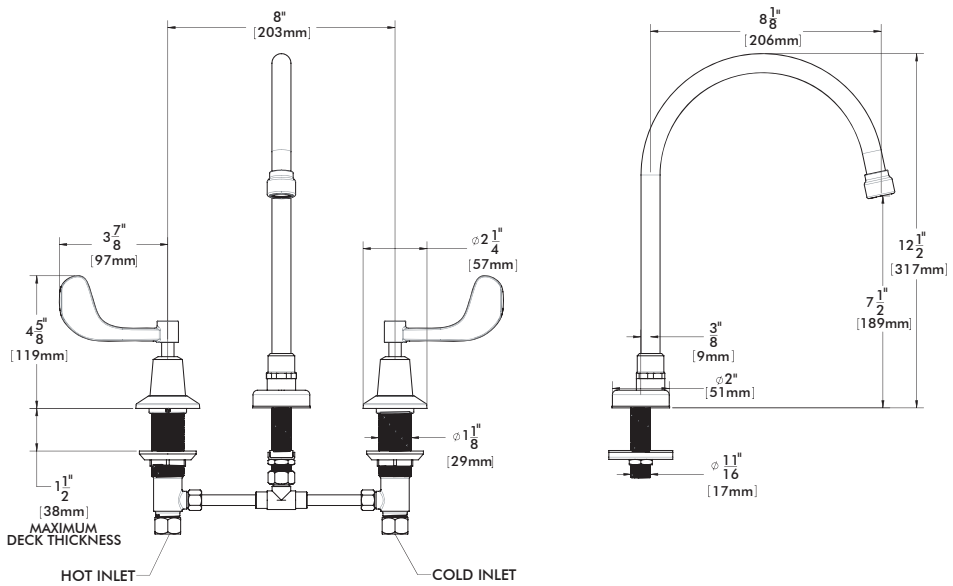

DIMENSIONS SUBJECT TO CHANGE WITHOUT NOTICE.

### SC-3004-LD ROUGH-IN DIAGRAM

**SPEAKMAN®**

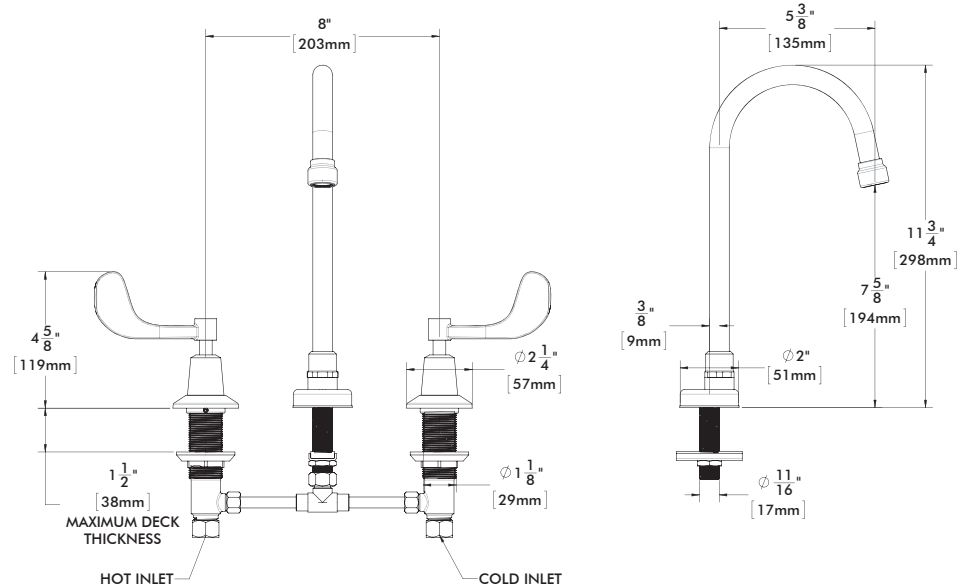

DIMENSIONS SUBJECT TO CHANGE WITHOUT NOTICE.