

# FIXTURE SUPPORTS

## FIG. 0800, 0805 LAVATORY SUPPORTS FLOOR MOUNTED TYPE SUPPORTS WITH SUPPORTING PLATE & HARDWARE

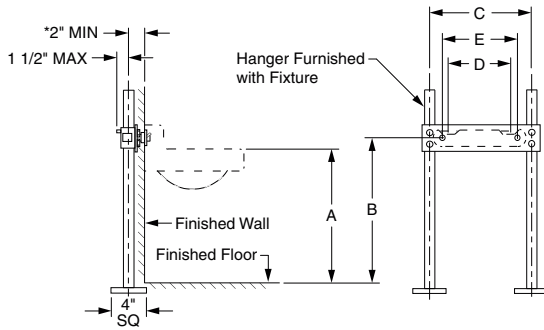

FIXTURE SUPPORTS



**Fig. 0800**

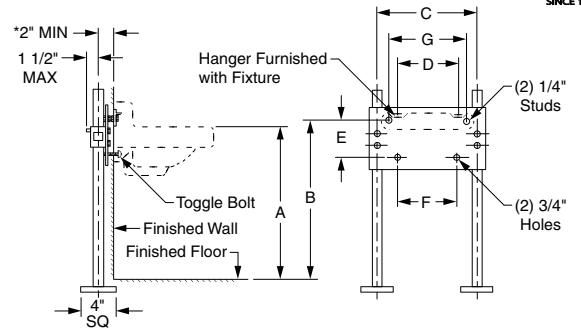

**Fig. 0805**



\*This dimension can be increased when fixture support is to be installed behind the wall (specify when required and wall thickness).

**NOTE:** For metal stud wall construction, specify Suffix -M31 rectangular steel upright with welded base for greater strength.

For lettered dimensions contact factory.

FIGURE NO.	DESCRIPTION	PRICE	APPROX. WT. LBS.
0800	With Bar Hanger	751.00	26
0805	With Bar Hanger & Bottom Securing Lugs	POA	17

FOR INFORMATION ON POA ITEMS, PLEASE CONTACT YOUR LOCAL JAY R. SMITH REPRESENTATIVE

## FIG. 0801, 0801D LABOR SAVER® LAVATORY SUPPORTS FLOOR MOUNTED TYPE SUPPORTS WITH SUPPORTING PLATE & HARDWARE

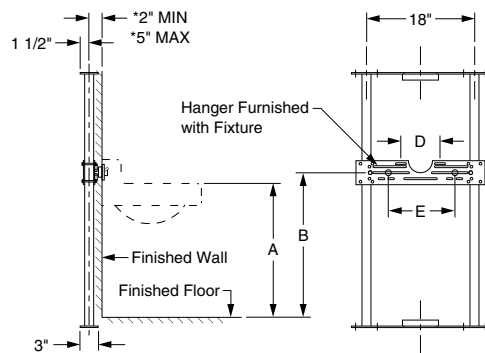

**Fig. 0801**

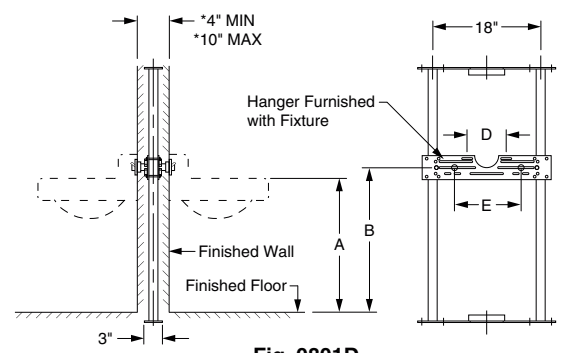

**Fig. 0801D**

\*This dimension can be increased when fixture support is to be installed behind the wall (specify when required and wall thickness).

For lettered dimensions contact factory.

FIGURE NO.	DESCRIPTION	PRICE	APPROX. WT. LBS.
0801	Single-With Bar Hanger	976.00	26
0801D	Double-With Bar Hanger	1,296.00	35

**NOTE:** Service weight regularly furnished on fittings above.  
**NOTE:** Always specify fixture manufacturer's model name and number.