



## DRINKING FOUNTAINS INSTALLATION/MAINTENANCE INSTRUCTIONS

### A910.8A Remote Water Chiller, 8 GPH



A9100080-A / A9100080-A-220V

**TECHNICAL ASSISTANCE TOLL FREE TELEPHONE NUMBER:  
1.800.591.9360**

Technical Assistance Fax: 1.626.855.4894

#### NOTES TO INSTALLER:

1. Please leave this documentation with the owner of the fixture when finished.
2. Please read this entire booklet before beginning the installation.
3. Check your installation for compliance with plumbing, electrical and other applicable codes.

#### LIMITED WARRANTY - UNITED STATES & CANADA

Murdock warrants that every cooler, bottle filling station, packaged water chiller, fountain and accessory to be free from defects in material and workmanship under normal use for one (1) year from date of install or eighteen (18) months after the date of shipment from the factory, whichever comes first.

Murdock warrants the compressor and hermetically sealed refrigeration system, including cooling coil assembly when part of the hermetically sealed refrigeration system, to be free from defects in material and workmanship under normal use for an additional four (4) years from the end of the one (1) year period described above.

This warranty does not cover installation or labor charges and does not apply to materials, which have been damaged by other causes such as mishandling or improper care or abnormal use. The repair or replacement of the defective materials shall constitute the sole remedy of the Buyer and the sole remedy of Murdock under this warranty. Murdock shall not be liable under any circumstances for incidental, consequential or direct charges caused by defects in the materials, or any delay in the repair or replacement thereof. This warranty is in lieu of all other warranties expressed or implied. Product maintenance instructions are issued with each unit and disregard or non-compliance with these instructions will constitute an abnormal use condition and void the warranty. Stainless steel must be protected on job site during construction and must be properly maintained after the water has been introduced into the water cooler or drinking fountain, or Murdock's limited warranty is void.

**LIMITED EXPORT WARRANTY - One year on parts only.**

Murdock assumes no responsibility for use of void or suspended data. © Copyright Murdock, City of Industry, CA Member of Morris Group International. Please visit [www.murdockmfg.com](http://www.murdockmfg.com) for most current specifications.

COMPLIES WITH  
STANDARDS



NSF/ANSI 61



Test rating conditions are  
compliant with ARI 1010.



Federal  
Public Law  
111-380  
(No Lead)



Member of  
MORRIS GROUP  
INTERNATIONAL

**MURDOCK**  
15125 Proctor Ave.  
City of Industry, CA  
91746 U.S.A.  
Phone 800-591-9360  
626-336-4561  
Fax 626-855-4894

[www.murdockmfg.com](http://www.murdockmfg.com)

7020-900-001

Date: 09/04/18



# DRINKING FOUNTAINS

## INSTALLATION/MAINTENANCE INSTRUCTIONS

### IMPORTANT

This fixture is intended to dispense water that has been lowered in temperature, but otherwise remains unchanged by the materials in the water cooler. It is common for electrical equipment to be grounded to water lines either within a structure or away from it. Every attempt should be made to prevent this kind of grounding from generating electrical feedback into the water cooler creating electrolysis. Electrolysis will cause a metallic taste or cause water metal content to increase.

### NOTICE

Remote water chiller is intended for indoor installation (fixture has not been rated for outdoor installation). A dielectric coupling must be used to connect the water chiller to the water supply. A nonmetallic coupler is furnished with this water cooler to meet this requirement.

### ROUGHING-IN AND DIMENSIONAL DRAWING

Prior to roughing consult with local, state, and federal codes for proper compliance.

#### ROUGH-IN:

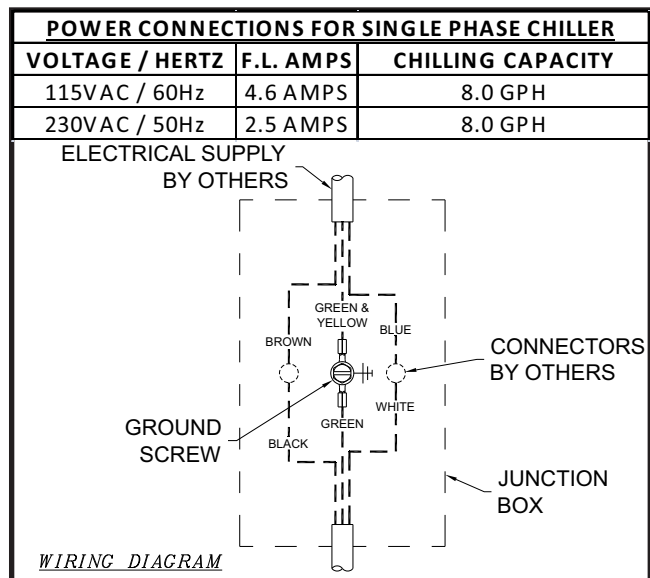
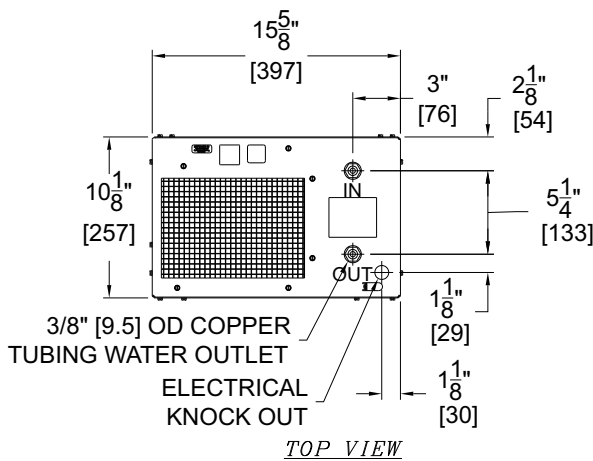

**NOTE: INSTALLER MUST REMOVE THE REMOVABLE ACCESS PANEL TO LOCATE THE JUNCTION BOX TO MAKE UP WIRING CONNECTIONS**

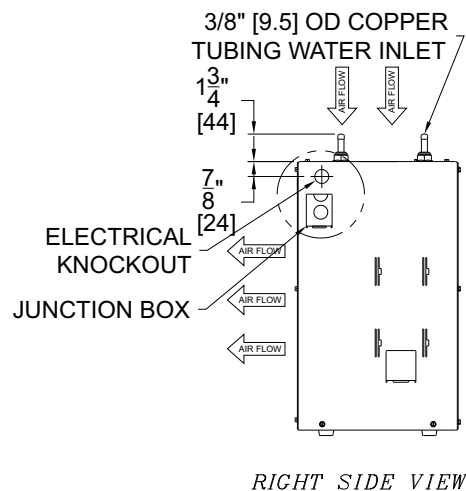
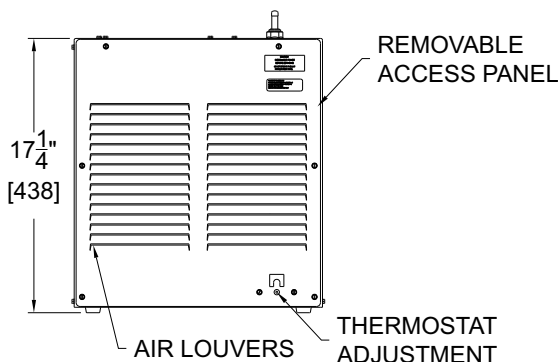

**GENERAL NOTES:**

1. ALL DIMENSIONS ARE IN INCHES [MM].
2. ALLOW 4 INCHES [102MM] MINIMUM CLEARANCE ON TOP AND FRONT FOR VENTILATION.
3. IT IS RECOMMENDED THAT ALL WATER OUTLETS BE CONNECTED DIRECTLY AND NO MORE THAN 7 FEET AWAY FROM THE CHILLER. FOR ANYTHING GREATER THAN 7 FEET, CHILLED WATER MAY NOT BE EXPOSED UNTIL ALL WATER IN RISER HAS BEEN RELEASED. ALL CHILLED WATER PIPING IS INTENDED TO BE COVERED WITH APPROPRIATE INSULATION TO MAINTAIN TEMPERATURE AND AVOID CONDENSATION



## DRINKING FOUNTAINS INSTALLATION/MAINTENANCE INSTRUCTIONS

### **IMPORTANT:**

1. Water Supply Service Stop Valve, Water Connections and Electrical Connections to be supplied by others in accordance with local codes.
2. Provide 4" minimum clear space on fixture top and front to allow for proper ventilation.
3. Water inlet and chilled water outlet is 3/8" OD tube (or 1/4" NCT).
4. Completely flush supply lines of all foreign debris before connecting to chiller. Water chiller is designed to be free of problems with taste, odor, or sediment.
5. All burrs must be removed from outside of cut tubes before inserting into all components.
6. Power supply must be identical in voltage, cycle and phase to that specified on the chiller data plate.
7. This unit must be grounded per the requirements of applicable electrical codes.
8. **WARNING:** Failure to follow current Acorn Drinking Fountains installation instructions or using chiller in a manner not approved by Acorn Drinking Fountain will render warranty void.
9. Chiller operates within water pressure range of 20 to 105 psig. Acorn Drinking Fountains will not warranty chiller damages when connected to supply lines with flow pressure lower than 20 psig or higher than 105 psig. A pressure regulator must be furnished by others on supply line if inlet pressure is greater than 105 psig.
10. Remote water chiller is intended for indoor installation (fixture has not been rated for outdoor installation).

### **INSTALLATION:**

1. Locate chiller where there is 4 inches of space in front and above the chiller for proper ventilation.
2. Remove front panel of chiller and make the necessary electrical connections (per the chiller data label) including the ground connection. Make sure the supply power is off.
3. Reinstall front panel with six sheet metal screws.
4. Connect the water supply stop (by others) to the inlet on top of the chiller. Make sure the water supply lines are thoroughly flushed of any debris before connecting to chiller.
5. Connect the outlet on top of the chiller to the fixture(s) requiring chilled water. All tubing supplying chilled water must be covered with appropriate insulation to maintain temperature and avoid condensation.
6. Tubing connections to fixtures should be direct and no longer than seven feet.

### **START UP:**

1. Before connecting power supply, but after thoroughly flushing the supply line and connecting it to the chiller, turn on building water supply and check all connections for leaks.
2. Air within the water chiller system or the structure supply piping will cause an irregular outlet stream until purged out by incoming water. Cover the outlet of fixture to which to which chiller is connected with a clean cup(or similar object) is recommended when first activating water chiller to prevent excessive splashing. Activate fixture valve until steady water stream is achieved.
3. Recheck all water connections with water flowing through system for leaks.
4. Provide power to chiller and make sure until begins to function.

### **CLEANING & MAINTENANCE GUIDE:**

1. Motors have lifetime lubrication and do not require scheduled maintenance.
2. Excess dirt or poor ventilation will cause the compressor overload protector to turn the compressor off and it will cycle on and off with no cold water coming out of bubbler. Periodically clean with vacuum cleaner, air hose or brush the condenser fins and cabinet ventilation louvers. In environments where dirt and dust is more prevalent, clean more frequently.



## DRINKING FOUNTAINS

### INSTALLATION/MAINTENANCE INSTRUCTIONS

#### **TROUBLE SHOOTING:**

**IMPORTANT: BEFORE MAKING ANY OF THE REPAIRS LISTED, MAKE SURE THE WATER CHILLER IS DISCONNECTED FROM THE ELECTRICAL SUPPLY AND THE WATER SUPPLY VALVE IS SHUT OFF.**

1. Adjustments
  - a. Cold Water Thermostat – The water temperature can be adjusted using a slotted screwdriver and turning clockwise to make colder and counterclockwise to make warmer.
2. Compressor Does Not Run
  - a. Check the electrical supply for power and correct voltage. The incoming voltage must be within 10% of the rated voltage on the serial nameplate.
  - b. If the cold thermostat capillary bulb loses its charge or becomes kinked it will fail in the open position cause a disruption of power to the compressor. Unplug the water chiller and using an ohm meter check for continuity.
  - c. Check for loose wires within the compressor box. The incoming power leads must be connected to the overload relay.
  - d. If all components check positive for continuity then test the wiring harness plug for continuity to see if there is a broken wire within the wiring harness insulation.
3. Compressor Runs – Water is Warm
  - a. The most common cause for a water chiller to run without producing cold water is a loss of refrigerant. The water chiller must be taken to a certified refrigerant technician for repairs.
  - b. Make sure the condenser fan motor is operative. The fan blade must turn freely to help remove the heat of compression.
  - c. An incorrect refrigerant charge, restriction or defective compressor (not pumping) will also cause the compressor to run without producing cold water. All these signs indicate a problem within the refrigerant system and the water chiller must be checked by an authorized service company.
4. Compressor Cycling On Overload protector
  - a. A dirty condenser or a blocked fan will cause a high head pressure and frequent cycling of the overload protector.
  - b. Check the incoming voltage to make sure it is within 10% of the serial nameplate rating.
  - c. A restriction or moisture in the system will also cause intermittent cycling. A certified refrigerant mechanic should be contacted in this situation.
  - d. Change the overload or relay if defective.
5. Noisy Operation
  - a. Check to make sure the fan blade is rotating freely.
  - b. Check the compressor mounting to make sure the pins and clips are not rattling. If the compressor appears to be noisy internally, it must be replaced.
6. Restricted Or No Water Flow
  - a. Ensure water supply service stop valve is fully open.
  - b. Verify minimum 20psig supply line flow pressure
  - c. Check for twists or kinks in outlet tubing.
  - d. Fixture to which chiller is attached might be clogged with foreign material.
  - e. The water chiller may also develop a freezing condition in which the water will become frozen inside the evaporator coil. This indicates a refrigeration problem or thermostat failure in which case the water chiller needs to be checked by a qualified technician.



# DRINKING FOUNTAINS

## INSTALLATION/MAINTENANCE INSTRUCTIONS

### **PUSH-IN FITTING INSTALLATION**

NOTE: FITTINGS AND TUBE SHOULD BE KEPT CLEAN, BAGGED AND UNDEMANAGED PRIOR TO INSTALLATION.

#### **TO CUT TUBE:**

Cut to fit length of 1/4" PE tubing and remove any burrs or sharp edges. Ensure that the outside diameter is free from score marks. Tube ends should be square.

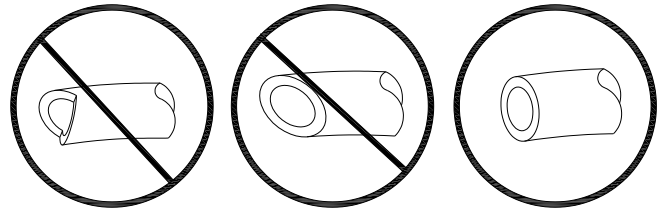

#### **INSERTING THE TUBE:**

1. Firmly and fully insert the tubing end into the push-in fitting up to the tube stop located approximately 1/2" deep.

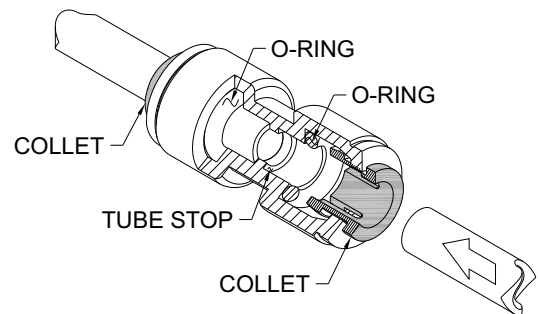

2. Pull on the fitted tubing to ensure it is secure. Tube should not come free from the fitting. Water test the connection assembly prior to leaving the site to ensure there are no leaks.

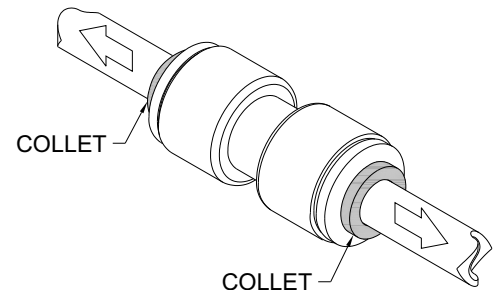

#### **DISCONNECTING THE TUBE:**

To disconnect the tube from the fitting ensure that the water line is depressurized. Push collet square towards the push-in fitting body and hold. While holding the collet in, pull on the PE tubing to remove from the push-in fitting.

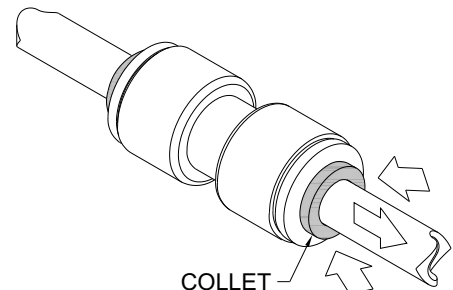



# DRINKING FOUNTAINS

## INSTALLATION/MAINTENANCE INSTRUCTIONS

### PART LIST - 110VAC

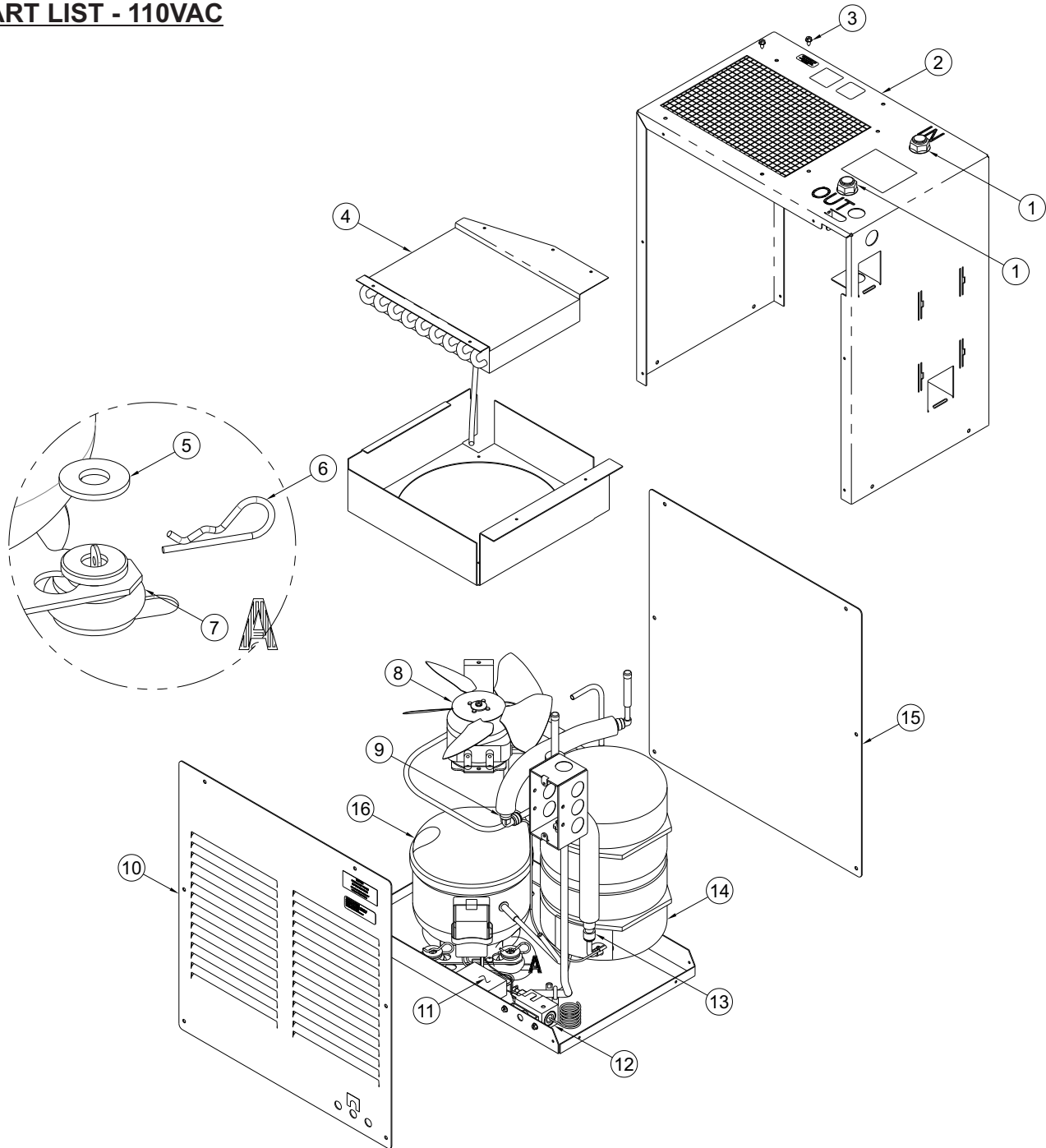

ITEM#	PART NUMBER	DESCRIPTION	ITEM#	PART NUMBER	DESCRIPTION
1	1895-712-000	3/8"OD - 1/4" OD BULKHEAD CONNECTION	9	1895-708-000	1/4" OD PUSH-IN ELBOW CONNECTION
2	7008-010-199	HOUSING	10	7008-012-199	FRONT PANEL
3	0124-031-000	#8-3/8" HEX WASHER HD SLOTTED SCREW	11	7012-803-000	CAPACITOR
4	7008-015-001	CONDENSOR ASSEMBLY	12	7003-250-000	TEMPERATURE CONTROL
5	0332-013-000	1" OD x 7/16" ID FLAT WASHER	13	1895-121-000	1/4" OD PUSH-IN CONNECTION
6	7012-150-000	3/32" x 1-5/8" HITCH PIN	14	7003-115-001	EVAPORATOR ASSEMBLY
7	7012-805-000	RUBBER FOOT FOR TATUNG	15	7008-013-199	BACK PANEL
8	7003-002-004	115V FAN MOTOR	16	7012-801-001	115V COMPRESSOR ASSY

**MURDOCK MFG.** • 15125 Proctor Avenue • City of Industry, CA 91746 USA  
 Phone 800-453-7465 or 626-333-2543 • Fax 626-855-4860 • www.murdockmfg.com

Member of  
 MORRIS GROUP  
 INTERNATIONAL





# DRINKING FOUNTAINS

## INSTALLATION/MAINTENANCE INSTRUCTIONS

### PART LIST - 220VAC

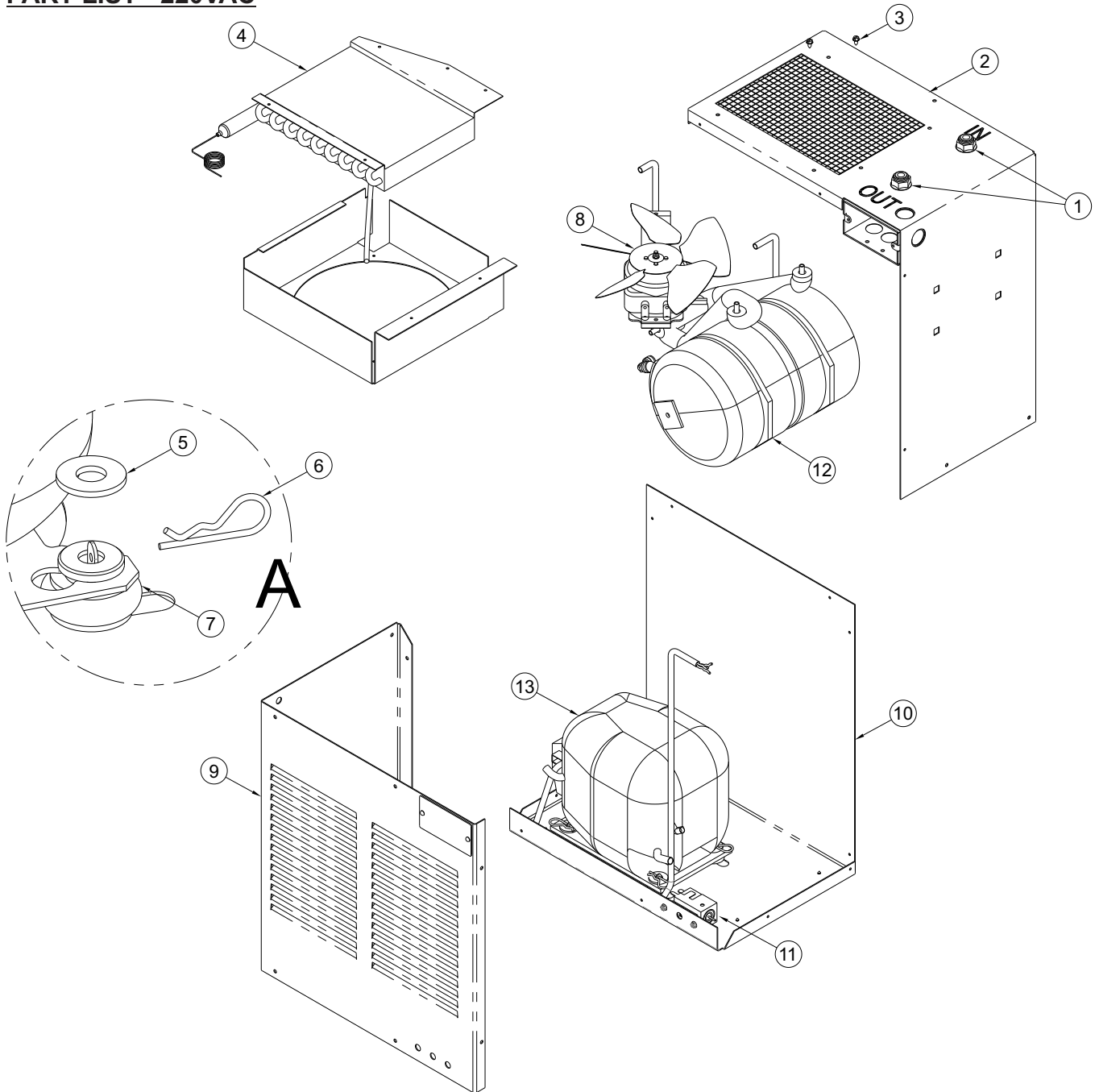

ITEM#	PART NUMBER	DESCRIPTION	ITEM#	PART NUMBER	DESCRIPTION
1	1895-712-000	3/8"OD - 1/4" OD BULKHEAD CONNECTION	8	7003-700-005	220V FAN MOTOR
2	7008-050-004	HOUSING ASSEMBLY	9	7008-052-199	FRONT PANEL
3	0124-031-000	#8-3/8" HEX WASHER HD SLOTTED SCREW	10	7008-051-199	BASE PANEL
4	7008-200-001	CONDENSOR ASSEMBLY	11	7003-250-000	TEMPERATURE CONTROL
5	0332-013-000	1" OD x 7/16" ID FLAT WASHER	12	7003-115-001	EVAPORATOR ASSEMBLY
6	7012-150-000	3/32" x 1-5/8" HITCH PIN	13	7012-030-001	220V COMPRESSOR ASSY
7	7012-051-000	RUBBER FOOT			