

A131.8-VR-BF4 Series
Barrier-Free, Vandal Resistant, Wall Mounted Chilled
Drinking Fountain w/ Sensor Activated Bottle Filler



** U.S. DESIGN PATENT D545,607 (Bowl Design)

A131408F-VR-BF4 / A131408S-VR-BF4

TECHNICAL ASSISTANCE TOLL FREE TELEPHONE NUMBER:
1.800.591.9360

Technical Assistance Fax: 1.626.855.4894

NOTES TO INSTALLER:

1. Please leave this documentation with the owner of the fixture when finished.
2. Please read this entire booklet before beginning the installation.
3. Check your installation for compliance with plumbing, electrical and other applicable codes.

LIMITED WARRANTY - UNITED STATES & CANADA

Murdock warrants that every cooler, bottle filling station, packaged water chiller, fountain and accessory to be free from defects in material and workmanship under normal use for one (1) year from date of install or eighteen (18) months after the date of shipment from the factory, whichever comes first.

Murdock warrants the compressor and hermetically sealed refrigeration system, including cooling coil assembly when part of the hermetically sealed refrigeration system, to be free from defects in material and workmanship under normal use for an additional four (4) years from the end of the one (1) year period described above.

This warranty does not cover installation or labor charges and does not apply to materials, which have been damaged by other causes such as mishandling or improper care or abnormal use. The repair or replacement of the defective materials shall constitute the sole remedy of the Buyer and the sole remedy of Murdock under this warranty. Murdock shall not be liable under any circumstances for incidental, consequential or direct charges caused by defects in the materials, or any delay in the repair or replacement thereof. This warranty is in lieu of all other warranties expressed or implied. Product maintenance instructions are issued with each unit and disregard or non-compliance with these instructions will constitute an abnormal use condition and void the warranty. Stainless steel must be protected on job site during construction and must be properly maintained after the water has been introduced into the water cooler or drinking fountain, or Murdock's limited warranty is void.

LIMITED EXPORT WARRANTY - One year on parts only.

Murdock assumes no responsibility for use of void or suspended data. © Copyright Murdock, City of Industry, CA Member of Morris Group International. Please visit www.murdockmfg.com for most current specifications.

COMPLIES WITH
STANDARDS



NSF/ANSI 61



Member of
MORRIS GROUP
INTERNATIONAL

MURDOCK
15125 Proctor Ave.
City of Industry, CA
91746 U.S.A.
Phone 800-591-9360
626-336-4561
Fax 626-855-4894
www.murdockmfg.com

IMPORTANT

This fixture is intended to dispense water that has been lowered in temperature, but otherwise remains unchanged by the materials in the drinking fountain. It is common for electrical equipment to be grounded to water lines either within a structure or away from it. Every attempt should be made to prevent this kind of grounding from generating electrical feedback into the drinking fountain creating electrolysis. Electrolysis will cause a metallic taste or cause water metal content to increase.

NOTICE

A dielectric coupling must be used to connect the drinking fountain to the water supply. A nonmetallic coupler is furnished with this water cooler to meet this requirement.

ROUGHING-IN AND DIMENSIONAL DRAWING

Prior to roughing consult with local, state, and federal codes for proper mounting height.

A131408S-VR-BF4 Refrigerated Wall Mounted Drinking Fountain

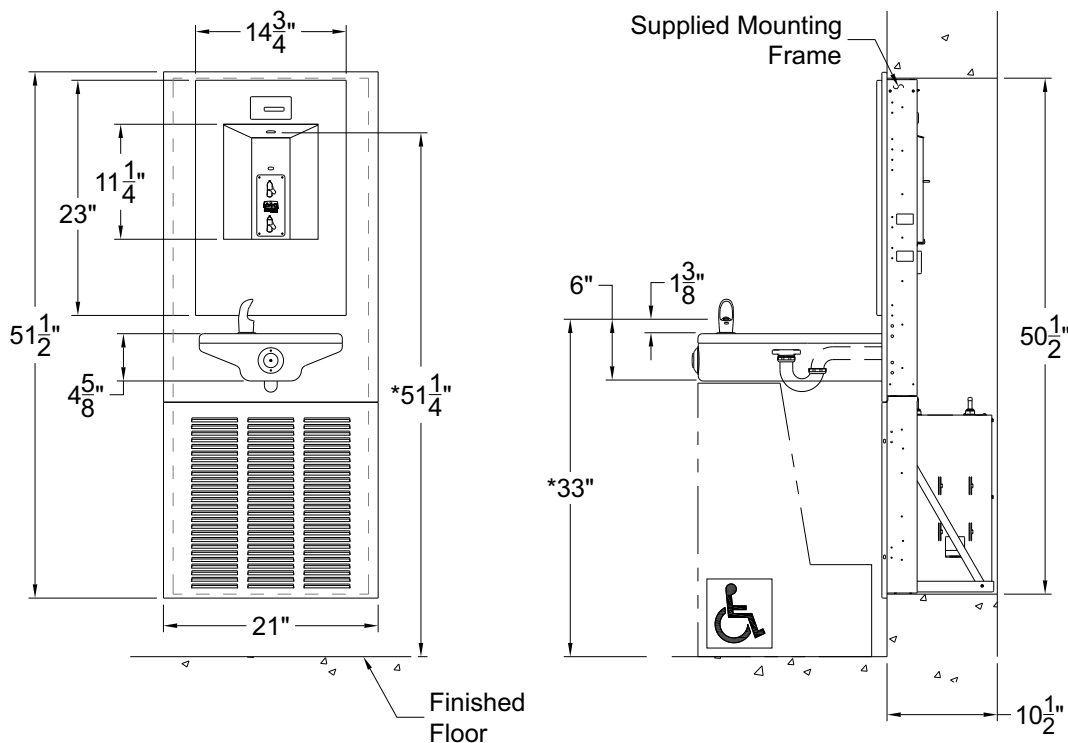

GENERAL NOTES:

1. ALL DIMENSIONS ARE IN INCHES [MM].
- *2. DIMENSIONS SHOWN ARE FOR RECOMMENDED ADULT HEIGHT. ADJUST VERTICAL DIMENSIONS AS NECESSARY TO COMPLY WITH FEDERAL, STATE & LOCAL CODES.
3. WATER LINE FROM CHILLER TO FOUNTAIN SHOULD BE COVERED WITH SPONGE FOAM RUBBER OR ICE WATER TYPE INSULATION OF ADEQUATE THICKNESS

NOTES: Dimensions shown for Adult ADA compliant installation. For Child ADA compliant parallel approach installation, decrease height of installation by 3 inches. Provide clear floor space as required. Adjust vertical dimensions as required to comply with federal, state, and local codes.

A131408S-VR-BF4 Refrigerated Wall Mounted Drinking Fountain Inlet & Outlet Rough-Ins

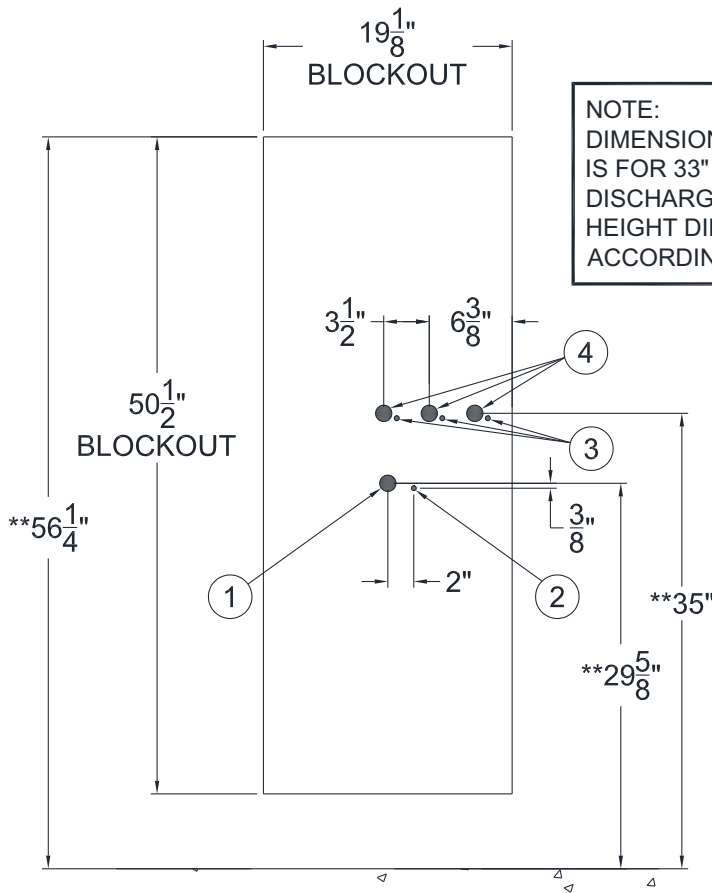
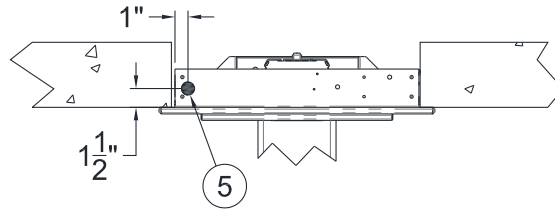

NOTE:
DIMENSION INDICATED WITH **
IS FOR 33" DRINKING FOUNTAIN
DISCHARGE HEIGHT. IF DISCHARGE
HEIGHT DIFFERS ADJUST
ACCORDINGLY.

- ① 1-1/4" O.D. DRINKING FOUNTAIN WASTE OUTLET
- ② 3/8" NCT DRINKING FOUNTAIN SUPPLY INLET
- ③ ALTERNATE 3/8" NCT BOTTLE FILLER SUPPLY INLETS
- ④ ALTERNATE 1-1/4" O.D. BOTTLE FILLER WASTE OUTLET
- ⑤ ELECTRICAL SERVICE ROUGH

DIMENSIONAL DRAWING

Prior to roughing consult with local, state, and federal codes for proper mounting height.

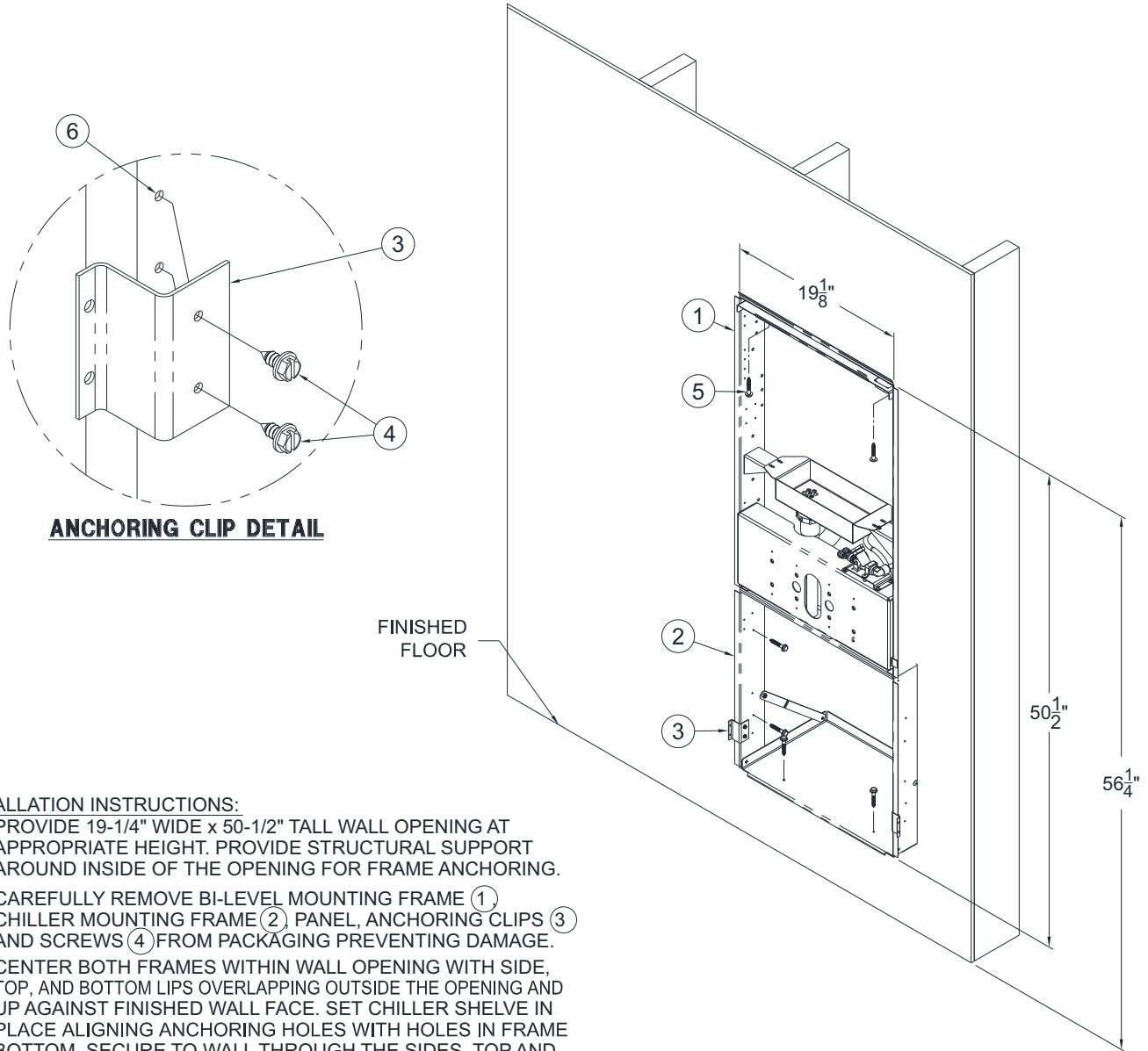

INSTALLATION INSTRUCTIONS:

- A- PROVIDE 19-1/4" WIDE x 50-1/2" TALL WALL OPENING AT APPROPRIATE HEIGHT. PROVIDE STRUCTURAL SUPPORT AROUND INSIDE OF THE OPENING FOR FRAME ANCHORING.
- B- CAREFULLY REMOVE BI-LEVEL MOUNTING FRAME (1) CHILLER MOUNTING FRAME (2) PANEL, ANCHORING CLIPS (3) AND SCREWS (4) FROM PACKAGING PREVENTING DAMAGE.
- C- CENTER BOTH FRAMES WITHIN WALL OPENING WITH SIDE, TOP, AND BOTTOM LIPS OVERLAPPING OUTSIDE THE OPENING AND UP AGAINST FINISHED WALL FACE. SET CHILLER SHELVES IN PLACE ALIGNING ANCHORING HOLES WITH HOLES IN FRAME BOTTOM. SECURE TO WALL THROUGH THE SIDES, TOP AND BOTTOM USING HARDWARE (5) BY OTHERS ENSURING 16" CENTERLINE DIMENSION LEFT-TO-RIGHT.
- D- INSTALL TWO ANCHORING CLIPS (3) AT BOTTOM ON OUTER SIDES OF CHILLER MOUNTING FRAME (2) ALIGN HOLES IN CLIPS WITH HOLES (6) FRAME AND USE SHEET METAL SCREWS (4) PROVIDED. SEE ANCHORING CLIP DETAIL.

IMPORTANT:

1. Water Supply Service Stop Valve, Water Connections and Electrical Connections to be supplied by others in accordance with local codes.
2. Provide 4" minimum clear space in front of bottom trim panel and above in-wall chiller to allow for proper ventilation.
3. Waste is 1-1/4" Outer Diameter. Chiller water inlet is 3/8" Outer Diameter copper tube. Chiller water outlet is 3/8" Outer Diameter copper tube. Drinking Fountain water inlet is 3/8" Outer Diameter copper tube. Bottle Filler water inlet is 3/8" Outer Diameter copper tube. Water line by others from in-wall chiller to drinking fountain must have adequate insulation.
4. Completely flush supply lines of all foreign debris before connecting to fixture. Water cooler designed to not cause problems with taste, odor, color, or sediment. Optional water filter (Wf1), is available should any of these problems arise from the water supply.
5. Do NOT solder tubes inserted into the chiller, bottle filler or the fountain strainer as damage to the o-rings on the push-in fittings may result.
6. All burrs must be removed from outside of cut tubes before inserting into strainer or other components.
7. Power supply must be identical in voltage, cycle and phase to that specified on the chiller data plate. Refer to submittal.
8. This unit must be grounded per the requirements of applicable electrical codes.
9. **WARNING:** Warranty is voided if installation is not made following current Acorn Engineering installation instructions and if components are assembled to the fixture that are not approved by Acorn Engineering.
10. Fixture operates within water pressure range of 174 kPa (25 psig) to 724 kPa (105 psig). Acorn Engineering will not warranty chiller damaged when connected to supply lines with flow pressure lower than 174 kPa (25 psig) or higher than 724 kPa (105 psig). A pressure regulator must be furnished by others on supply line if inlet pressure is greater than 724 kPa (105 psig).
11. Due to cold waste water, Acorn Engineering recommends that waste piping supplied by installer be insulated appropriately to prevent excessive condensation.
12. *Per UPC 609.10-All building water supply systems in which quick acting valves are installed shall be provided with devices to absorb the hammer caused by high pressure resulting from the quick closing of the valve. These pressure-absorbing devices shall be approved mechanical devices. Water pressure-absorbing devices shall be installed as close as possible to the quick closing valve.*

PRIOR TO INSTALLATION:

1. Read all installation instructions carefully, before proceeding.
2. Carefully remove all fixture components from packaging, preventing scratching or damage. Inspect fixture and all parts from damages and all parts are bolted on.
3. Provide mounting surface, sufficient to support the fixture and loads on the fixture.
4. Provide rough-ins as shown on the roughing-in and dimensional drawing, including water supply, drain pipe and gravel drain well. (See rough-in details)
5. It is common for electrical equipment to be grounded to water lines either within a structure or away otherwise remains unchanged by the materials in the water cooler. Every attempt should be made to prevent this kind of grounding from generating feedback into the water cooler creating electrolysis. Electrolysis will cause a metallic taste or cause water content to increase.
6. Receptacle(s) must be wired to a GFCI protected circuit. Fixture must be earth grounded per NEC (National Electrical Code).
7. Completely flush water supply lines of all foreign debris, before connecting to the fixture.

DRINKING FOUNTAIN INSTALLATION:

1. Insert mounting frame into the rough-in block out and secure using 1/4"-20 UNC mounting hardware (Provided by Others).
2. Place the Chiller Unit onto the basepan of the frame assembly.
3. Hang upper trim panel on mounting frame. Note: The included 1" brackets do not get used with this installation and the plastic spacers are typically not required and can be discarded.
4. Install the four threaded studs into the Wall Mounting Frame
5. Remove the drinking fountain top by taking out the drain screw and lifting at the front while pulling forward. Disconnect bubbler tube. Set top aside in a safe place where it will not be damaged. Place the screw in a secure location where it will not be lost.
6. Slide Fixture over studs and secure with nuts and washers.
7. Assemble P-trap to drain adapter and then assemble to unit with Phillips screws.
8. Make-up 1-1/4" outer diameter waste connection.
9. After thoroughly flushing the 3/8" outer diameter supply line, connect water supply to in-wall chiller and provide connection from chiller to the multi-line "Y" strainer assembly. From multi-line "Y" strainer assembly, connect to drinking fountain bubbler.
10. Place drain gasket on drain adapter. Reconnect bubbler tube. Reassemble top to unit by engaging back clip and securing with screw.

BOTTLE FILLER INSTALLATION:

1. With drinking fountain installed, connect water supply line from multi-line "Y" strainer assembly to bottle filler.
2. Loosen slip nuts to orientate P-trap to desired direction then tighten slip nuts and make up 1-1/4" O.D. waste connection.
3. **FOR -BF4 ONLY** Make up power connections to the ground, neutral & hot within the electrical box.

NOTE: BEFORE PERFORMING STEP 4 REFER TO ELECTRICAL INSTALLATION.

4. Test for leaks and proper operation, and then install the bottle filler panel using the water filler bracket and secure the bottle filler by tightening the screws under the bottle filler.

DRINKING FOUNTAIN START UP:

1. Before connecting power supply, but after thoroughly flushing the supply line and connecting it to the cooler, turn on building water supply and check all connections for leaks.
2. Air within the drinking fountain system or the structure supply piping will cause an irregular bubbler outlet stream until purged out by incoming water. Covering the bubbler with a clean cup (or similar object) is recommended when first activating drinking fountain to prevent excessive splashing.
3. Depress front push pad until steady water stream is achieved.
4. If water flow requires adjustment, insert a slotted narrow blade screwdriver in the hole centered on the underside of the fixture in the knee clearance area up to the flow regulator. Turning clockwise will increase flow and turning counterclockwise will decrease flow.
5. Recheck all water connections with water flowing through system.
6. With power still NOT connected, carefully manually rotate cooling fan to ensure proper clearance and free fan action
7. Provide power to water chiller and make sure unit begins to function.
8. Assemble louvered bottom trim panel with screws provided to brackets on either side of wall mounting frame.

BOTTLE FILLER START UP:

1. Air within the bottle filler system or the structure supply piping will cause an irregular spout outlet stream until purged out by incoming water. Press and hold pushbutton until steady water stream is achieved.
 - **SENSOR OPERATED:** Hold container to be filled just below the sensor in the center of the filler spout and then move the container upward and water flow will start automatically. When the container is almost filled, lower the container below the sensor until the water stops flowing. (See label on the bottle filler.

WATER TUBING CONNECTIONS:

NOTE: Insulation on all water tubes not shown (all PE water tubes are insulated).

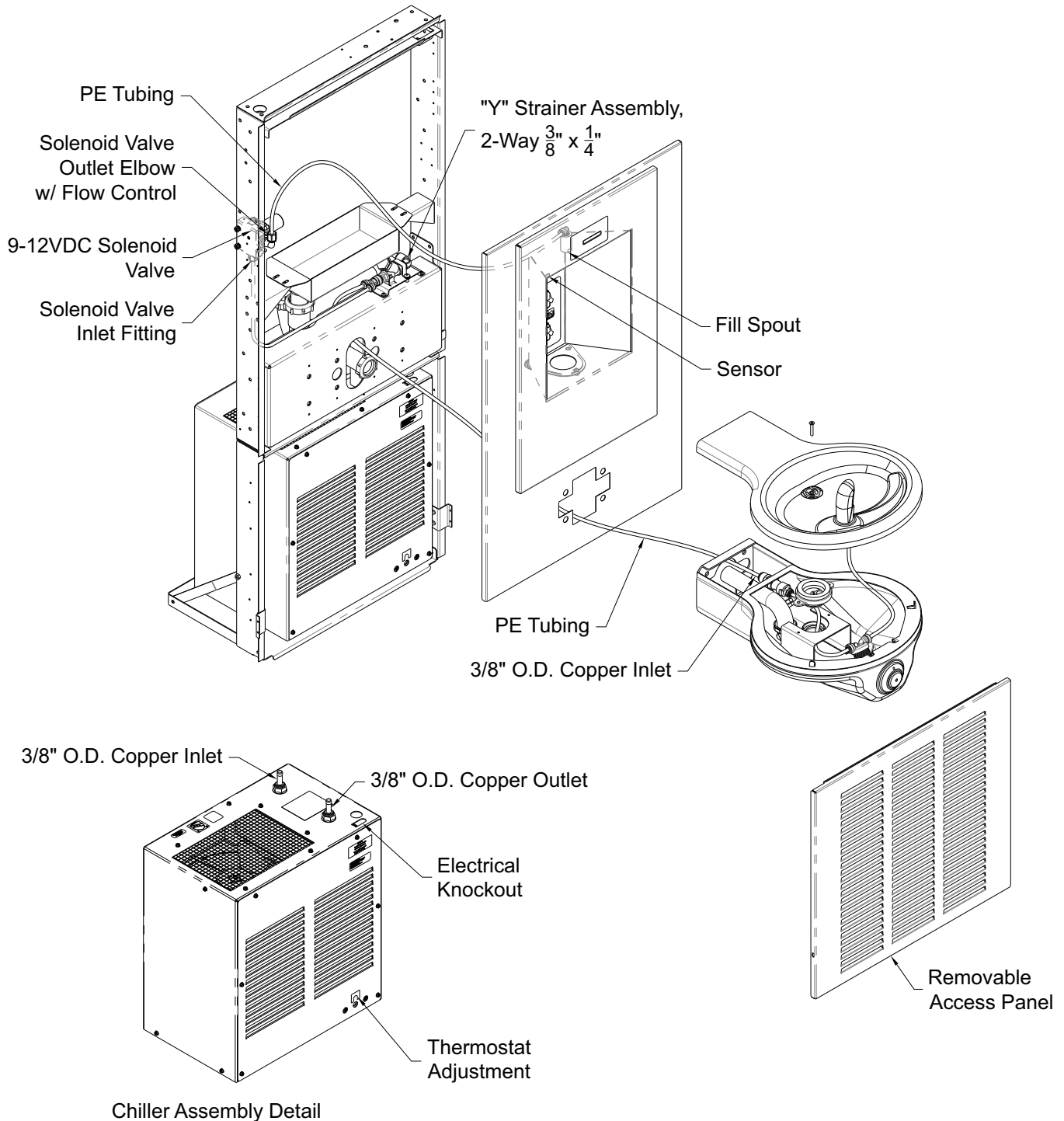

OPTIONAL -WF1 WATER FILTER

Page for models with -WF1 Water Filter (A131.8-BF4-WF1)

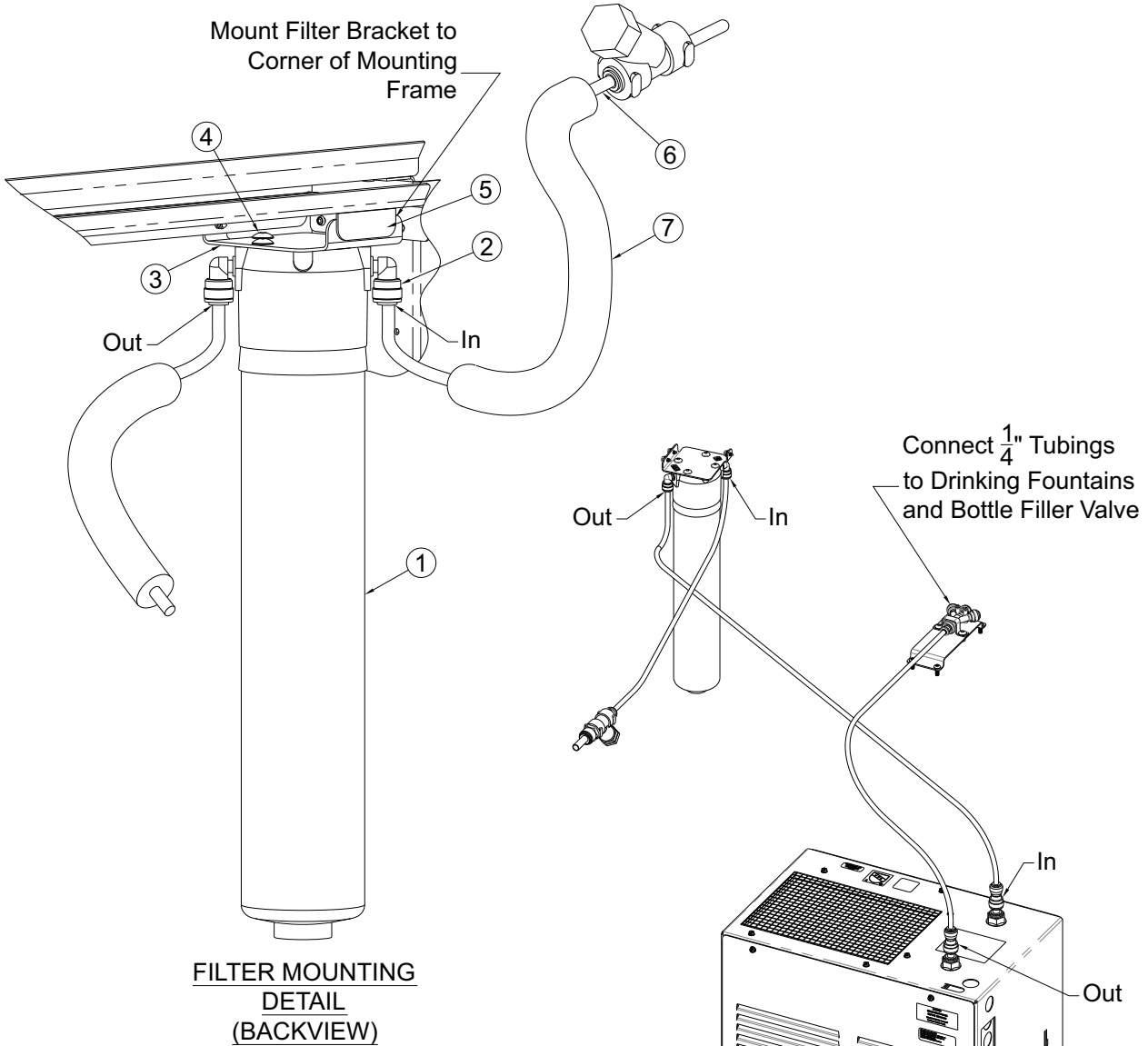

ITEM	PART NUMBER	DESCRIPTION
1	0250-006-000	#10 x 5/8" Phillips Truss Head Screw
2	7014-035-199	Water Filter Bracket
3	0124-031-000	#8 x 3/8" Hex Washer Head Screw
4	1895-709-000	Elbow, 1/4" Push-In x 1/4" Stem
5	7012-311-000	WF1 Filter 1500 Gallon
6	2169-000-000	Tubing, 1/4" O.D. LLDPE, (Blue)
7	7012-055-000	Foam Pipe Insulation

OPTIONAL -WF1 WATER FILTER INSTALLATION

FILTER CARTRIDGE REPLACEMENT:

1. Remove panel assembly, this allows access to the filter and the inlet valve (provided by others). Turn valve knob 1/4 turn clockwise to close.
2. With the filter assembly secured on the unit, hold the cap firmly, turn the replaceable cartridge filter counterclockwise to remove.
3. Remove and replace the cartridge turning clockwise to secure.
4. Turn inlet 1/4 turn knob 1/4 turn counterclockwise to open and test for leaks and proper operation before remounting panel assembly to fixture.

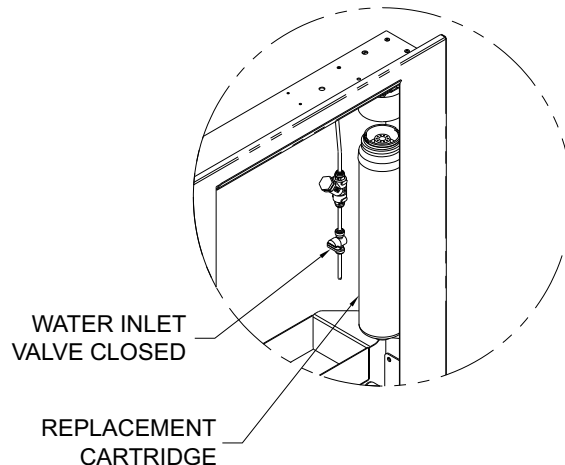
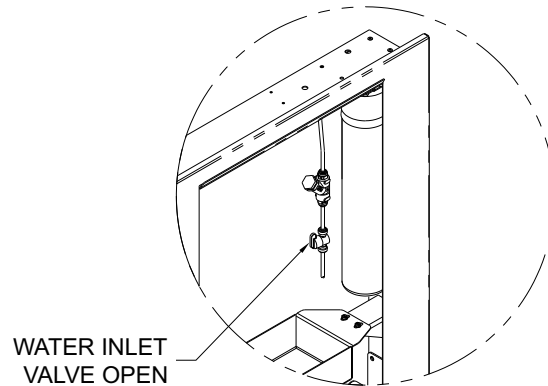
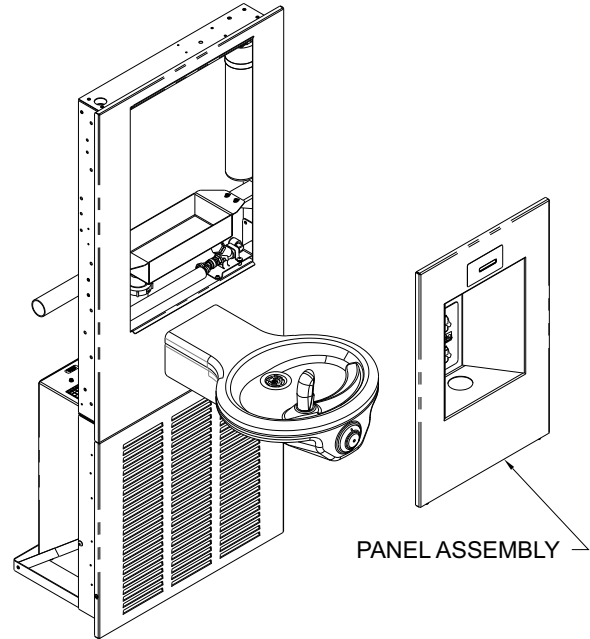

ELECTRICAL INSTALLATION:

NOTE: Plug in power is a standard feature.

1A. Plug-In Operation: Plug transformer provided into GFCI protected electrical service, used by the semi-recessed bottle filler. Plug in transformer to power supply and connect to red sensor wire.

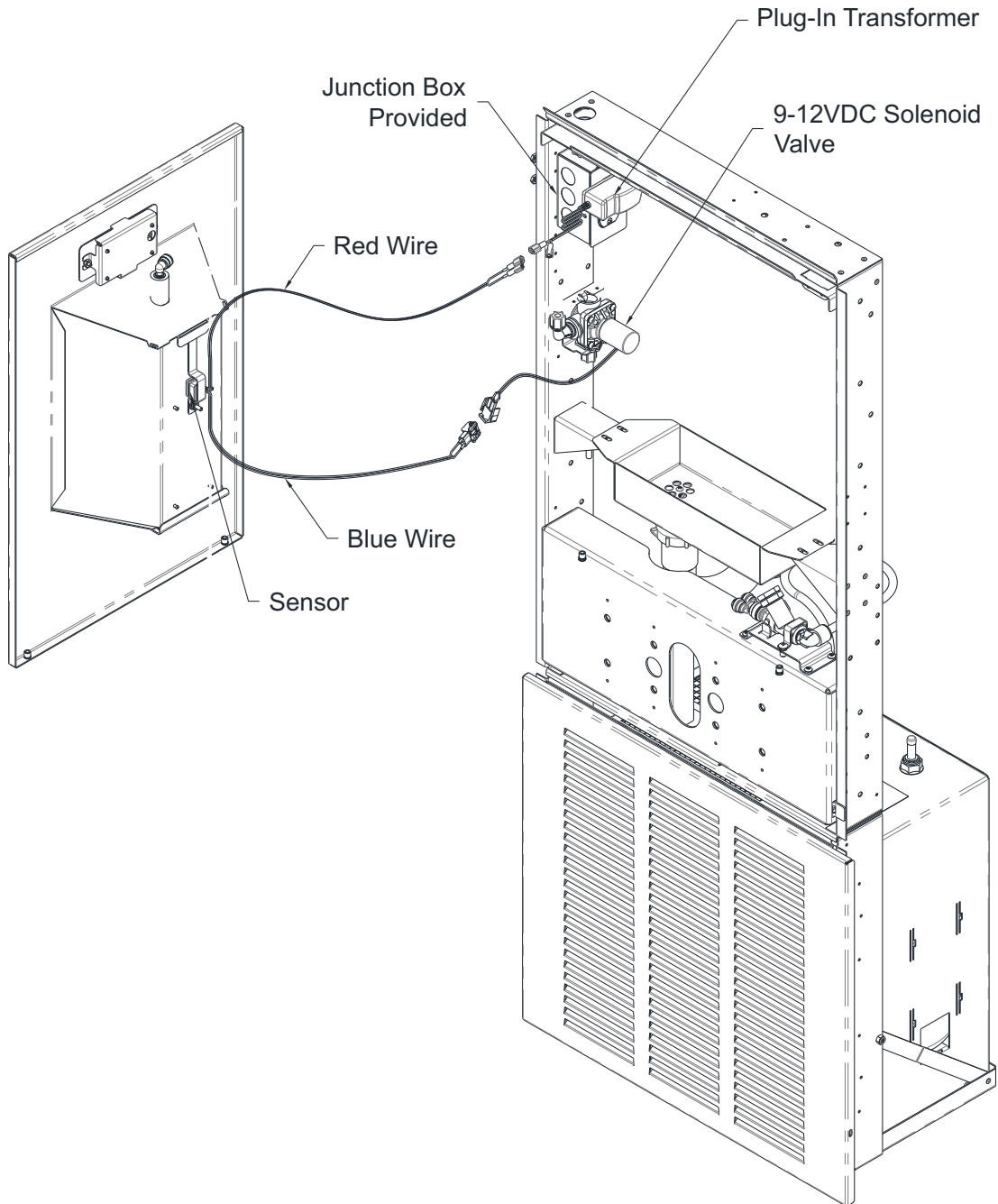

OPTIONAL -BCD BOTTLE COUNTER DISPLAY

BOTTLE COUNTER ADJUSTING & RESETTING INSTRUCTIONS:

NOTE: Bottle Counter Has Multiple Functions

Reset/ Mode Button

- Counts refilled bottles, otherwise purchased
- Adjustable for Units with and without filters
- “REPLACEMENT FILTER” alert function
- Alert reset, when filter is replaced

Description

Illuminated LCD display, counts bottles, and has a filter replacement alert function

Bottle Counting Function

The software applies a flow volume of approximately 16.9 fl oz (volume in standard size plastic water bottle) to each bottle counted. If the flow volume is less than 16.9 fl oz there will be no count but the volume will accumulate, so that part way through the next cycle the total bottle count will change.

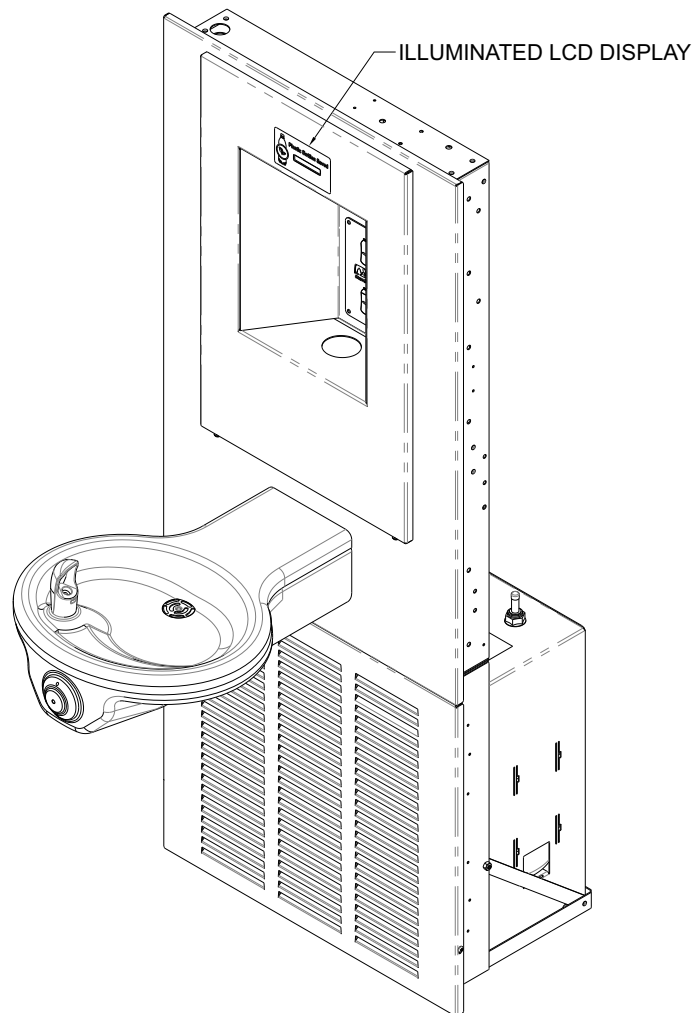

OPTIONAL -BCD BOTTLE COUNTER DISPLAY

FILTER REPLACEMENT FUNCTIONS:

NOTE: When the volume accumulates to 1500 gallons (recommended maximum filter flow volume) the “REPLACE FILTER” alert will appear on the display every time the bottle filler is activated.

Counter Modes

Located on the back of the display you will find the reset button for the mode settings. The Reset/Mode selection button is accessible by removing the bottle filler panel assembly, then locate the large hole in the back of the display mounting bracket. Use your finger or nonconductive implement to depress the Reset/Mode Selection Button.

!!!DO NOT USE SHARP OR METAL IMPLEMENTS!!!

With this reset button, you are able to indicate whether or not the unit has a filter or does not have a filter. The reset button will also take away the “REPLACE FILTER” alert once the filter has been replaced.

Systems With or Without Filter

- Depress the Reset/Mode selection button for 6 Seconds, the number of seconds will count up on the display.
- At the end of the 6 seconds, “FLTR YES” or “FLTR NO” **WILL APPEAR** on the display.
- “FLTR YES” means that there is a filter in the system and a “REPLACE FILTER” alert **WILL APPEAR** on the display when the maximum filter flow volume is reached.
- “FLTR NO” means that there is no filter in the system and a “REPLACE FILTER” alert **WILL NOT APPEAR** on the display.
- Release button when the option required is on the display (Filter Yes or No)

CLEARING “REPLACE FILTER” ALERT:

NOTE: This Function only applies if the system as a filter

- Replace old filter with new filter.
- Depress the Reset/Mode selection button for **2 SECONDS**
- The “REPLACE FILTER” will no longer appear on the display
- Test by actuating the bottle filler, alert will not appear.

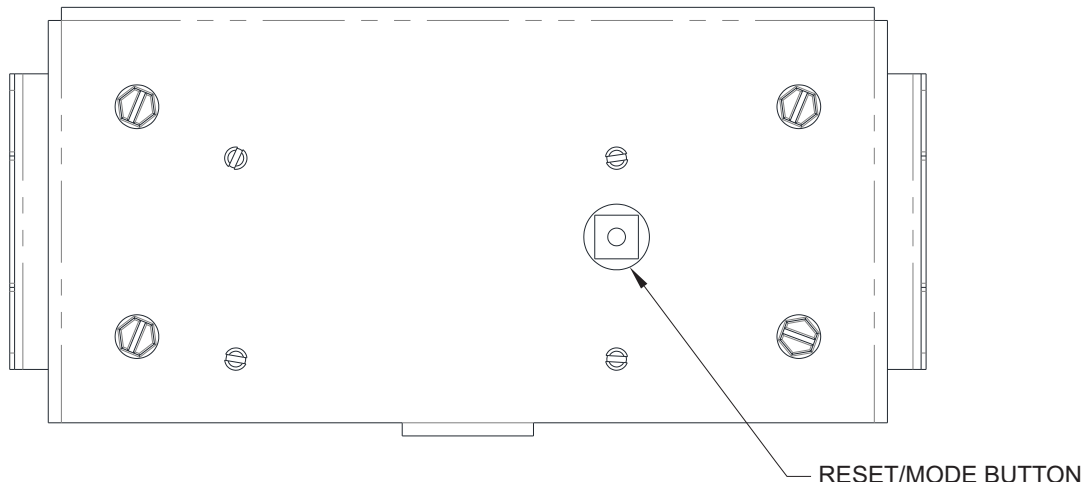

OPTIONAL -BCD BOTTLE COUNTER DISPLAY

BOTTLE FILLER & BOTTLE COUNTER CONNECTIONS:

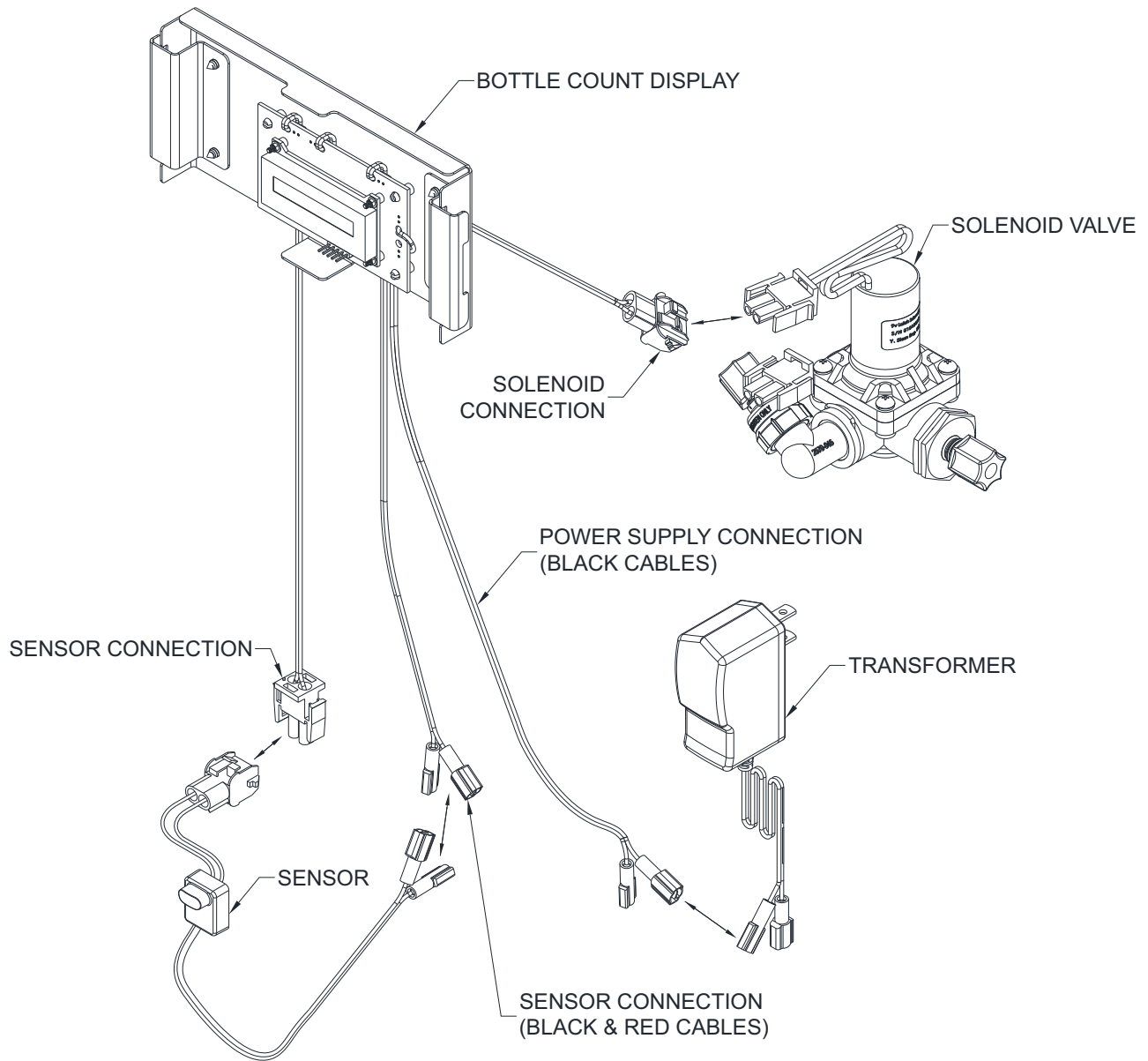

PUSH-IN FITTING INSTALLATION

NOTE: FITTINGS AND TUBE SHOULD BE KEPT CLEAN, BAGGED AND UNDEAMAGED PRIOR TO INSTALLATION.

TO CUT TUBE:

Cut to fit length of 1/4" PE tubing and remove any burrs or sharp edges. Ensure that the outside diameter is free from score marks. Tube ends should be square.

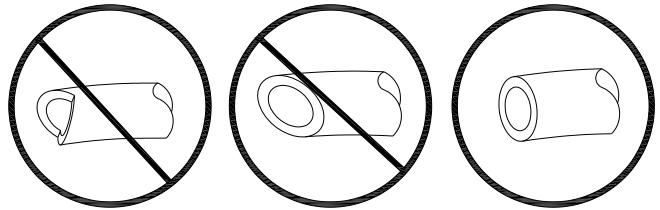

INSERTING THE TUBE:

1. Firmly and fully insert the tubing end into the push-in fitting up to the tube stop located approximately 1/2" deep.

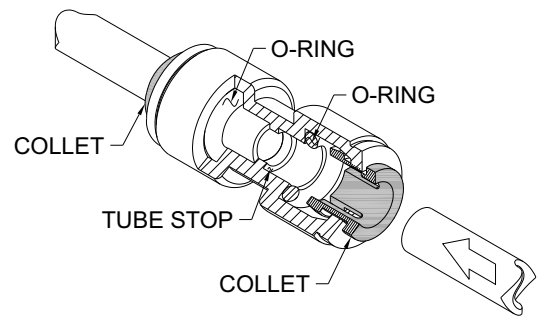

2. Pull on the fitted tubing to ensure it is secure. Tube should not come free from the fitting. Water test the connection assembly prior to leaving the site to ensure there are no leaks.

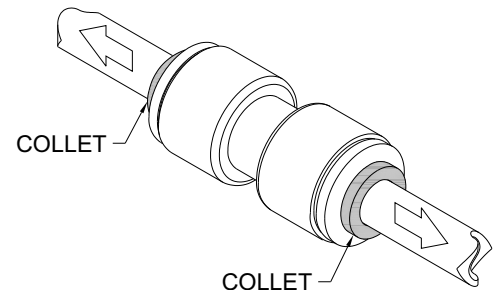

DISCONNECTING THE TUBE:

To disconnect the tube from the fitting ensure that the water line is depressurized. Push collet square towards the push-in fitting body and hold. While holding the collet in, pull on the PE tubing to remove from the push-in fitting.

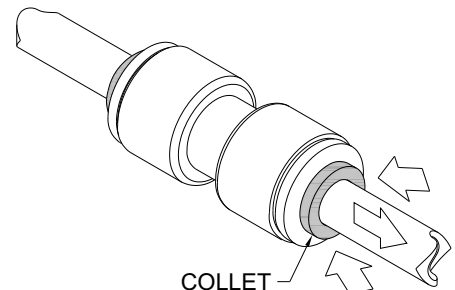

TROUBLE SHOOTING:

IMPORTANT: BEFORE MAKING ANY OF THE REPAIRS LISTED, MAKE SURE THE WATER CHILLER IS DISCONNECTED FROM THE ELECTRICAL SUPPLY AND THE WATER SUPPLY VALVE IS SHUT OFF.

1. ADJUSTMENTS:

- a. Cartridge – The water flow can be adjusted using a slotted narrow blade screwdriver and turning clockwise to increase flow and counterclockwise to decrease flow.
- b. Cold Water Thermostat – The water temperature can be adjusted using a slotted screwdriver and turning clockwise to make colder and counterclockwise to make warmer.
- c. Bubbler Stream - Bubbler can be rotated slightly to direct the stream backwards or forwards. Adjust the stream to minimize splashing. Splashing may occur from bubbler stream if the unit is not level. Shim lower mounting point, if necessary, to level chiller.

2. COMPRESSOR DOES NOT RUN:

- a. Check the electrical supply for power and correct voltage. The incoming voltage must be within 10% of the rated voltage on the serial nameplate.
- b. If the cold thermostat capillary bulb loses its charge or becomes kinked it will fail in the open position causing a disruption of power to the compressor. Disconnect electrical supply to the water chiller and using an ohm meter check for continuity across the two electrical terminals on the thermostat. Install a new thermostat if there is no continuity.
- c. Check for loose wires within the compressor box. The incoming power leads must be connected to the overload and relay.
- d. If all components check positive for continuity then test the wiring harness plug for continuity to see if there is a broken wire within the wiring harness insulation.

3. COMPRESSOR RUNS - WATER IS WARM:

- a. The most common cause for a water chiller to run without producing cold water is a loss of refrigerant. The water chiller must be taken to a certified refrigerant technician for repairs.
- b. Make sure the condenser fan motor is operative. The fan blade must turn freely to help remove the heat of compression.
- c. An incorrect refrigerant charge, restriction or defective compressor (not pumping) will also cause the compressor to run without producing cold water. All these signs indicate a problem within the refrigeration system and the water chiller must be checked by an authorized service company.

4. COMPRESSOR CYCLING ON OVERLOAD PROTECTOR:

- a. A dirty condenser or a blocked fan will cause a high head pressure and frequent cycling of the overload protector.
- b. Check the incoming voltage to make sure it is within 10% of the serial nameplate rating.
- c. A restriction or moisture in the system will also cause intermittent cycling. A certified refrigeration mechanic should be contacted in this situation.
- d. Change the overload or relay if defective.

5. NOISY OPERATION:

- a. Check to make sure the fan blade is rotating freely.
- b. Check the compressor mounting to make sure the pins and clips are not rattling. If the compressor appears to be noisy internally, it must be replaced.

6. RESTRICTED OR NO WATER FLOW:

- a. Ensure water supply service stop valve is fully open.
- b. Verify minimum 20 psig supply line flow pressure.
- c. Check for twists or kinks in outlet tubing.
- d. Check the water inlet "Y" strainer. Sediment from the main supply can get trapped in the screen along with installation materials such as pipe dope and flux. The screen should be cleaned and checked on a regular basis and replace if needed.
- e. The cartridge valve located in the water control assembly or bubbler can also become clogged with foreign material. The cartridge valve can only be replaced and not repaired.
- f. Check flow adjustment. See start up note #3.
- g. Flow control in solenoid valve outlet elbow clogged remove & clean.

- h. The water chiller may also develop a freezing condition in which the water will become frozen inside the evaporator coil. This indicates a refrigeration problem or thermostat failure in which case the water chiller needs to be checked by a qualified technician.
- i. No power to transformer connections, loose or wires cut.

7. WATER DRIPS OR WILL NOT SHUT OFF:

- a. Open fixture. Loosen nuts holding valve bracket assembly to bottom of fixture but do not remove. Move complete valve bracket assembly further back from the front push pad and tighten to lock in place.
- b. Replace valve cartridge.

SENSOR TROUBLE SHOOTING:

8. IF LIGHT WITHIN SENSOR DOES NOT FLASH ONCE WHEN USER IS WITHIN RANGE:

- a. Verify 120VAC input & 9VDC output transformer output 9VDC.
- b. Replace defective transformer.
- c. Transformer polarity crossed. Replace transformer, sensor may be damaged and also need replacement.
- d. Sensor in "Security Mode" after 30 seconds of consistent detection. Remove source of detection and wait 30 seconds before checking.
- e. Sensor is picking up a highly reflective surface. Eliminate cause of reflection and wait 30 seconds before checking.

9. IF LIGHT WITHIN SENSOR LENS FLASHES ONCE WHEN THE USER IS WITHIN RANGE:

- a. Repair bad connection from sensor to solenoid.
- b. There is debris or scale in the solenoid assembly. Remove solenoid, pull out plunger and spring. Clean with scale remover solution.
- c. There is debris or scale in the center or two holes in convolution of the water diaphragm. Remove and clean.

CLEANING & MAINTENANCE GUIDE:

- 1. Motors have lifetime lubrication and do not require scheduled maintenance.
- 2. Excess dirt or poor ventilation will cause the compressor overload protector to turn the compressor off and it will cycle on and off with no cold water coming out of bubbler. Periodically clean with vacuum cleaner, air hose or brush the condenser fins and cabinet ventilation louvers. In environments where dirt and dust is more prevalent, clean more frequently.
- 3. Periodically remove fountain top and clean out in-line strainer.
- 4. Periodically remove access panel of cooler and clean out inline "Y" strainer

For Powder coated units: Units should be cleaned using a mild soap solution with a sponge or cotton cloth. Wipe down surfaces then rinse with clean water.

For Stainless steel units:

- 1. To Remove water spots or rust spots, stainless steel cleaner/polish on a cloth is recommended.
- 2. If there are stubborn spots or if you wish to treat a scratch, synthetic abrasive general purpose pads such as scotch brite are recommended.
- 3. Apply stainless steel cleaner/ polish to the synthetic abrasive pads and carefully rub the panel with the grain.
- 4. DO NOT use harsh chemicals, abrasive or petroleum based cleaners. Use of these will void the Acorn warranty. DO NOT use abrasives on powder coated units.
- 5. Stainless steel should be kept clean at all times. If a coating of stainless steel cleaner/ polish is maintained, stainless steel surfaces will retain their new, clean, polished appearance indefinitely.

FOUNTAIN PARTS BREAKDOWN

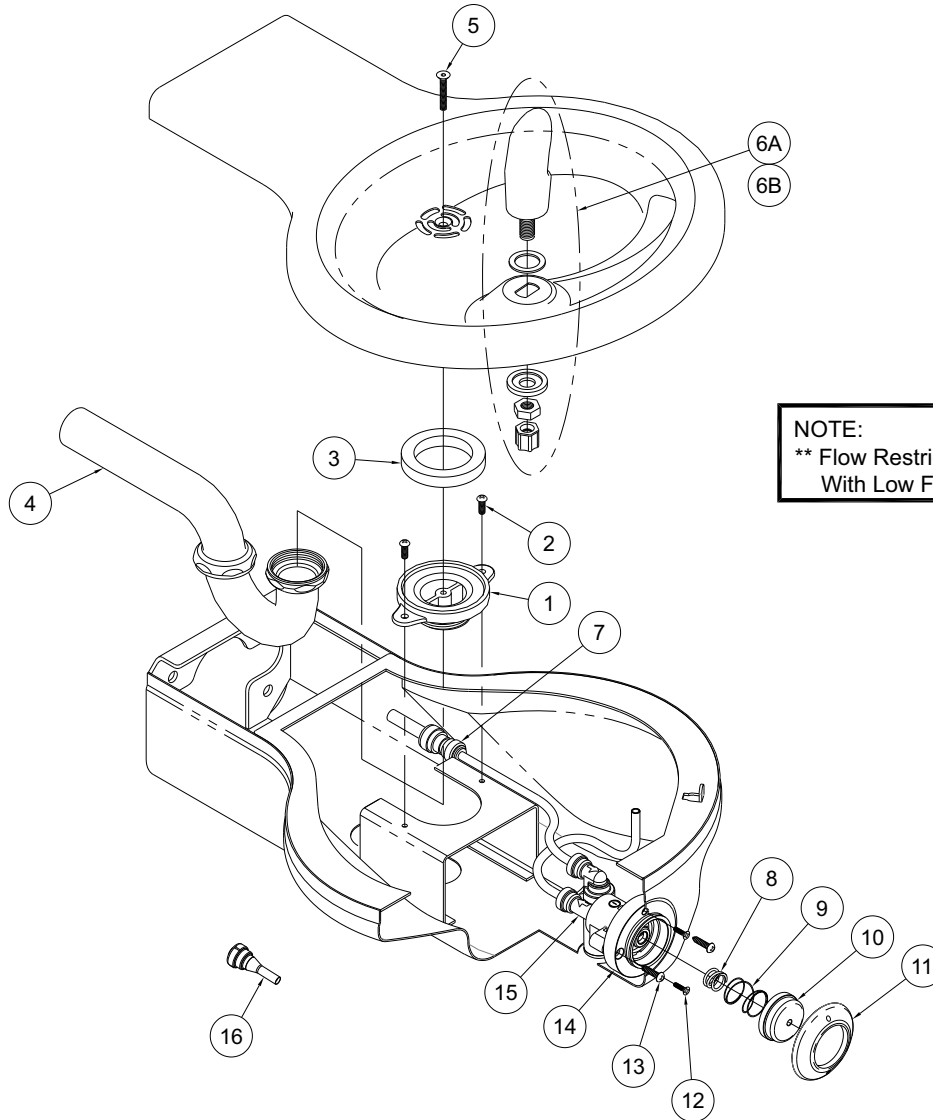

NOTE:
** Flow Restrictor Only Available
With Low Flow Bubbler.

ITEM #	PART NUMBER	DESCRIPTION	ITEM #	PART NUMBER	DESCRIPTION
1	7000-005-199	Drain Adapter	9	7003-193-000	Spring, Pushbutton Return
2	0116-016-000	#10-32 x 3/8" Phillips Truss Head Screw	10	7003-196-199	Pushbutton, Chrome
3	7000-006-000	Flat Drain Adapter Gasket	11	7003-197-199	Escutcheon, Chrome
4	7000-015-000	1-1/4" OD P-Trap	12	0161-062-000	#6-32 x 1/2" Phillips, Flat Head Screw
5	0152-010-000	#10-32 x 1" Hex Flat Head Screw	13	0124-055-000	#8 x 3/4" Phillips, Round Head Screw
6A	7000-012-001	Stainless Steel Bubbler Assembly	14	7003-198-199	Mounting Sleeve
6B	7000-099-002	Flexible Gray Bubbler Assembly	15	7003-095-001	Valve Body Sub Assembly
7	1895-123-000	1/4" x 3/8" OD Tube Union Push-In	16	7003-093-001	Flow Restrictor - Low-Flow Bubbler Only
8	7003-195-000	Spring, Overtravel			

Repairs must be made with Murdock Manufacturing parts only. Please order through your local representative or distributor. The phone number to locate your local representative is 1.800.591.9360.

A131.8-VR-BF4 SERIES BREAKDOWN

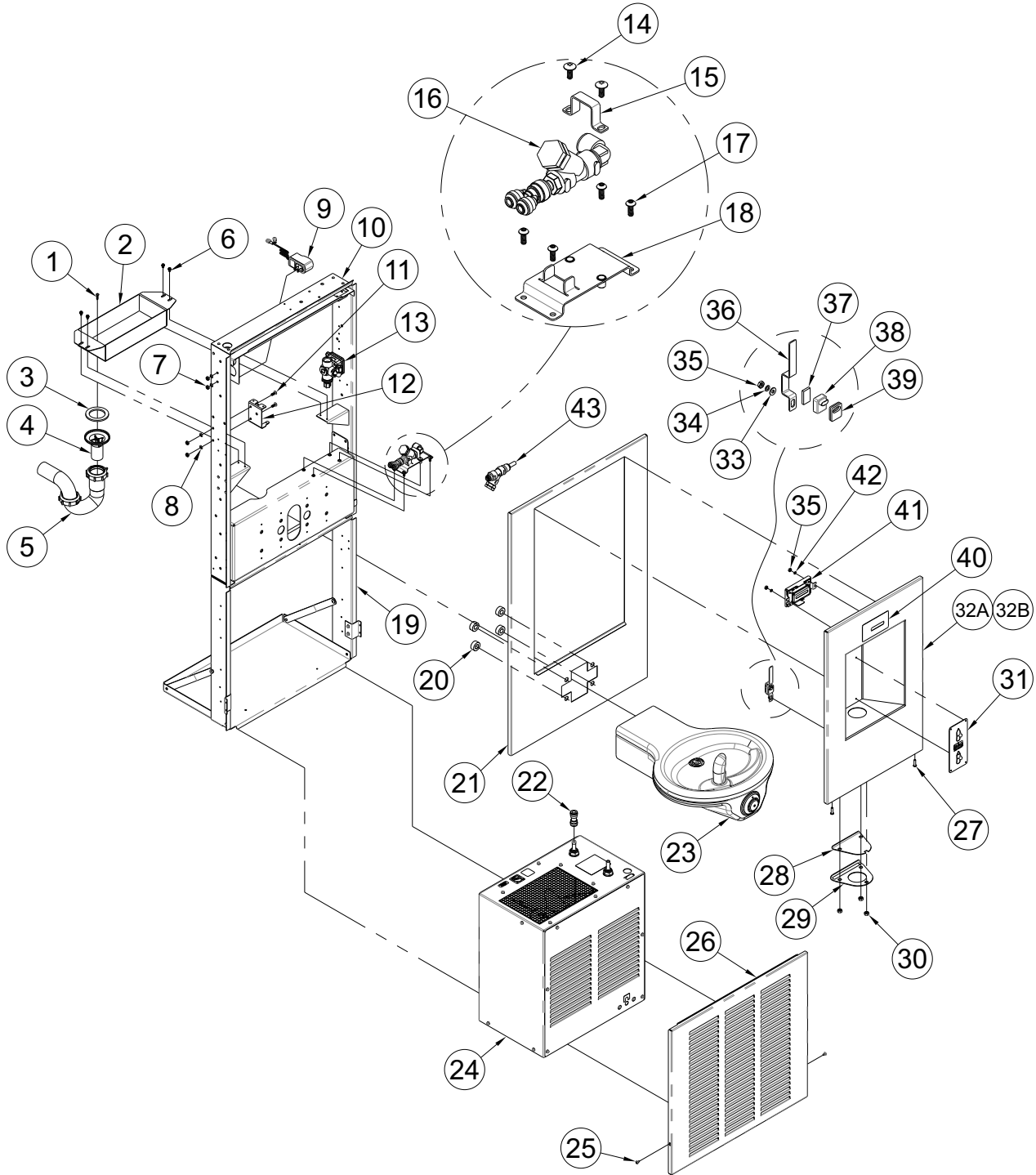

Repairs must be made with Murdock Manufacturing parts only. Please order through your local representative or distributor. The phone number to locate your local representative is 1.800.591.9360.

A131.8-VR-BF4 SERIES BREAKDOWN

ITEM#	PART NUMBER	DESCRIPTION
1	0110-004-000	#8 x 3/4" Phillip Pan Head Screw
2	7014-034-199	Drain Tray, -BF4
3	7000-006-000	Drain Adapter Gasket
4	7003-186-199	1-1/4" x 2-3/4": Plastic Drain Tube
5	4970-265-000	1-1/4" P-Trap
6	0124-031-000	#8-3/8" Hex Head Screw
7	0302-004-000	#10-32 S/S Hex Nut
8	0321-011-000	#10 S/S External Tooth Lockwasher
9	0710-730-001	9V Plug-In Transformer
10	7014-160-001	Mounting Frame Assembly, BF4
11	6502-070-000	#10-32 x 1/2" Pan Head Screw
12	7014-036-199	Solenoid Mounting Bracket
13	7013-133-001	Valve Assembly
14	0116-010-000	#10-32 x 1/2" S/S Phillips Truss Head Screw
15	7013-232-199	"Y" 2-Way Divider Bracket Clamp
16	7013-220-001	"Y" 2-Way Divider Assembly, BF4
17	0112-021-000	#10-32 x 1/2" S/S Hex Screw
18	7013-221-199	Bracket "Y" Strainer Mount
19	7014-140-001	Frame, Chiller Mount, BF4
20	7000-245-000	Back Panel Spacer
21	7014-167-199	Upper Trim Panel, #4 Finish, BF4
22	1895-123-000	1/4" x 3/8" O.D. Tube Union Push-In
23	Drinking Fountain	See Drinking Fountain Repair Parts for components
24	7008-010-001	8GPH Chiller Assembly
25	0124-051-000	#8 x 3/8" Allen Pan Head
26	7000-238-199	Vented Panel, #4 Finish
27	0116-013-000	#10-32 x 3/4" Phillips Round Head Screw
28	7013-103-199	Mesh Screen
29	7013-114-199	Screen Plate -BF4
30	0302-005-000	1/4-20 UNC S/S Hex Nut
31	7013-032-000	Graphics Plate, #4 Finish
32A	7014-019-003	Bottle Filler Panel Assembly, Less BCD, #4 Finish
*32B	7014-020-003	Bottle Filler Panel Assembly, BF4-BCD, #4 Finish
33	0331-023-000	#8 S/S Flat Washer
34	6527-108-000	#8 Internal Tooth Lockwasher
35	0302-003-000	#8-32 S/S Hex Nut
36	7013-014-199	Nano Sensor Bracket
37	7013-019-199	Foam Tape
38	2563-380-001	Nano Sensor Assembly
39	7013-009-001	Nano Sensor Spacer Assembly
*40	7013-034-000	Nameplate, Outdoor Bottle Filler (Green)
*41	7014-022-001	BCD, Bottle Filler Counter Bracket Assembly
*42	0331-003-000	#8 Helical Spring Lock Washer
43	7000-021-001	"Y"-Strainer Assembly, 1/4"

NOTE:

Items with (*) are for units
with -BCD option only.

Repairs must be made with Murdock Manufacturing parts only. Please order through your local representative or distributor. The phone number to locate your local representative is 1.800.591.9360.