

Location: _____



F1580

24" X 24" HEAVY DUTY DEEP SUMP DRAIN WITH BOTTOM OUTLET

Specification: MIFAB® Series F1580 powder epoxy coated deep sump drain with secondary dome strainer, bottom outlet and extra heavy duty 24" x 24" (610 x 610) two section ductile iron grates with a free area of 200 square inches (129,032²). Grates to have maximum 13/16" (21) openings.

Function: Used in industrial factories, mechanical rooms, parking garages and other membrane finished areas. 24" x 24" tractor grate is used with all types of poured finished floors.

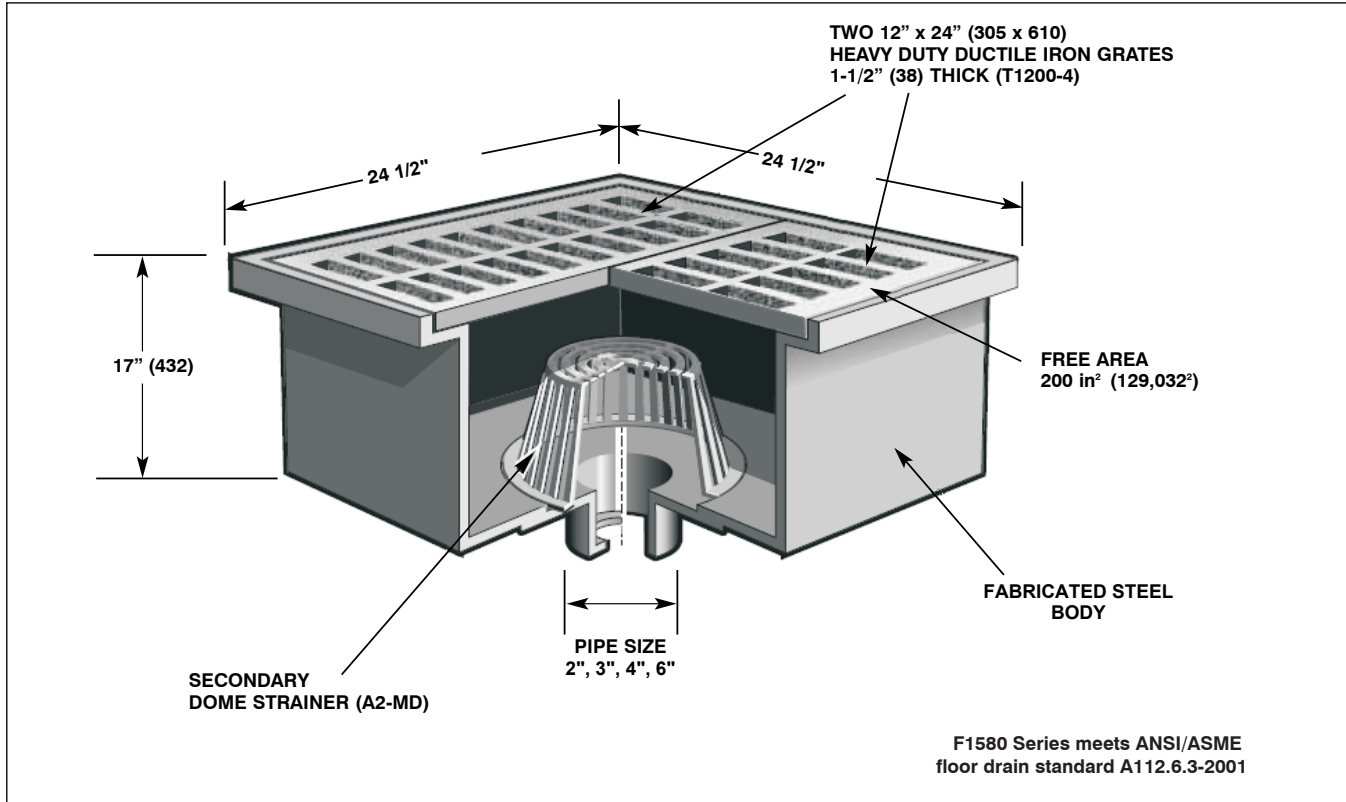

Suffix	Description
-5	Sediment bucket (F1580-SB)
-6	Vandal proof secured grates (TR30 Torx and pin) (H-1072B)
-8	Backwater valve (BV1250 Series) (2", 3", 4")
-12	Galvanized top assembly
-13	All galvanized body
-28	Stainless steel body and grate (Type 304)
-FL	Anchor flange
-FLC	Anchor flange and membrane clamp

CALIFORNIA PROPOSITION 65 WARNING. This product contains chemicals known to the State of California to cause cancer and birth defects or other reproductive harm.

Job Name: _____

Page No: _____

Section No: _____

Contractor: _____

Schedule No: _____

Purchase Order No: _____

Location: _____



F1580

**24" X 24" HEAVY DUTY DEEP SUMP
DRAIN WITH BOTTOM OUTLET**

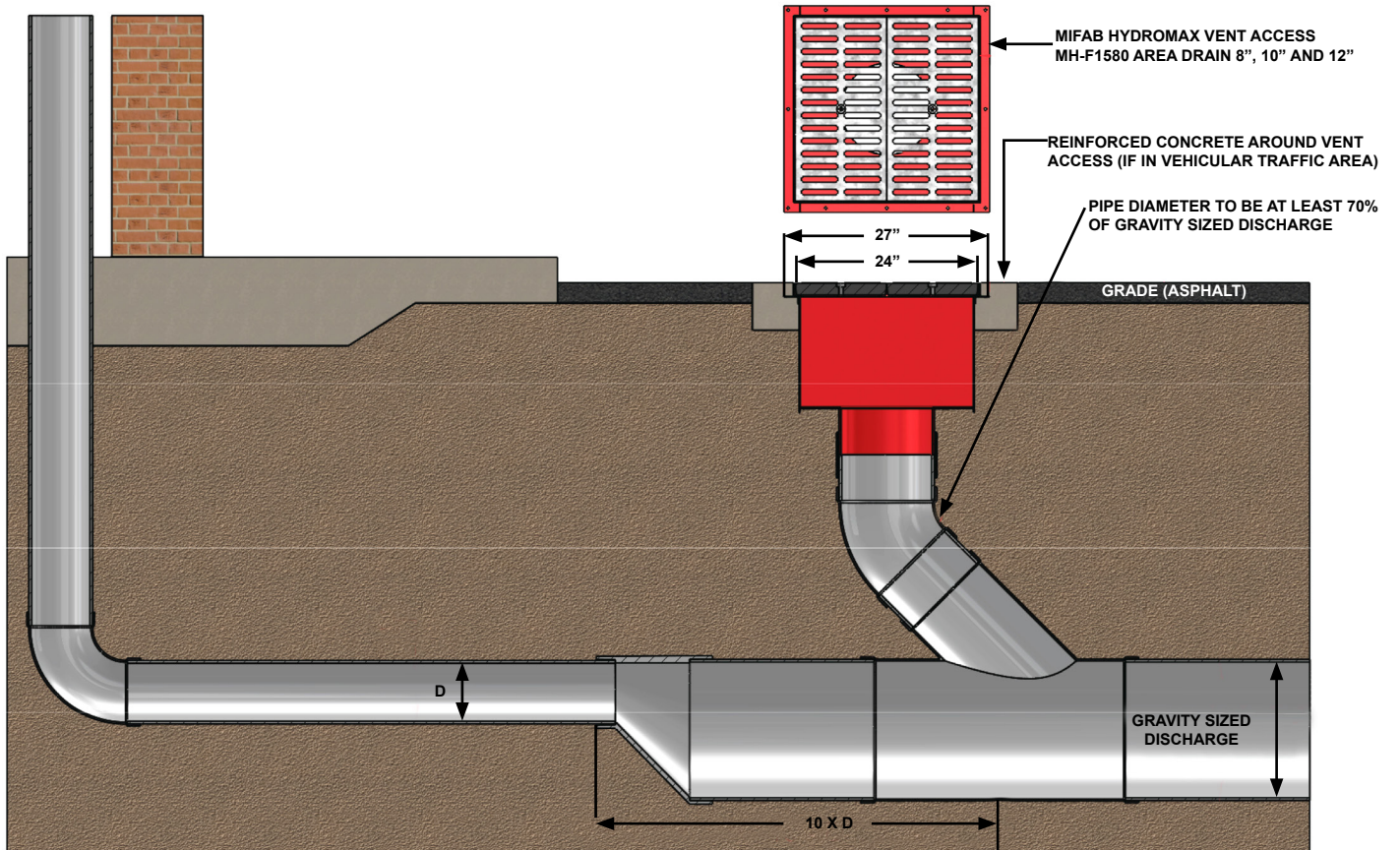

CALIFORNIA PROPOSITION 65 WARNING. This product contains chemicals known to the State of California to cause cancer and birth defects or other reproductive harm.

Job Name: _____

Page No: _____

Section No: _____

Contractor: _____

Schedule No: _____

Purchase Order No: _____

MIFAB® reserves the right to make changes in material and design without formal notice and obligation.

USA: 1-800-465-2736 www.mifab.com CAN: 1-800-387-3880