

Location: _____



MC-41-TR

FIXTURE CARRIER WITH CONCEALED ARMS AND MEASURING PLATES

Specification: MIFAB® Series MC-41-TR floor mounted concealed arm lavatory carrier with lacquered, adjustable, ductile iron concealed support arms and measuring plates. Complete with lacquered cast iron invertible and adjustable arm supporting brackets, adjustable steel nipples with locknut and set screws, measuring plates, two lacquered 2" x 1" x 1/8" thick structural steel uprights with 3" x 4 1/2" welded steel feet and fixture leveling and locking hardware.

Function: Used to support off-the-floor fixtures so that the vertical load bearing components are concealed within the wall. The fixture carrier has no contact with the finished floor inside of the room.

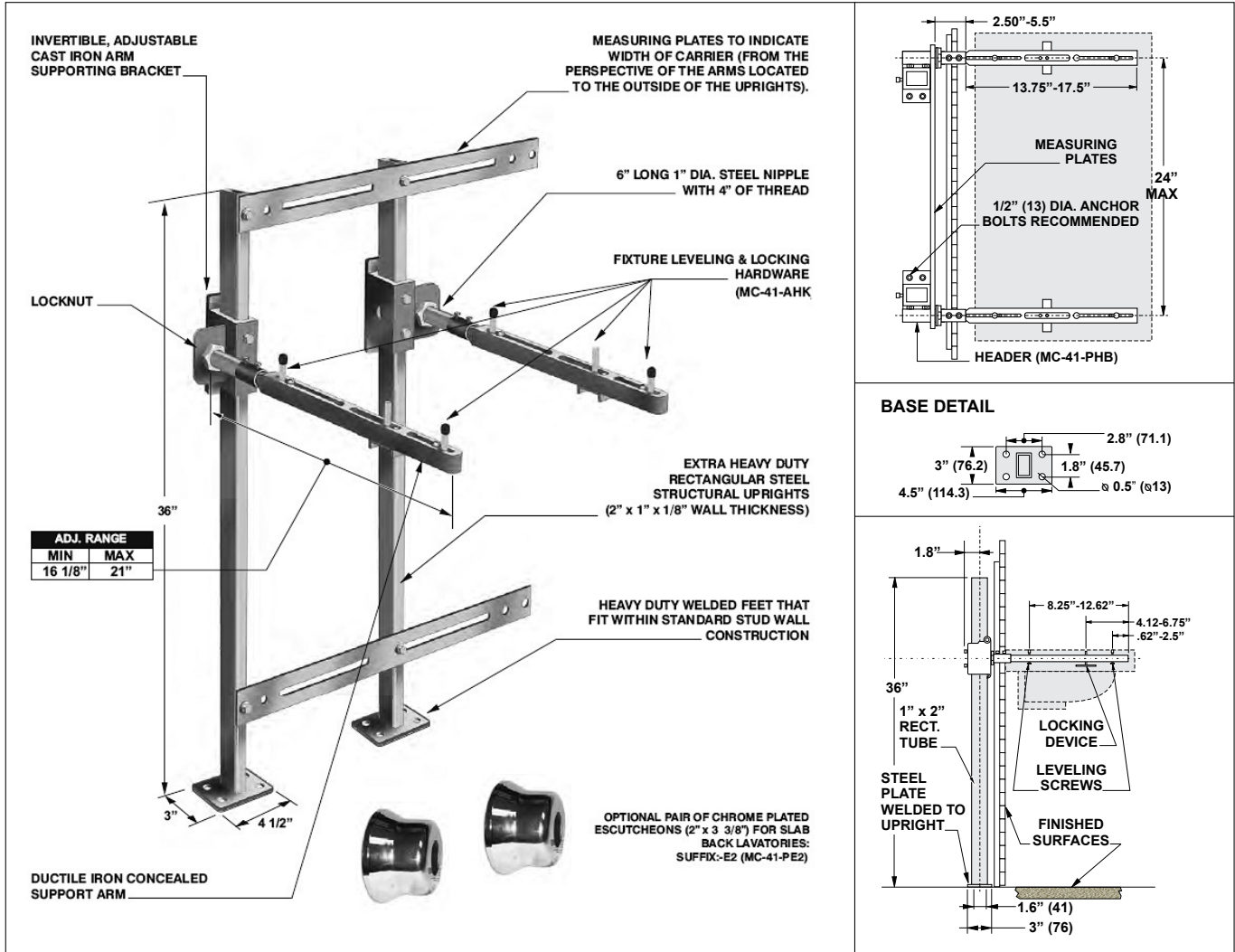

NOTE: FOOT SUPPORTS SHOULD BE SECURELY ANCHORED TO FLOOR WITH 1/2" (13) BOLTS AND ANCHORS BY OTHERS
Note: See the various fixture dimensional rough-in guides on the www.mifab.com website.

SUFFIX	OPTIONAL VARIATIONS
-A	Nipple length over 6" (specify)
-B	Floor to ceiling uprights (specify height required)
-BA	Buy American Act compliant product
-E2	2" chrome plated escutcheons (pair)
-G	Wall support plate
-PA	Pennsylvania Steel Act compliant product
-SL	3/4" Slots in legs – to receive 1/2" water piping through legs
-32	Foot pedal mounting plate

CALIFORNIA PROPOSITION 65 WARNING. This product contains chemicals known to the State of California to cause cancer and birth defects or other reproductive harm.

Job Name: _____ Page No: _____
 Section No: _____ Contractor: _____
 Schedule No: _____ Purchase Order No: _____