

1000-AU Floor Drain Body with Adjustable Top Assembly (Angle Grate)

Project		Engineer		Mechanical	
---------	--	----------	--	------------	--

ASME Load Rating
(-1) Nickel Bronze
Light Duty

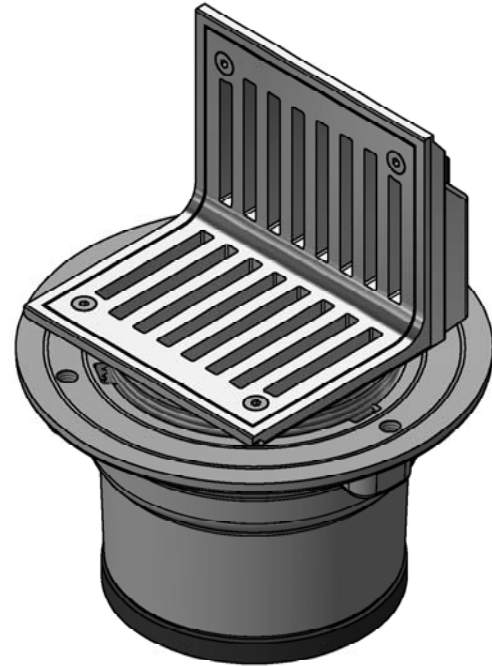
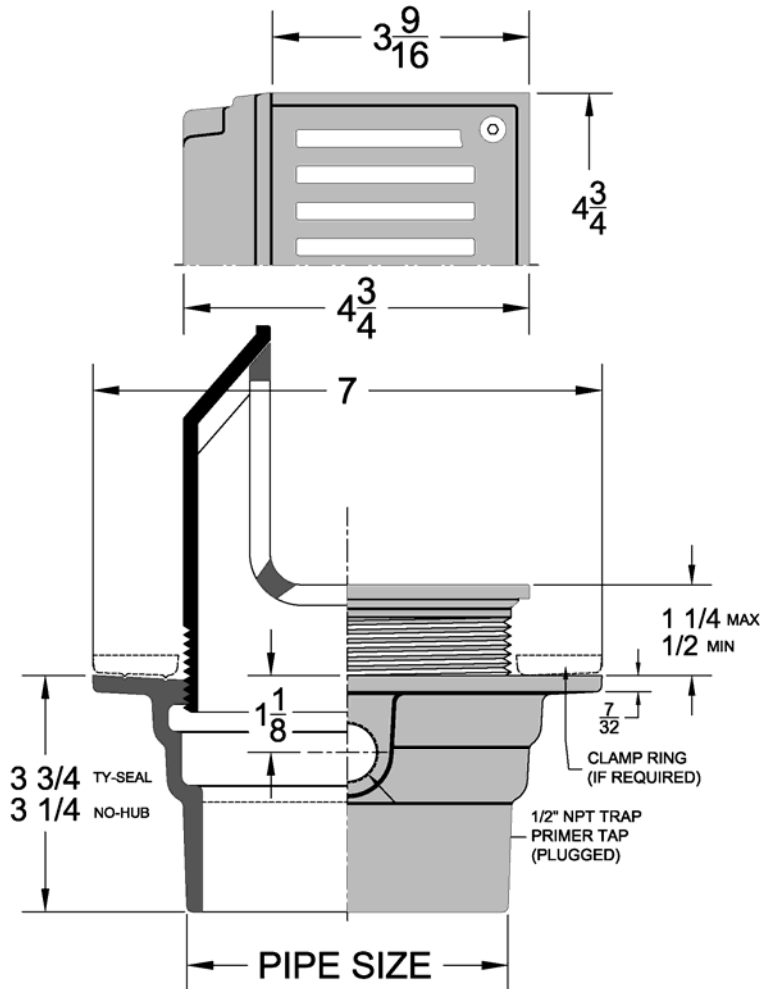

1000-AU5-1-3TY

Top Size & Type	•	Grate Free Area (Sq.In.)
	-1 Cast Iron Body with Satin Finish Nickel Bronze Top	
AU5		11.0

Regularly Furnished: Painted cast iron floor drain body with flange, seepage openings, 1/2" primer tap with plug, & type "AU" top assembly.

Outlet Variations		
Type	Designation	•
No-Hub	2NH,3NH,4NH,6NH	
Push On Gasket	2TY,3TY,4TY	

Suffix Options		
Suffix	Description	•
-DIA	Deck Installation Assembly *	
-SO	90 Degree Side Outlet (2NH,3NH,4NH)	
-TSD	Trap Seal Device (See Model 4405)	
-VP	Vandal Proof Top Assembly	
-26	Clamping Collar for Membrane Floors *	
-26T	Threaded Clamping Collar *	
-27	Sediment Bucket	
-31	Backwater Valve	
-39	Galvanized Cast Iron	
-94	Cast Iron Extension Adapter*	Painted
		-39

*Dimensions vary from illustration