



# HYDRANTS

## INSTALLATION INSTRUCTIONS FOR HYDRANT M-200

Prepare trench for water-supply line. Below hydrant location, prepare hole to trench depth and large enough for a person to work. Lay water-supply line and waste line (if required) into trench, allowing extra line length to be trimmed during hook-up. Depending on design and code requirements, lay in drain line also.

Install hydrant fully assembled as shipped. Position hydrant at desired location. Brace hydrant by laying two boards across hole and under hydrant base, one on either side of outer casing. To ensure plumb installation, place a bubble level against hydrant and adjust bracing boards until unit is plumb.

Purge water-supply line. Connect water-supply line, trimming line length as necessary. Supply water pressure shall not exceed 85 psi. If necessary, install a pressure-reducing valve in the supply line. Wrap bottom drain opening with filter fabric and place a minimum of three cubic feet (0.085 cubic meter) of large round rock under drain opening. Check local codes. Local soil conditions may require more rock for drainage.

Back-fill trench and hole. Compact back-filled earth. Remove bracing boards. If necessary, loosen set screw in base and adjust vertical position of base on outer casing so that bottom of flared part of base is at grade level.

If concrete slab is desired, prepare hole surrounding hydrant to accommodate concrete slab. Spread and compact gravel as necessary. Pour concrete up to bottom of flared part of hydrant base. Finish concrete as necessary.

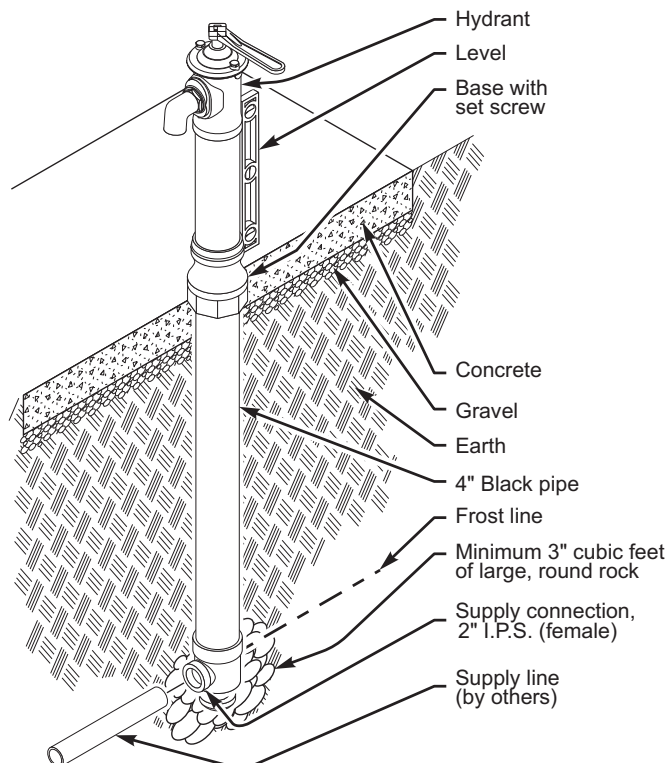

## MAINTENANCE INSTRUCTIONS FOR HYDRANT M-200

All normal maintenance is done from above grade. Washers should normally be replaced annually. Remove bolts and nuts securing top to stock. Lift top from stock, sliding screw flange under top from stirrup. Unscrew and remove nozzle from stock, taking care to catch slide. Take hold of stirrup and raise supply line assembly out of stock-and-outercasing assembly.

At bottom of supply-line assembly, unscrew packing ring from valve body and remove ring washer and cup washer. Remove seat-washer screw and seat washer. Replace seat washer. Replace cup washer and ring washer, and screw packing ring into valve body.

Gently lower supply-line assembly into stock. As stirrup approaches top of stock, lower assembly very carefully to ensure that valve body at bottom of assembly seats properly over valve stem underground.

Rotate stirrup to ensure that nozzle opening in tee is oriented toward opening in stock. Make certain that tee end of nozzle is inserted through slide with tongue of slide oriented toward tee end of nozzle. Apply pipe joint compound to tee end of nozzle, insert tee end of nozzle through opening in stock, and screw nozzle into tee.

Make certain that long side of slide is oriented upward and that slide tongue fits into groove in stock. Tighten nozzle, making certain that nozzle outlet is oriented downward.

