

STANDARD PART #'S		
DOOR SIZE	PART #	LATCH QTY.
12" X 12"	3207014	1
12" X 24"	3207019	2
18" X 18"	3207024	2
24" X 24"	3207030	2
24" X 36"	3207034	3
36" X 36"	3207046	5
36" X 42"	3207048	5

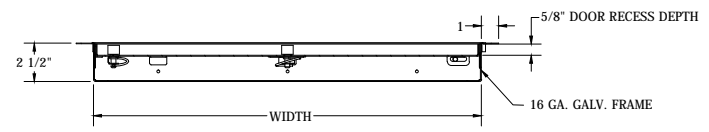
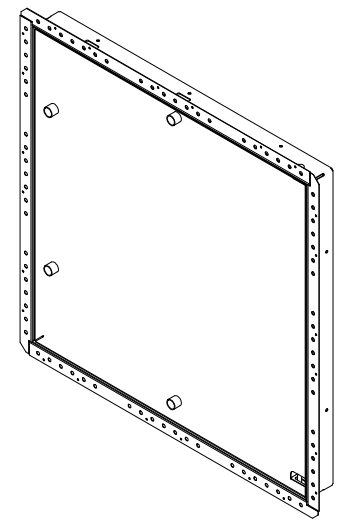

SECTION A-A
FINISH: WHITE POWDER COAT

ORDER WILL NOT BE RELEASED FOR FABRICATION UNTIL SIGNED COPY IS RECEIVED

VERIFICATION AND APPROVAL OF GENERAL ARRANGEMENT AND OVERALL DIMENSIONS OF THIS DOCUMENT ARE REQUIRED BEFORE THE ORDER IS ENTERED FOR MANUFACTURING

APPROVAL SIGNATURE _____

TITLE _____

DATE _____

DRAWN	CD	11/28/2018	Hart & Cooley Inc. Fax: 855-549-2674 www.hartandcooleyinc.com	
CHECKED			5030 Corporate Exchange Blvd. SE Grand Rapids, MI 49512 Ph: 800-624-8642	
QA	TOLERANCE		TITLE	
MFG	UNLESS SPECIFIED		DWR ACCESS DOOR SUBMITTAL	
APPROVED	.XXX	± 0.005"	SIZE	DWG NO
	.XX	± 0.01"	C	SUBMITTAL
		FRACT. ± 1/16"	SCALE	REV
		ANGLES ± 1°		
			SHEET 1 OF 1	