

Location: _____



MHY-30

LOW LEAD MODERATE CLIMATE WALL HYDRANT

Specification: MIFAB® Series MHY-30 exposed type, self draining, moderate climate low lead wall hydrant with A.S.S.E. 1011 certified anti-siphon and vandal resistant integral vacuum breaker with 3/4" (19) male hose connection. Hydrant assembly complete with one piece neoprene plunger to control the flow function, hardened bronze operating stem, heavy duty chrome plated bronze head casting and polished chrome plated face plate. Operating key to be furnished with each hydrant.

Function: Designed to blend in with commercial applications such as office buildings, apartment complexes, malls and shopping centers, schools, churches and industrial buildings.

Plumbing and drainage
Mechanical section

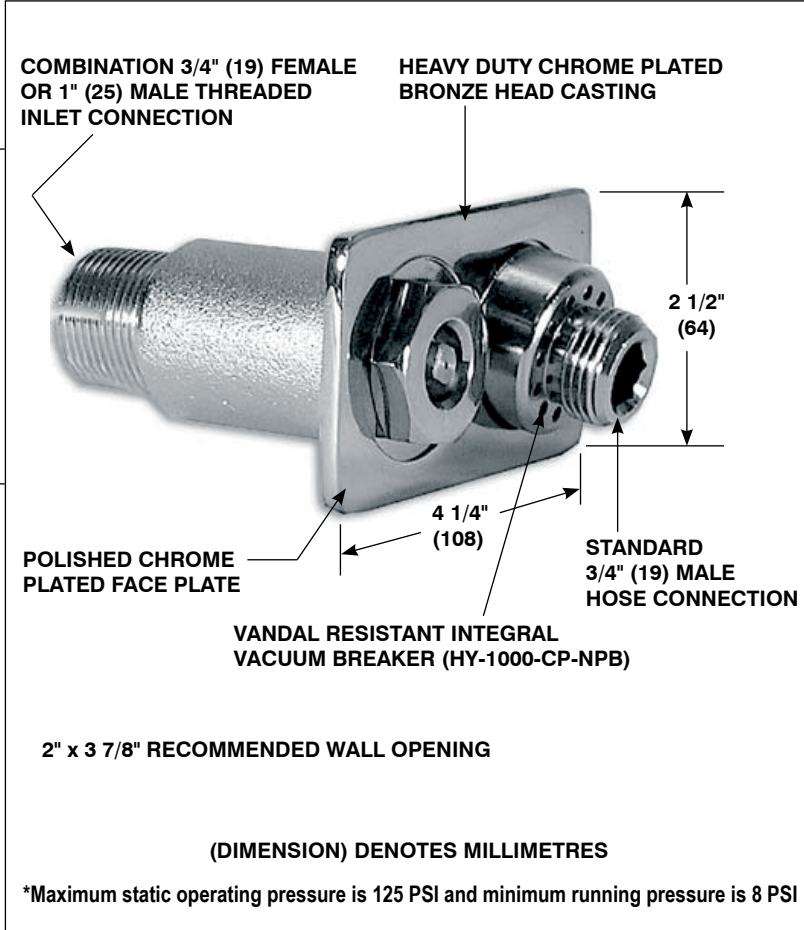

Overhead view

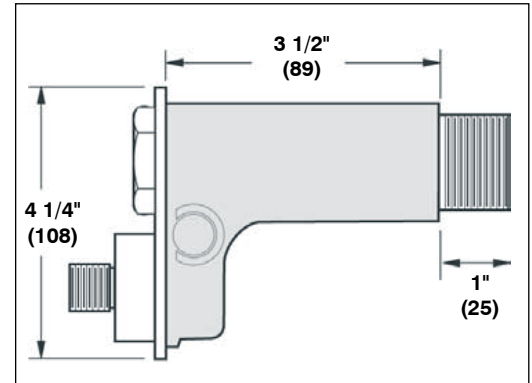

MIFAB MHY-30 Series Features

- **INTERNAL COMPONENTS** - hardened bronze operating stem and neoprene plunger.
- **VACUUM BREAKER** - unique self draining vandal resistant integral vacuum breaker protects from anti-siphon conditions.
- **FACE PLATE** - polished chrome plated.
- **APPROVALS** - MHY-30 Series wall hydrant is listed with I.A.P.M.O. and is manufactured with an anti-siphon vacuum breaker that is tested and certified to the A.S.S.E. Standard 1011.



The wetted surface contacted by consumable water contains less than one quarter of one percent (0.25%) of lead by weight.

MODEL NO.	WALL THICKNESS		OVER LENGTH		APPROXIMATE WEIGHT		SWIVEL INLET CONNECTION
	IN	MM	IN	MM	Lbs.	Kgs.	IN
MHY-30	3 1/2"	114	3 1/2"	114	2	0.9	3/4" Female, 1" Male IPS combination

SUFFIX OPTIONAL VARIATIONS

- BA Buy American Act compliant product
- PA Pennsylvania Steel Act compliant product
- 0 1" (25) Hose connection

CALIFORNIA PROPOSITION 65 WARNING. This product contains chemicals known to the State of California to cause cancer and birth defects or other reproductive harm.

Job Name: _____ Page No: _____

Section No: _____ Contractor: _____

Schedule No: _____ Purchase Order No: _____