

FLOOR OR SHOWER DRAINS WITH ADJUSTABLE STRAINER HEADS

Load Rating: Light Duty having a Safe Live (Static) Load less than 2,000 lbs. (900 kg) per ASME A112.6.3 Floor Drain Standard.
 For the specific Safe Live Load rating of any grate, contact the Smith representative or factory direct.

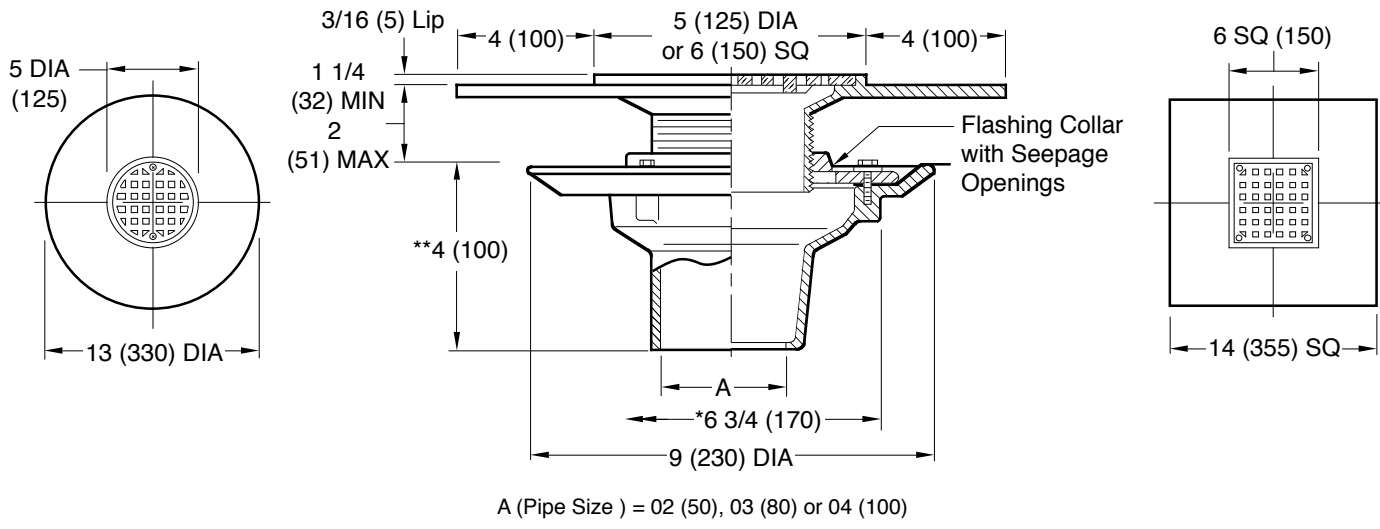

A (Pipe Size) = 02 (50), 03 (80) or 04 (100)

	Fig. DX 2005Y (A) ROUND TOP NO-HUB SQUARE TOP (B) FIG. DX 2005Y	
	Fig. DX 2010C (A) ROUND TOP CAULK SQUARE TOP (B) FIG. DX 2010C	

NOTE: When installing in an above grade floor, a waterproofing membrane is to be ran up to and over the drain body flange and clamped with reversible flashing collar. Membrane covering the center of drain body is to be trimmed to ensure flow through the drain is not blocked or obstructed.
 * Min 6 3/4 (170) hole required for core drilled application.
 ** 3 (76) when threaded outlet is specified.

REGULARLY FURNISHED:

Duco Cast Iron Body with Flashing Collar and Adjustable Strainer as Indicated by Suffix Letter Selected with 4"(100) Wide Flange and Secondary Flashing Flange.

VARIATIONS:

- L Speedi-Set Service Weight (Fig. DX2005 only)
- LXH Speedi-Set Extra Heavy (Fig. DX2005 only)
- Securing Holes -SH
- Sediment Bucket -B
- Vandal Proof Screws -U
- T Threaded Outlet
- Quad Close Trap Seal (Specify Fig. 2692)

OPTIONAL MATERIALS:

- Galvanized Cast Iron Body -G
- Nickel Bronze Strainer -NB
- Polished Bronze Strainer -PB
- Stainless Steel Strainers -SS [Available in 05(125) & 06(150) sizes only]

NOTE: Dimensions shown in parentheses are in millimeters.

DRAWING NUMBER: SDX2005
 SIZE: A
 SCALE: NONE
 DATE: 5-17-85
 APPROVED BY: TD
 CHECKED BY: TD
 DRAWN BY: PJ
DX2005, DX2010
 DIMENSIONS ARE SUBJECT TO MANUFACTURERS TOLERANCE AND CHANGE WITHOUT NOTICE
 WE CAN ASSUME NO RESPONSIBILITY FOR USE OF SUPERSEDED OR VOID DATA

R	9-12-19	Rev. Notes, Reg. Furn. & Drawing	MW	CL	WEIGHT	VOLUME	FIGURE NUMBER
Q	8-26-19	Revised Note	MW	CL	POUNDS	CUBIC FEET	DX2005, DX2010
P	7-23-19	Added Load Rating	MW	JM			
N	6-19-19	Removed Function	MW	JM			
REV.	DATE	DESCRIPTION	BY	CKD. BY			

K
 DRAWING NUMBER PM0457 SH 1 of 2
 SIZE A
 SCALE NONE
 DATE: 5-17-85
 APPROVED BY: TD
 CHECKED BY: TD
 DRAWN BY: PJ
 2010 SERIES OPTIONAL STRAINER HEADS
 FIGURE NUMBER

ASSUME NO RESPONSIBILITY OR USE OF SUPERSEDED OR VOID DATA
 DIMENSIONS ARE SUBJECT TO MANUFACTURERS TOLERANCE AND CHANGE WITHOUT NOTICE

OPTIONAL STRAINER HEADS

ROUND STRAINER

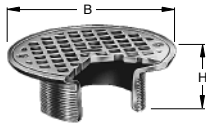

MATERIALS:
 Chrome Plated -CP
 Polished Bronze -PB
 Nickel Bronze -NB
 Stainless Steel
 Strainers -SS [Available in 05(125) & 06(150) sizes only]

VARIATIONS:
 •Hinged Grate (Specify Suffix -AH)
 Sediment Bucket -B
 Vandal Proof Screws -U

B DIA	05 (125)	06 (150)	07 (180)	08 (205)	09 (230)	10 (255)
H	2 (51)	2 (51)	2 1/4 (57)	2 1/2 (64)	2 1/2 (64)	2 3/4 (70)
X MIN	1 1/4 (32)	1 1/4 (32)	1 1/4 (32)	1 1/2 (38)	1 1/2 (38)	1 1/2 (38)
X MAX	2 1/4 (57)	2 1/4 (57)	2 1/4 (57)	2 1/2 (64)	2 1/2 (64)	2 3/4 (70)

LIGHT DUTY

SUFFIX -A

Specify Type, Size & Finish eg: A05NB
 *Not available for 05" (125) size

SQUARE STRAINER

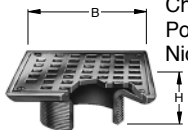

MATERIALS:
 Chrome Plated -CP
 Polished Bronze -PB
 Nickel Bronze -NB

VARIATIONS:
 Flapper Type Backwater Valve (Specify Suffix -BV) 05 (125), 06 (150), 07 (180) or 08" (205) sizes only
 *Hinged Grate (Specify Suffix -BH)
 Sediment Bucket -B
 Vandal Proof Screws -U

B SQ	05 (125)	06 (150)	07 (180)	08 (205)	09 (230)	10 (255)
H	2 (51)	2 (51)	2 1/4 (57)	2 1/2 (64)	2 1/4 (57)	2 1/4 (57)
X MIN	1 1/4 (32)	1 1/4 (32)	1 1/4 (32)	1 1/2 (38)	1 1/2 (38)	1 1/2 (38)
X MAX	2 1/4 (57)	2 1/4 (57)	2 1/4 (57)	2 1/2 (64)	2 1/4 (57)	2 3/8 (60)

LIGHT DUTY

SUFFIX -B

Specify Type, Size & Finish eg: B05NB
 *Not available for 05" (125) size

REINFORCED ROUND STRAINER

FUNCTION: Used in finished floors where light wheeled loads are anticipated.

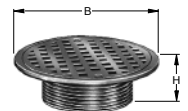

MATERIALS:
 Chrome Plated -CP
 Polished Bronze -PB
 Nickel Bronze -NB

VARIATIONS:
 Flapper Type Backwater Valve (Specify Suffix -CV)
 Sediment Bucket -B
 Vandal Proof Screws -U

B DIA	05 (125)	06 (150)	08 (205)	10 (255)
H	2 (51)	2 (51)	2 1/2 (64)	2 3/4 (70)
MIN	1 1/4 (32)	1 1/4 (32)	1 1/2 (38)	1 7/8 (48)
MAX	2 1/4 (57)	2 1/4 (57)	2 1/2 (64)	2 3/4 (70)

LIGHT DUTY

SUFFIX -C

Specify Type, Size & Finish eg: C06NB

TILE FLANGE

FUNCTION: Provides integral flange set 5/32"(4) below rim to receive floor covering. Flange may have option of tapped holes for securing pan and gasket.

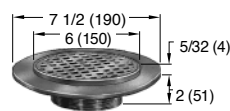

MATERIALS:
 Chrome Plated -CP
 Polished Bronze -PB
 Nickel Bronze -NB

VARIATIONS:
 Flapper Type Backwater Valve (Specify Suffix -FV)
 Holes in Flange -SH
 Sediment Bucket -B
 Vandal Proof Screws -U

	X
MIN	MAX
1 1/4 (32)	2 1/8 (54)

LIGHT DUTY

SUFFIX -F

Specify Type, Size & Finish eg: F06NB

FLAPPER TYPE BACKWATER VALVE

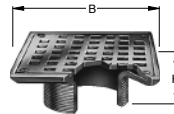

FUNCTION: Provides backwater protection at point where protection is needed.

MATERIALS:
 Chrome Plated -CP
 Polished Bronze -PB
 Nickel Bronze -NB

VARIATIONS:
 •Hinged Grate (Specify Suffix -AH)
 Vandal Proof Screws -U

B SQ	05 (125)	06 (150)	07 (180)	08 (205)
H	2 (51)	2 (51)	2 1/4 (57)	2 1/2 (64)
X MIN	1 1/4 (32)	1 1/4 (32)	1 1/4 (32)	1 1/2 (38)
X MAX	2 1/4 (57)	2 1/4 (57)	2 1/4 (57)	2 1/2 (64)

LIGHT DUTY

SUFFIX -AV

Specify Type, Size & Finish eg: AV05NB
 *Not available for 05" (125) size

STRAINER HEAD w/SQUARE HINGED COVER

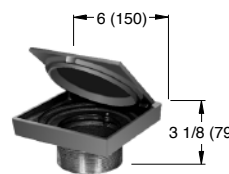

MATERIALS:
 Chrome Plated -CP
 Polished Bronze -PB
 Nickel Bronze -NB

VARIATIONS:
 Gasketed Water Tight Cover -GC
 Secured Cover -SC
 Secondary Strainer Grate -SG

LIGHT DUTY

SUFFIX -BS

Specify Type, Size & Finish eg: BSNB

REINFORCED TRACTOR STRAINER

FUNCTION: Used in finished floors where light weight wheeled loads are anticipated and loose set non-tilt tractor grate is desired.

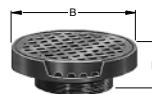

MATERIALS:
 Cast Iron -CI
 Chrome Plated -CP
 Polished Bronze -PB
 Nickel Bronze -NB

VARIATIONS:
 Flapper Type Backwater Valve (Specify Suffix -DV or -EV)
 Sediment Bucket -B
 Vandal Proof Screws -U

SUFFIX	B DIA	H	X	
-D	07 (180)	3 1/4 (83)	2 5/8 (67)	3 1/2 (89)
-E	09 (230)	3 1/2 (89)	2 3/4 (70)	3 1/2 (89)

LIGHT DUTY

SUFFIX -D-E

Specify Type, Size & Finish eg: D09PB
 E09PB

ADJUSTABLE STRAINER HEAD

FUNCTION: Used in a non-traffic area when a funnel type strainer head is required and space does not allow use of the 3500 series funnel. The extended rim allows use as an anti-flood and anti-splash drip pan.

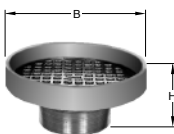

VARIATIONS:
 Flapper Type Backwater Valve (Specify Suffix -F37V or F38V)

MATERIALS:
 Cast Iron -CI
 Chrome Plated -CP
 Galvanized Cast Iron -G
 Polished Bronze -PB
 Nickel Bronze -NB

SUFFIX	-F37	-F38
B DIA	07 (180)	09 (230)
H	3 1/4 (83)	3 1/2 (89)
X MIN	2 5/8 (67)	2 3/4 (70)
X MAX	3 1/2 (89)	3 1/2 (89)

NON-TRAFFIC

SUFFIX -F37-F38

Specify Type, Size & Finish eg: F37NB F38CP

REV.	DATE	DESCRIPTION	BY	CKD. BY	FIGURE NUMBER
K	7-29-19	Added Load Rating(s)	MW	JM	2010 SERIES OPTIONAL STRAINER HEADS 1 of 2
J	6-18-19	Revised DIA to SQ Suf -AV, -B	TBW	TK	
H	11-3-16	Revised Suffix-A	TBW	CL	
G	10-4-01	Revised Suffix-BS	RN	CL	

NOTE: Dimensions shown in parentheses are in millimeters.

OPTIONAL STRAINER HEADS

DRAWING NUMBER: PM0457 SH 2 of 2
 SIZE: A
 SCALE: NONE
 DATE: 5-17-85
 APPROVED BY: TD
 CHECKED BY: TD
 DRAWN BY: PJ
 DIMENSIONS ARE SUBJECT TO MANUFACTURERS TOLERANCE AND CHANGE WITHOUT NOTICE

ASSUME NO RESPONSIBILITY OR USE OF SUPERSEDED OR VOID DATA

LOW DOME STRAINER

FUNCTION: Used in gutters and recessed areas where excessive debris build-up is expected. Dome insures drainage even when partly covered.

MATERIALS:
 Chrome Plated -CP
 Polished Bronze -PB
 Nickel Bronze -NB

VARIATIONS:
 Flapper Type Backwater Valve (Specify Suffix -GV)
 Sediment Bucket -B
 Vandal Proof Screws -U



B DIA	05 (125)	06 (150)	08 (205)
H	2 (51)	2 (51)	2 1/2 (64)
MIN	1 1/4 (32)	1 1/4 (32)	1 1/2 (38)
MAX	2 1/4 (57)	2 1/4 (57)	2 1/2 (64)

SUFFIX -G Specify Type, Size & Finish eg: G08PB

SOLID HINGED COVER

FUNCTION: Used in areas where intermittent drain use is required. Solid cover prevents intrusion of chips, saw-dust, etc., which are swept up before cover is opened for washdown. The secondary strainer prevents debris from entering the waste line.

MATERIALS:
 Chrome Plated -CP
 Polished Bronze -PB
 Nickel Bronze -NB

VARIATIONS:
 Flapper Type Backwater Valve (Specify Suffix -GV)
 Vandal Proof Screws -U



B DIA	05 (125)	06 (150)	07 (180)	08 (205)
H	2 (51)	2 (51)	2 1/4 (57)	2 1/2 (64)
X MIN	1 1/4 (32)	1 1/4 (32)	1 1/4 (32)	1 1/2 (38)
MAX	2 1/4 (57)	2 1/4 (57)	2 1/4 (57)	2 1/2 (64)

SUFFIX -H Specify Type, Size & Finish eg: H05CP

SPANNER WRENCH COVER

FUNCTION: Solid gas tight, vandal proof, threaded cover for areas where intermittent drain use is required.

MATERIALS:
 Chrome Plated -CP
 Polished Bronze -PB
 Nickel Bronze -NB

VARIATIONS:
 Flapper Type Backwater Valve (Specify Suffix -JV)
 Sediment Bucket -B

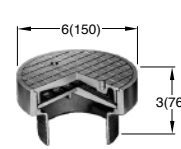

MEDIUM DUTY	
X	MIN MAX
	2 (51) 3 (76)

SUFFIX -J Specify Type, Size & Finish eg: J06NB

REINFORCED SQUARE STRAINER

FUNCTION: Used in finished floors where some light wheeled traffic is anticipated.

MATERIALS:
 Chrome Plated -CP
 Polished Bronze -PB
 Nickel Bronze -NB

VARIATIONS:
 Flapper Type Backwater Valve (Specify Suffix -KV)
 Sediment Bucket -B
 Vandal Proof Screws -U

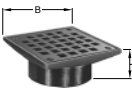

B SQ	05 (125)	06 (150)	07 (180)	08 (205)
H	2 (51)	2 (51)	2 1/4 (57)	2 1/2 (64)
X MIN	1 1/4 (32)	1 1/4 (32)	1 1/4 (32)	1 1/2 (38)
MAX	2 1/4 (57)	2 1/4 (57)	2 1/4 (57)	2 1/2 (64)

SUFFIX -K Specify Type, Size & Finish eg: K07CP

RECTANGULAR STRAINER

FUNCTION: Used in finished floors where light wheeled loads and or heavy foot traffic are anticipated.

MATERIALS:
 Chrome Plated -CP
 Polished Bronze -PB
 Nickel Bronze -NB

VARIATIONS:
 Sediment Bucket -B
 Vandal Proof Screws -U

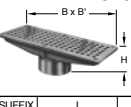

SUFFIX	L	M	N	P	R	T
B x B'	4 1/2(115)x8(205)	4(100)x12(305)	5(125)x9(230)	5(125)x13(330)	6(150)x10(255)	5(125)x17(430)
H	2 1/4 (57)	2 1/2 (64)	2 1/4 (57)	3 (76)	2 1/4 (57)	3 (76)
X MIN	1 3/8 (35)	1 7/8 (48)	1 3/8 (35)	2 1/8 (54)	1 3/8 (35)	2 1/4 (57)
MAX	2 3/8 (60)	2 3/4 (70)	2 3/8 (60)	3 (76)	2 3/8 (60)	3 1/8 (79)

SUFFIX -L-M-N-P-R-T Specify Type, Size & Finish eg: LNB

ANGLE STRAINER

FUNCTION: Shower room drain set at wall and floor junction. Vertical grate openings prevent drain stoppage should flat surface become covered.

MATERIALS:
 Chrome Plated -CP
 Polished Bronze -PB
 Nickel Bronze -NB

VARIATIONS:
 Vandal Proof Screws -U

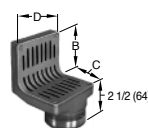

SUFFIX	B	C	D	X	
				MIN	MAX
-V	3 1/2 (89)	3 1/2 (89)	4 1/2 (115)	1 5/8 (41)	2 5/8 (67)
-W	6 3/4 (170)	6 3/4 (170)	6 1/2 (165)	1 5/8 (41)	2 5/8 (67)

SUFFIX -V -W Specify Type, Size & Finish eg: VPB, WNB

EXTENSION ADAPTOR

FUNCTION: Used when a strainer head must be raised to accommodate deeper floor fill.

REGULARLY FURNISHED:
 Duco Cast Iron -CI

MATERIALS:
 Cast Bronze -CB
 Galvanized Cast Iron -G

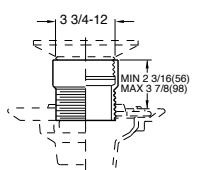

NOTE: Extension can be stacked for increased maximum adjustment.

SUFFIX -X

OVERFLOW WITH STANDPIPE

FUNCTION: Used as overflow drain in decorative pools, fish ponds or similar areas. Dome prevents floating objects from entering drain line.

MATERIALS:
 Chrome Plated -CP
 Nickel Bronze -NB
 Polished Bronze -PB

VARIATIONS:
 Less Dome -LD
 Standpipe Height other than 6" (150) (Specify Height)

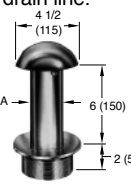

SUFFIX	A	X	
	SIZE	MIN	MAX
-Y	2 (51)	3/4 (19)	2 1/8 (54)
-Z	3 (76)	3/4 (19)	2 1/8 (54)

SUFFIX -Y-Z Specify Type, Size & Finish eg: YCP, ZCP

HEAVY DUTY ADJUSTABLE

FUNCTION: Used in finished floors where light wheeled loads and or heavy foot traffic are anticipated.

MATERIALS:
 Polished Bronze -PB
 Rough Bronze -RB
 Nickel Bronze -NB

VARIATIONS:
 Flapper Type Backwater Valve (Specify Suffix -69V)
 Sediment Bucket -B
 Vandal Proof Screws -U

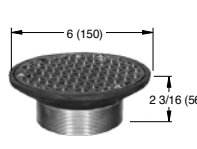

SUFFIX -69 eg: A06NB-69

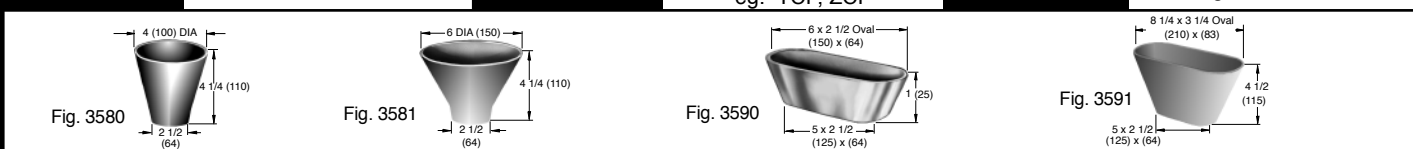

L	7-29-19	Added Load Rating(s) Rev. Materials Suffix -H, -V-W Rev. Variations of Suffix -J Revised Revised Tables	MW	JM	FIGURE NUMBER 2010 SERIES OPTIONAL STRAINER HEADS 2 of 2
K	10-20-17		TBW	CL	
J	1-17-12		TBW	AM	
H	8-24-99		TBW	BS	
G	6-11-99		CMD		
REV.	DATE	DESCRIPTION	BY	CKD. BY	

NOTE: Dimensions shown in parentheses are in millimeters.



WARNING: Cancer and Reproductive Harm - www.P65Warnings.ca.gov