

B

SMITH® JAY R. SMITH MFG. CO.®
 MEMBER OF MORRIS GROUP INTERNATIONAL
 POST OFFICE BOX 3237
 MONTGOMERY, ALABAMA 36109-0237 (USA)
 TEL: 334-277-8520 FAX: 334-272-7396 www.jrsmith.com



LOCATION

DRAWING NUMBER
S3039-DID

SIZE
A

SCALE:
NONE

DATE:
8-28-08

APPROVED BY:
BW

CHECKED BY:
BW

DRAWN BY:
RN

3039-DID

WE CAN ASSUME NO RESPONSIBILITY FOR USE OF SUPERSEDED OR VOID DATA
DIMENSIONS ARE SUBJECT TO MANUFACTURERS TOLERANCE AND CHANGE WITHOUT NOTICE

FormIt® DRAIN INSTALLATION DEVICE FOR 12" SQUARE ENAMELED FLOOR SINK SERIES

FUNCTION: The Jay R. Smith Mfg. Co.® FormIt® Drain Installation Device is designed to stabilize the drain and provide adjustment during the installation process and allows final connection of outlet piping to drain after the concrete pour.

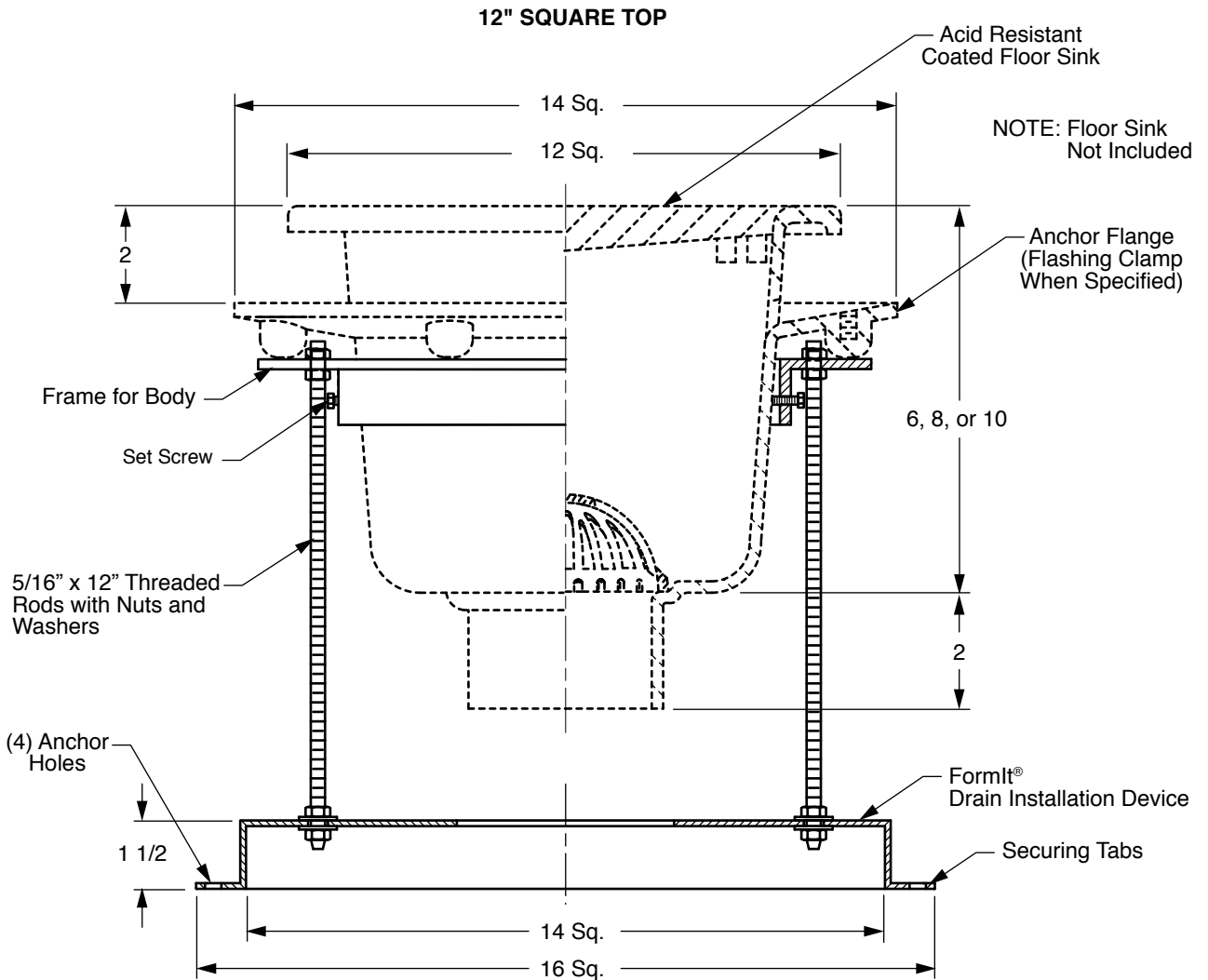

A (Pipe Size) = 02, 03 or 04

REGULARLY FURNISHED:

FormIt® Drain Installation Device for 12" Square Enameled Floor Sink Series.

REV.	DATE	DESCRIPTION	BY	CKD. BY
B A	7-7-10 05/14/09	Revised™ to® Added Function	RN JJ	BW BW

WEIGHT POUNDS	VOLUME CUBIC FEET

FIGURE NUMBER 3039-DID
