

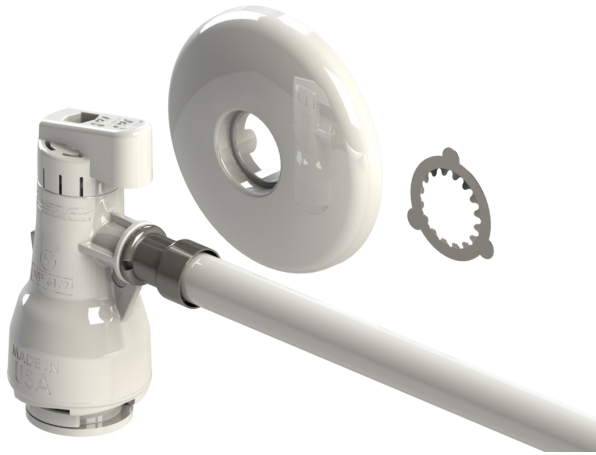

Ultra-EZ Push-on Angle Stop Connector Specification Sheet



DESIGN FEATURES

- For use in potable water distribution systems
- Easy Push to Connect supply stop
- Intuitive 1/4 turn on/off design
- 100% Leak tested
- Works with Copper, PEX, CPVC, and PE-RT piping
- 5 year limited warranty
- Made in the USA
- Industry standard universally accepted release design
- Packaged in quantities of 10

MATERIAL SPECIFICATIONS

- Chemical resistant engineered polymer. Excellent chemical, oxidation scaling, mineral build-up, and heat resistance.
- Chloramine resistant rubber components
- Patented Ultracore™ hose liner with corrosion resistant PET braid.

OPERATING SPECIFICATIONS

- To turn On, rotate handle 1/4 turn until aligned with the outlet.
- To turn Off, rotate handle 1/4 turn until tip is perpendicular to the outlet direction
- Working Temperature: 40°-160°F
- Max working pressure 125 PSI



3689 Arrowhead Drive, Carson City, NV 89706
 Phone (800) 854-3215 Fax (800) 243-1777
 E-mail sales@lspproducts.com
 Website www.lspproducts.com

Content matter is subject to change at any time. It is the user's responsibility to ensure the most updated revisions are obtained.

| Part Number | Description | Hose Length | Usage |
|---------------|--|--|------------|
| PV-DW160 | 1/2" Quick Connect x 3/8" Comp. w/ 3/4" FGHT Elbow Adapter Engineered Polymer Push-On Valve | 60" | Dishwasher |
| PV-IM172 | 1/2" Quick Connect x 1/4" Comp. Hard Cone Connection Engineered Polymer Push-On Valve | 72" | Ice Maker |
| Accessories | | | |
| FTG-05-0380-L | | Dishwasher 3/8" NPT x 3/8" Comp. Elbow Adapter | |

CAUTION

- Do NOT expose to flux, PVC/CPVC primers or glues, household cleaners, external heat sources, or corrosive materials
- **Do not reuse valve once it has been installed and removed from a pipe.**

COMPLIANCES/LISTINGS

- IAPMO listed
 - ASME A112.18.1/CSA B125.1, ASSE 1061 (File # 4577)
 - ASME A112.18.6/CSA B125.6 (File # 2111)
 - Lead Free Compliance (File #6545)
 - NSF/ANSI-61/9 (File # N-6614)
- NSF 61



MAINTENANCE

- Keep dry. Inspect every six months and replace immediately in the event of leaks, wear, discoloration, and any visible signs of corrosion.
- Do not clean with harsh household chemicals. Wipe clean with water and a clean cloth

| Product Submittal | |
|-------------------|----------|
| Job Name: | |
| Date: | |
| Part Number | Quantity |
| | |
| | |
| Architect: | |
| Contractor: | |



**Ultra-EZ Push-on
Angle Stop Connector
Specification Sheet**

INSTALLATION INSTRUCTIONS

1. Cut 1/2" stub out pipe no less than 2- 1/2" from the wall. End should be square. **To prevent leaks, ensure pipe (ESPECIALLY COPPER) surface is free of burrs, scratches or other damages.**
2. Install escutcheon onto pipe and press against wall.
3. Install spare metal grab ring onto pipe and push completely against escutcheon.
4. Mark the pipe at a depth of 1-3/8", place the notch on the back of the valve flush with the end of the pipe and mark pipe.
5. Push the valve onto the pipe until the bottom of valve has passed the marking on the pipe. Do not use pipe dope or expose to flux or CPVC/PVC Cements or Primers. When installing a hose, hand tighten nuts plus 1/4 turn with a wrench. **DO NOT USE A HARD CONE CONNECTION. DO NOT OVER TIGHTEN.**
6. Connect hose to appliance. Do not twist, kink, crush, or pull line up against valve or connection fitting.
7. After installation, pressure test and check for leaks prior to leaving site.

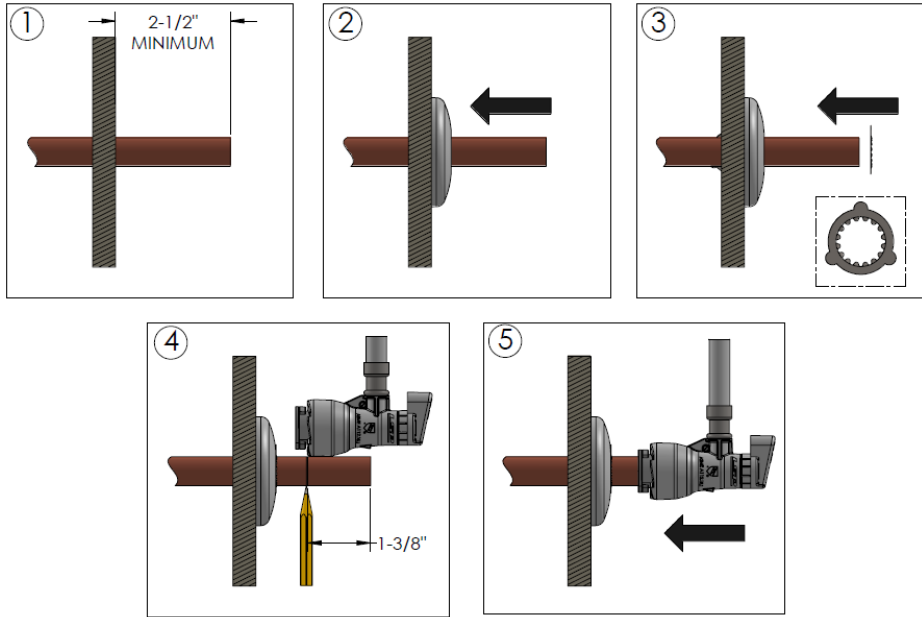

REMOVAL INSTRUCTIONS

1. Turn off water main.
2. Remove the small retaining clip on the bottom of the valve with needle-nose pliers or a flat head screwdriver.
3. Place the end of LSP part number OBPS-TOOL-1, or a 5/8" wrench against the release collar or other device/tool over the pipe below/ behind the valve.
4. Pull the tool against the release collar to release the internal teeth of the valve, then pull the valve off the pipe.
5. **DO NOT REUSE ONCE REMOVED FROM A PIPE.**



3689 Arrowhead Drive, Carson City, NV 89706 Phone
 (800) 854-3215 Fax (800) 243-1777
 E-mail sales@lspproducts.com
 Website www.lspproducts.com
 Content matter is subject to change at any time. It is the user's responsibility to ensure the most updated revisions are obtained.

| Product Submittal | |
|-------------------|----------|
| Job Name: | |
| Date: | |
| Part Number | Quantity |
| | |
| | |
| Architect: | |
| Contractor: | |