

1640 Floor Drain with Round Fixed Top – Slotted Grate

Regularly Furnished: Painted cast iron floor drain with ductile iron slotted grate, medium sump body, ½" NPT trap primer tap (plugged) and bottom outlet. ASME Load Rating = X.H. (Extra Heavy Duty) 7,500-10,000 Lbs.

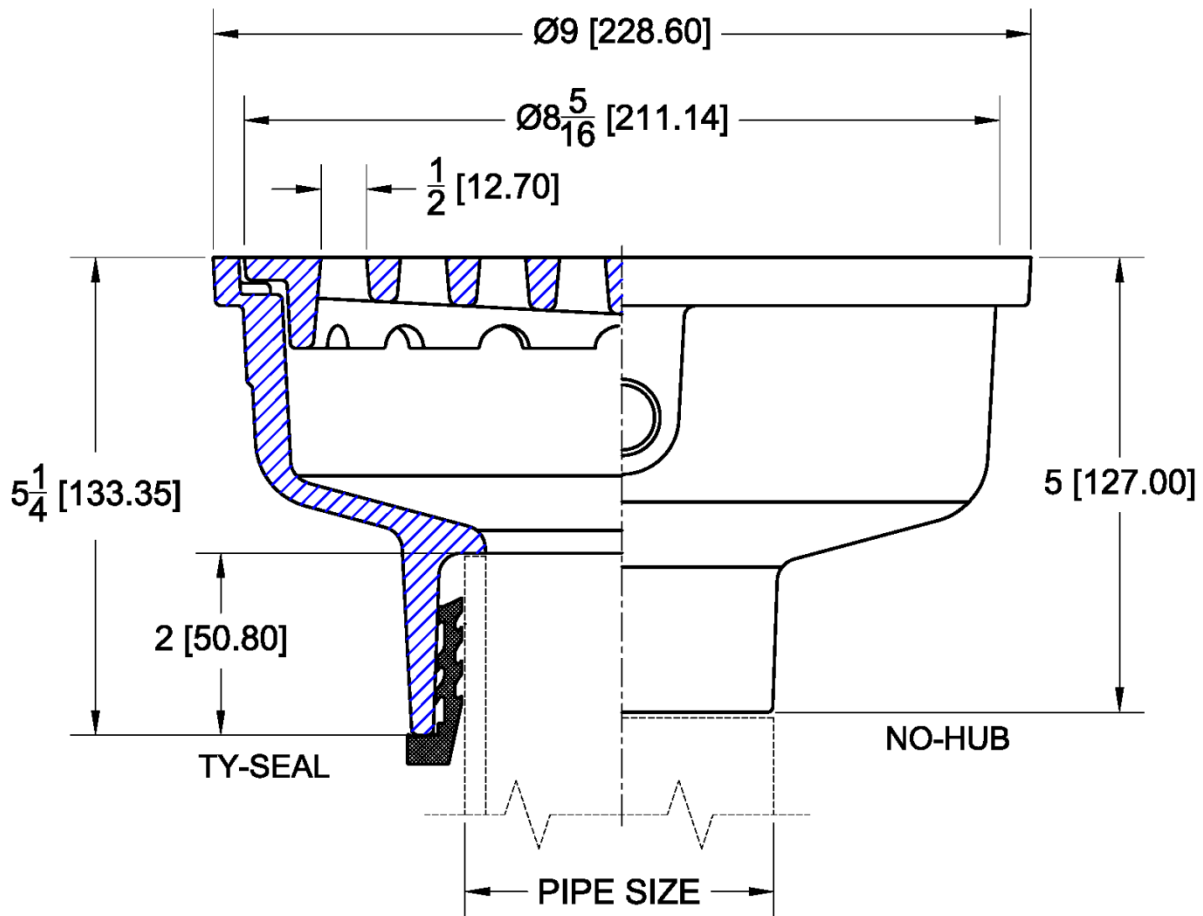

Top Material		
✓	Suffix	Description
	-1	Satin Finish Nickel Bronze Veneer
	-2	Satin Finish Bronze Veneer
	-12	Ductile Iron
	-102	Polished Chrome Plated Brass Veneer
	-304	Satin Finish 304 Stainless Steel Veneer

Outlet Variations		
✓	Type	Designation
	No-Hub	2NH, 3NH, 4NH
	Push-On	2TY, 3TY, 4TY

Funnels		
✓	Suffix	Description
	-EF4	4" Round Funnel Assembly
	-EF6	6" Round Funnel Assembly
	-EG8	8" Elongated Funnel Assembly

Options		
✓	Suffix	Description
	-ARC	Acid Resistant Coating (C.I. Parts)
	-TSD	Trap Seal Device (Model 4405)
	-TD	Grate Supported Bucket
	-VP	Vandal Proof Secured Grate
	-7	Dome Grate
	-8	Secondary Strainer
	-11	Heel Proof Grate
	-18	Solid Cover
	-23	Grate Riser (1-1/2" High)
	-27	Sediment Bucket
	-31	Backwater Valve (2,3,4" Only)
	-33	Closure Plug
	-39	Galvanized Iron Parts
	-81	Solid Gasketed Cover
	-123	Stainless Steel Mesh Lined Bucket