

FLOOR OR SHOWER DRAINS WITH ADJUSTABLE STRAINER HEADS

General service floor drain for use in showers, toilets, kitchens, and other finished areas where foot traffic is expected.
 Load Rating: Light Duty having a Safe Live (Static) Load less than 2,000 lbs. (900 kg) per ASME A112.6.3 Floor Drain Standard.
 For the specific Safe Live Load rating of any grate, contact the Smith representative or factory direct.

DRAWING NUMBER: S2020
 SIZE: A
 SCALE: NONE
 DATE: 5-17-85
 APPROVED BY: TD
 CHECKED BY: TD
 DRAWN BY: PJ
 FIGURE NUMBER: 2020, 2021, 2030, 2031, 2040, 2041
 DIMENSIONS ARE SUBJECT TO MANUFACTURERS TOLERANCE AND CHANGE WITHOUT NOTICE
 WE CAN ASSUME NO RESPONSIBILITY FOR USE OF SUPERSEDED OR VOID DATA

SHALLOW TRAP - SIDE OUTLET

A SIZE	B	D	E	F Seal	G	H	MIN-X-MAX	
02 (51)	05 (125)	1 3/4 (44)	5 (125)	2 (51)	6 3/4 (170)	9 1/2 (240)	1 1/4 (32)	2 1/4 (57)
03 (76)	06 (150)	2 1/4 (57)	4 1/2 (115)	2 (51)	9 (230)	12 1/4 (310)	1 1/4 (32)	2 1/4 (57)
04 (100)	08 (205)	3 (76)	8 1/2 (215)	2 1/2 (64)	10 (255)	12 3/4 (325)	1 1/2 (38)	2 1/2 (64)

THREAD OUTLET ***SPIGOT OUTLET**
Fig. 2020T ... (A) ROUND TOP ... 2021S
Fig. 2020T ... (B) SQUARE TOP ... 2021S

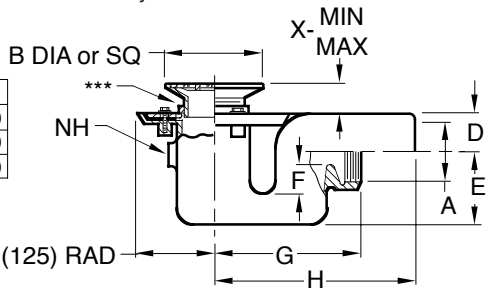

DEEP TRAP - SIDE OUTLET

A SIZE	B	D	E	F Seal	G	H	MIN-X-MAX	
02 (51)	05 (125)	1 3/4 (44)	5 1/4 (135)	2 (51)	5 (125)	8 (205)	1 1/4 (32)	2 1/4 (57)
03 (76)	06 (150)	2 (51)	7 (180)	2 1/4 (57)	8 (205)	10 (255)	1 1/4 (32)	2 1/4 (57)
04 (100)	08 (205)	3 (76)	8 1/2 (215)	2 1/2 (64)	10 (255)	12 3/4 (325)	1 1/2 (38)	2 1/2 (64)

THREAD OUTLET ***SPIGOT OUTLET**
Fig. 2030T ... (A) ROUND TOP ... 2031S
Fig. 2030T ... (B) SQUARE TOP ... 2031S

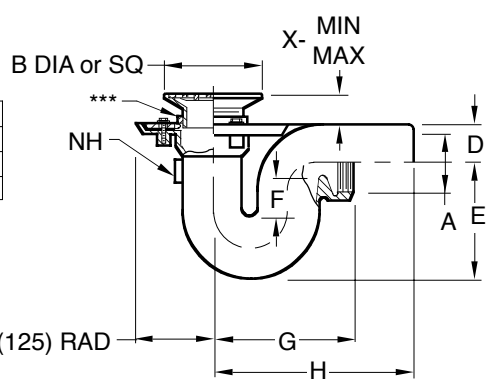

DEEP TRAP WITH FLOOR CLEANOUT - SIDE OUTLET

A SIZE	B	MIN-X-MAX	
02 (51)	05 (125)	1 1/4 (32)	2 1/4 (57)
03 (76)	06 (150)	1 1/4 (32)	2 1/4 (57)
04 (100)	08 (205)	1 1/2 (38)	2 1/2 (64)

THREAD OUTLET ***SPIGOT OUTLET**
Fig. 2040T ... (A) ROUND TOP ... 2041S
Fig. 2040T ... (B) SQUARE TOP ... 2041S

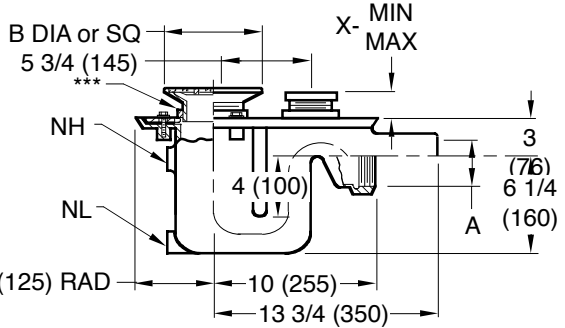

REGULARLY FURNISHED:
 Duco Cast Iron Body and Flashing Collar, Adjustable Strainer Head, with Secured Grate. Type of Body and Strainer Head as Indicated by Figure Number and Strainer Suffix Letter Selected.

SEE PM0457 FOR OPTIONAL STRAINER HEADS.

- VARIATIONS:**
- Ball Float Backwater Valve -BFV
 - High Auxiliary Inlet -NH (1 1/2 (38) or 2" (51))
 - Hinged Grate -H
 - Low Auxiliary Inlet -NL (Fig. 2040 only)
 - Sediment Bucket -B
 - Trap Primer Connection -P050 (1/2" (13)) & -P075 (3/4" (19))
 - Vandal Proof Screws -U

- OPTIONAL MATERIALS:**
- Bronze Body -BB
 - Chrome Plated Strainer -CP
 - Galvanized Cast Iron -G
 - Nickel Bronze Strainer -NB
 - Polished Bronze Strainer -PB

* Sized for service weight and/or NO-HUB.
 ** Not available for 5" (125) size strainer.
 *** Collar can be used in high position only.

REV.	DATE	DESCRIPTION	BY	CKD. BY	WEIGHT POUNDS	VOLUME CUBIC FEET	FIGURE NUMBER
J	7-23-19	Added Load Rating	MW	JM			2020, 2021, 2030 2031, 2040, 2041
H	6-14-19	Removed Function	MW	JM			
G	3-21-95	Added Metric	EMB	BS			
F	7-1-94	Revised	CMB	BS			

K
 DRAWING NUMBER PM0457 SH 1 of 2
 SIZE A
 NONE
 SCALE
 DATE: 5-17-85
 APPROVED BY: TD
 CHECKED BY: TD
 DRAWN BY: PJ
 2010 SERIES OPTIONAL STRAINER HEADS
 FIGURE NUMBER

ASSUME NO RESPONSIBILITY OR USE OF SUPERSEDED OR VOID DATA
 DIMENSIONS ARE SUBJECT TO MANUFACTURERS TOLERANCE AND CHANGE WITHOUT NOTICE

OPTIONAL STRAINER HEADS

ROUND STRAINER

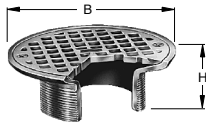

MATERIALS:
 Chrome Plated -CP
 Polished Bronze -PB
 Nickel Bronze -NB
 Stainless Steel
 Strainers -SS [Available in 05(125) & 06(150) sizes only]

VARIATIONS:
 •Hinged Grate (Specify Suffix -AH)
 Sediment Bucket -B
 Vandal Proof Screws -U

B DIA	05 (125)	06 (150)	07 (180)	08 (205)	09 (230)	10 (255)
H	2 (51)	2 (51)	2 1/4 (57)	2 1/2 (64)	2 1/2 (64)	2 3/4 (70)
X MIN	1 1/4 (32)	1 1/4 (32)	1 1/4 (32)	1 1/2 (38)	1 1/2 (38)	1 1/2 (38)
X MAX	2 1/4 (57)	2 1/4 (57)	2 1/4 (57)	2 1/2 (64)	2 1/2 (64)	2 3/4 (70)

LIGHT DUTY

SUFFIX -A

Specify Type, Size & Finish eg: A05NB
 *Not available for 05" (125) size

SQUARE STRAINER

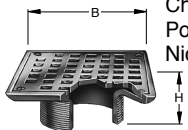

MATERIALS:
 Chrome Plated -CP
 Polished Bronze -PB
 Nickel Bronze -NB

VARIATIONS:
 Flapper Type Backwater Valve (Specify Suffix -BV) 05 (125), 06 (150), 07 (180) or 08" (205) sizes only
 *Hinged Grate (Specify Suffix -BH)
 Sediment Bucket -B
 Vandal Proof Screws -U

B SQ	05 (125)	06 (150)	07 (180)	08 (205)	09 (230)	10 (255)
H	2 (51)	2 (51)	2 1/4 (57)	2 1/2 (64)	2 1/4 (57)	2 1/4 (57)
X MIN	1 1/4 (32)	1 1/4 (32)	1 1/4 (32)	1 1/2 (38)	1 1/2 (38)	1 1/2 (38)
X MAX	2 1/4 (57)	2 1/4 (57)	2 1/4 (57)	2 1/2 (64)	2 1/4 (57)	2 3/8 (60)

LIGHT DUTY

SUFFIX -B

Specify Type, Size & Finish eg: B05NB
 *Not available for 05" (125) size

REINFORCED ROUND STRAINER

FUNCTION: Used in finished floors where light wheeled loads are anticipated.

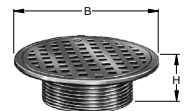

MATERIALS:
 Chrome Plated -CP
 Polished Bronze -PB
 Nickel Bronze -NB

VARIATIONS:
 Flapper Type Backwater Valve (Specify Suffix -CV)
 Sediment Bucket -B
 Vandal Proof Screws -U

B DIA	05 (125)	06 (150)	08 (205)	10 (255)
H	2 (51)	2 (51)	2 1/2 (64)	2 3/4 (70)
MIN	1 1/4 (32)	1 1/4 (32)	1 1/2 (38)	1 7/8 (48)
MAX	2 1/4 (57)	2 1/4 (57)	2 1/2 (64)	2 3/4 (70)

LIGHT DUTY

SUFFIX -C

Specify Type, Size & Finish eg: C06NB

TILE FLANGE

FUNCTION: Provides integral flange set 5/32"(4) below rim to receive floor covering. Flange may have option of tapped holes for securing pan and gasket.

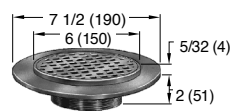

MATERIALS:
 Chrome Plated -CP
 Polished Bronze -PB
 Nickel Bronze -NB

VARIATIONS:
 Flapper Type Backwater Valve (Specify Suffix -FV)
 Holes in Flange -SH
 Sediment Bucket -B
 Vandal Proof Screws -U

	X
MIN	MAX
1 1/4 (32)	2 1/8 (54)

LIGHT DUTY

SUFFIX -F

Specify Type, Size & Finish eg: F06NB

FLAPPER TYPE BACKWATER VALVE

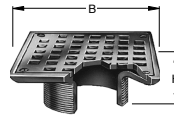

FUNCTION: Provides backwater protection at point where protection is needed.

MATERIALS:
 Chrome Plated -CP
 Polished Bronze -PB
 Nickel Bronze -NB

VARIATIONS:
 •Hinged Grate (Specify Suffix -AH)
 Vandal Proof Screws -U

B SQ	05 (125)	06 (150)	07 (180)	08 (205)
H	2 (51)	2 (51)	2 1/4 (57)	2 1/2 (64)
X MIN	1 1/4 (32)	1 1/4 (32)	1 1/4 (32)	1 1/2 (38)
X MAX	2 1/4 (57)	2 1/4 (57)	2 1/4 (57)	2 1/2 (64)

LIGHT DUTY

SUFFIX -AV

Specify Type, Size & Finish eg: AV05NB
 *Not available for 05" (125) size

STRAINER HEAD w/SQUARE HINGED COVER

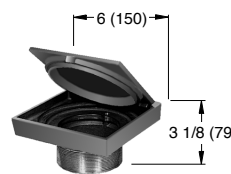

MATERIALS:
 Chrome Plated -CP
 Polished Bronze -PB
 Nickel Bronze -NB

VARIATIONS:
 Gasketed Water Tight Cover -GC
 Secured Cover -SC
 Secondary Strainer Grate-SG

LIGHT DUTY

SUFFIX -BS

Specify Type, Size & Finish eg: BSNB

REINFORCED TRACTOR STRAINER

FUNCTION: Used in finished floors where light weight wheeled loads are anticipated and loose set non-tilt tractor grate is desired.



MATERIALS:
 Cast Iron -CI
 Chrome Plated -CP
 Polished Bronze -PB
 Nickel Bronze -NB

VARIATIONS:
 Flapper Type Backwater Valve (Specify Suffix -DV or -EV)
 Sediment Bucket -B
 Vandal Proof Screws -U

SUFFIX	B DIA	H	X	
-D	07 (180)	3 1/4 (83)	2 5/8 (67)	3 1/2 (89)
-E	09 (230)	3 1/2 (89)	2 3/4 (70)	3 1/2 (89)

LIGHT DUTY

SUFFIX -D-E

Specify Type, Size & Finish eg: D09PB
 E09PB

ADJUSTABLE STRAINER HEAD

FUNCTION: Used in a non-traffic area when a funnel type strainer head is required and space does not allow use of the 3500 series funnel. The extended rim allows use as an anti-flood and anti-splash drip pan.

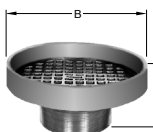

VARIATIONS:
 Flapper Type Backwater Valve (Specify Suffix -F37V or F38V)

MATERIALS:
 Cast Iron -CI
 Chrome Plated -CP
 Galvanized Cast Iron -G
 Polished Bronze -PB
 Nickel Bronze -NB

SUFFIX	-F37	-F38
B DIA	07 (180)	09 (230)
H	3 1/4 (83)	3 1/2 (89)
X MIN	2 5/8 (67)	2 3/4 (70)
X MAX	3 1/2 (89)	3 1/2 (89)

NON-TRAFFIC

SUFFIX -F37-F38

Specify Type, Size & Finish eg: F37NB F38CP

REV.	DATE	DESCRIPTION	BY	CKD. BY	FIGURE NUMBER
K	7-29-19	Added Load Rating(s)	MW	JM	2010 SERIES OPTIONAL STRAINER HEADS 1 of 2
J	6-18-19	Revised DIA to SQ Suf -AV, -B	TBW	TK	
H	11-3-16	Revised Suffix-A	TBW	CL	
G	10-4-01	Revised Suffix-BS	RN	CL	

NOTE: Dimensions shown in parentheses are in millimeters.

OPTIONAL STRAINER HEADS

DRAWING NUMBER: PM0457 SH 2 of 2
 SIZE: A
 SCALE: NONE
 DATE: 5-17-85
 APPROVED BY: TD
 CHECKED BY: TD
 DRAWN BY: PJ
 2010 SERIES OPTIONAL STRAINER HEADS

ASSUME NO RESPONSIBILITY OR USE OF SUPERSEDED OR VOID DATA
 DIMENSIONS ARE SUBJECT TO MANUFACTURERS TOLERANCE AND CHANGE WITHOUT NOTICE

LOW DOME STRAINER

FUNCTION: Used in gutters and recessed areas where excessive debris build-up is expected. Dome insures drainage even when partly covered.

MATERIALS:
 Chrome Plated -CP
 Polished Bronze -PB
 Nickel Bronze -NB

VARIATIONS:
 Flapper Type Backwater Valve (Specify Suffix -GV)
 Sediment Bucket -B
 Vandal Proof Screws -U



B DIA	05 (125)	06 (150)	08 (205)
H	2 (51)	2 (51)	2 1/2 (64)
MIN	1 1/4 (32)	1 1/4 (32)	1 1/2 (38)
MAX	2 1/4 (57)	2 1/4 (57)	2 1/2 (64)

SUFFIX -G Specify Type, Size & Finish eg: G08PB

SOLID HINGED COVER

FUNCTION: Used in areas where intermittent drain use is required. Solid cover prevents intrusion of chips, saw-dust, etc., which are swept up before cover is opened for washdown. The secondary strainer prevents debris from entering the waste line.

MATERIALS:
 Chrome Plated -CP
 Polished Bronze -PB
 Nickel Bronze -NB

VARIATIONS:
 Flapper Type Backwater Valve (Specify Suffix -GV)
 Vandal Proof Screws -U



B DIA	05 (125)	06 (150)	07 (180)	08 (205)
H	2 (51)	2 (51)	2 1/4 (57)	2 1/2 (64)
X MIN	1 1/4 (32)	1 1/4 (32)	1 1/4 (32)	1 1/2 (38)
MAX	2 1/4 (57)	2 1/4 (57)	2 1/4 (57)	2 1/2 (64)

SUFFIX -H Specify Type, Size & Finish eg: H05CP

SPANNER WRENCH COVER

FUNCTION: Solid gas tight, vandal proof, threaded cover for areas where intermittent drain use is required.

MATERIALS:
 Chrome Plated -CP
 Polished Bronze -PB
 Nickel Bronze -NB

VARIATIONS:
 Flapper Type Backwater Valve (Specify Suffix -JV)
 Sediment Bucket -B

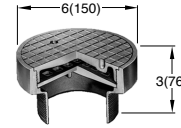

MEDIUM DUTY	
X	
MIN	2 (51)
MAX	3 (76)

SUFFIX -J Specify Type, Size & Finish eg: J06NB

REINFORCED SQUARE STRAINER

FUNCTION: Used in finished floors where some light wheeled traffic is anticipated.

MATERIALS:
 Chrome Plated -CP
 Polished Bronze -PB
 Nickel Bronze -NB

VARIATIONS:
 Flapper Type Backwater Valve (Specify Suffix -KV)
 Sediment Bucket -B
 Vandal Proof Screws -U

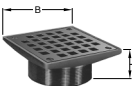

B SQ	05 (125)	06 (150)	07 (180)	08 (205)
H	2 (51)	2 (51)	2 1/4 (57)	2 1/2 (64)
X MIN	1 1/4 (32)	1 1/4 (32)	1 1/4 (32)	1 1/2 (38)
MAX	2 1/4 (57)	2 1/4 (57)	2 1/4 (57)	2 1/2 (64)

SUFFIX -K Specify Type, Size & Finish eg: K07CP

RECTANGULAR STRAINER

FUNCTION: Used in finished floors where light wheeled loads and or heavy foot traffic are anticipated.

MATERIALS:
 Chrome Plated -CP
 Polished Bronze -PB
 Nickel Bronze -NB

VARIATIONS:
 Sediment Bucket -B
 Vandal Proof Screws -U

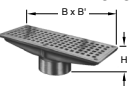

SUFFIX	L	M	N	P	R	T
B x B'	4 1/2 (115)	8 (205)	11 (280)	13 (330)	15 (380)	17 (430)
H	2 1/4 (57)	2 1/2 (64)	2 1/4 (57)	3 (76)	2 1/4 (57)	3 (76)
X MIN	1 3/8 (35)	1 7/8 (48)	1 3/8 (35)	2 1/8 (54)	1 3/8 (35)	2 1/4 (57)
MAX	2 3/8 (60)	2 3/4 (70)	2 3/8 (60)	3 (76)	2 3/8 (60)	3 1/8 (79)

SUFFIX -L-M-N-P-R-T Specify Type, Size & Finish eg: LNB

ANGLE STRAINER

FUNCTION: Shower room drain set at wall and floor junction. Vertical grate openings prevent drain stoppage should flat surface become covered.

MATERIALS:
 Chrome Plated -CP
 Polished Bronze -PB
 Nickel Bronze -NB

VARIATIONS:
 Vandal Proof Screws -U

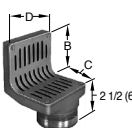

SUFFIX	B	C	D	X	
-V	3 1/2 (89)	3 1/2 (89)	4 1/2 (115)	1 5/8 (41)	2 5/8 (67)
-W	6 3/4 (170)	6 3/4 (170)	6 1/2 (165)	1 5/8 (41)	2 5/8 (67)

SUFFIX -V-W Specify Type, Size & Finish eg: VPB, WNB

EXTENSION ADAPTOR

FUNCTION: Used when a strainer head must be raised to accommodate deeper floor fill.

REGULARLY FURNISHED:
 Duco Cast Iron -CI

MATERIALS:
 Cast Bronze -CB
 Galvanized Cast Iron -G

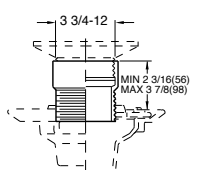

NOTE: Extension can be stacked for increased maximum adjustment.

SUFFIX -X

OVERFLOW WITH STANDPIPE

FUNCTION: Used as overflow drain in decorative pools, fish ponds or similar areas. Dome prevents floating objects from entering drain line.

MATERIALS:
 Chrome Plated -CP
 Nickel Bronze -NB
 Polished Bronze -PB

VARIATIONS:
 Less Dome -LD
 Standpipe Height other than 6" (150) (Specify Height)

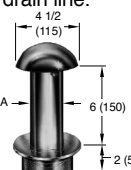

SUFFIX	A	X	
SIZE	MIN	MAX	
-Y	2 (51)	3/4 (19)	2 1/8 (54)
-Z	3 (76)	3/4 (19)	2 1/8 (54)

SUFFIX -Y-Z Specify Type, Size & Finish eg: YCP, ZCP

HEAVY DUTY ADJUSTABLE

FUNCTION: Used in finished floors where light wheeled loads and or heavy foot traffic are anticipated.

MATERIALS:
 Polished Bronze -PB
 Rough Bronze -RB
 Nickel Bronze -NB

VARIATIONS:
 Flapper Type Backwater Valve (Specify Suffix -69V)
 Sediment Bucket -B
 Vandal Proof Screws -U

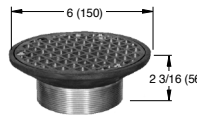

SUFFIX -69 eg: A06NB-69

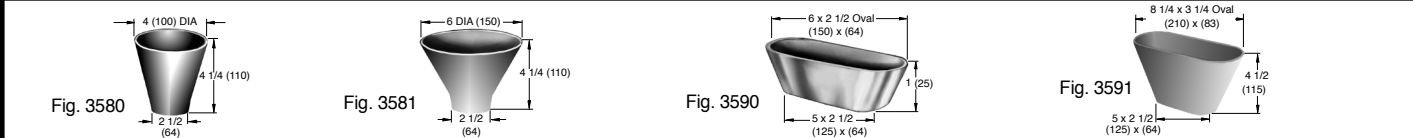

L	7-29-19	Added Load Rating(s) Rev. Materials Suffix -H, -V-W Rev. Variations of Suffix -J Revised Revised Tables	MW	JM	FIGURE NUMBER 2010 SERIES OPTIONAL STRAINER HEADS 2 of 2
K	10-20-17		TBW	CL	
J	1-17-12		TBW	AM	
H	8-24-99		TBW	BS	
G	6-11-99		CMD		
REV.	DATE	DESCRIPTION	BY	CKD. BY	

NOTE: Dimensions shown in parentheses are in millimeters.

WARNING: Cancer and Reproductive Harm - www.P65Warnings.ca.gov