

Location: _____



F1490

FLOOR DRAIN WITH 15 3/4" SQUARE HEAVY DUTY TRACTOR GRATE AND DEEP SUMP

Specification: MIFAB® Series F1490 epoxy coated large capacity floor drain with deep sump body, and standard 1" (25) thick, 15 3/4" (406) square, (specify material finish) tractor grate with free area of 75 square inches.

Function: Used in industrial factories, mechanical rooms, parking garages and other non-membrane finished areas. 15 3/4" square tractor grate is used with all types of poured finished floors. Hinged grate permits easy access to sediment bucket.

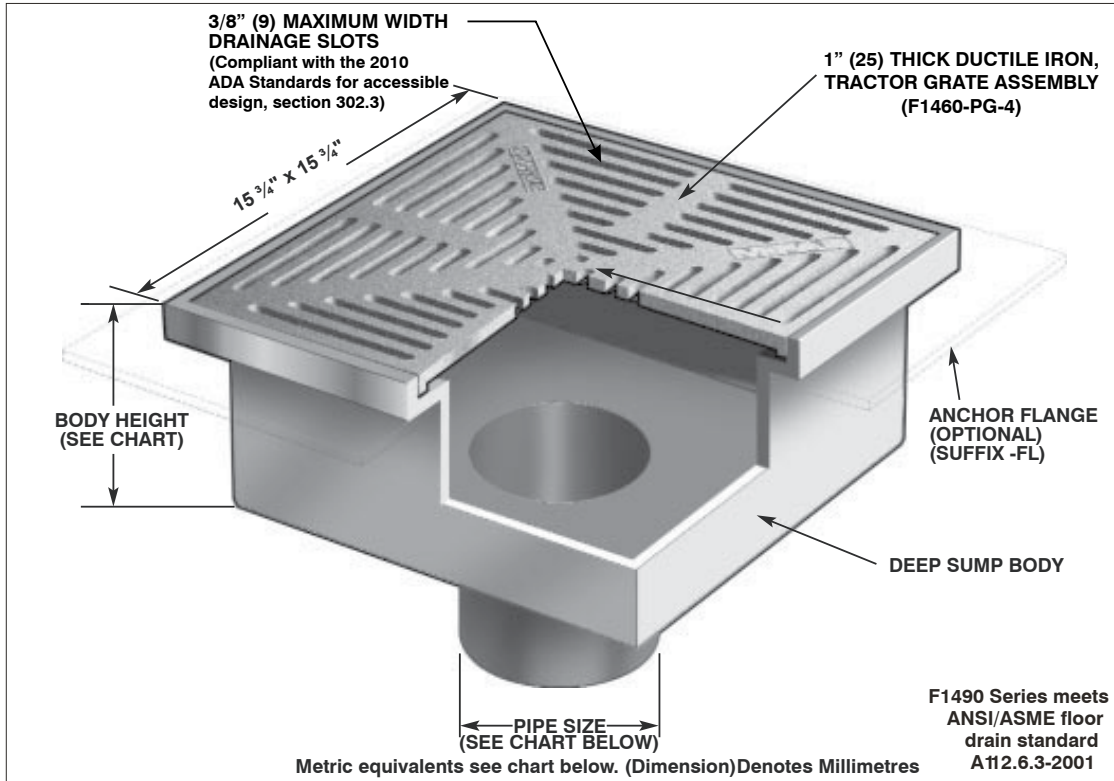

STRAINER DIAMETER	ANSI/ASME RATING		PIPE SIZE	BODY HEIGHT			
	FREE AREA	LOAD RATING		NO HUB (STANDARD)	PUSH ON (P)	THREADED (T)	INSIDE CAULK (X)
15 3/4" x 15 3/4" (406 x 406)	75 in ²	N.B. (-1) / S.S. (-3) / D.I. (-4)	2" (51)	11" (280)	11 3/4" (289)	10" (254)	11" (280)
		ANSI/ASME LOAD CLASS "SPECIAL DUTY" (OVER 10,000 LBS.)	3" (76)	11" (280)	11 3/4" (289)	10" (254)	11" (280)
			4" (102)	11" (280)	11 3/4" (289)	10" (254)	11" (280)
			6" (152)	11" (280)	11 3/4" (289)	10" (254)	11" (280)

- SUFFIX OPTIONAL VARIATIONS**
- 1 Nickel bronze strainer (vener)
 - 3 Stainless steel strainer (vener)
 - 4 Ductile iron strainer
 - 5 Sediment bucket
 - 6 Security screws (T-20 Torx & pin)
 - 7 1/2" trap seal primer connection
 - 8 Backwater valve (2", 3", 4")
 - 11 Acid resistant epoxy coated body
 - 13 Galvanized body
 - 20 Secondary dome strainer
 - 21 Secondary flat stainless steel strainer (2", 3", 4")
 - 22 Less grate
 - 28 Stainless steel body and grate (Type 304)

- SUFFIX OPTIONAL VARIATIONS**
- 90 Threaded side outlet (2", 3", 4")
 - 90NH No hub side outlet (2", 3", 4")
 - BA Buy American Act compliant product
 - C Membrane clamp
 - FL Anchor flange
 - HP Heel proof grate (1/4" maximum grate opening size, -3 only)
 - (Standard) No hub outlet
 - MG MI-GARD Floor Drain Trap Sealer (2", 3" or 4")
 - P Push on outlet
 - PA Pennsylvania Steel Act compliant product
 - T Threaded outlet (2", 3", 4")
 - X Inside caulk outlet

Job Name: _____ Page No: _____

Section No: _____ Contractor: _____

Schedule No: _____ Purchase Order No: _____