



Semi-Recessed Bottle Fillers

INSTALLATION/MAINTENANCE INSTRUCTIONS

BF38 & BF48 Series Semi-Recessed Bottle Filler With Chiller



**TECHNICAL ASSISTANCE TOLL FREE TELEPHONE NUMBER:
1.800.591.9360**

Technical Assistance Fax: 1.626.855.4894

NOTES TO INSTALLER:

1. Please leave this documentation with the owner of the fixture when finished.
2. Please read this entire booklet before beginning the installation.
3. Check your installation for compliance with plumbing, electrical and other applicable codes.

LIMITED WARRANTY - UNITED STATES & CANADA

Murdock warrants that every cooler, bottle filling station, packaged water chiller, fountain and accessory to be free from defects in material and workmanship under normal use for one (1) year from date of install or eighteen (18) months after the date of shipment from the factory, whichever comes first.

Murdock warrants the compressor and hermetically sealed refrigeration system, including cooling coil assembly when part of the hermetically sealed refrigeration system, to be free from defects in material and workmanship under normal use for an additional four (4) years from the end of the one (1) year period described above.

This warranty does not cover installation or labor charges and does not apply to materials, which have been damaged by other causes such as mishandling or improper care or abnormal use. The repair or replacement of the defective materials shall constitute the sole remedy of the Buyer and the sole remedy of Murdock under this warranty. Murdock shall not be liable under any circumstances for incidental, consequential or direct charges caused by defects in the materials, or any delay in the repair or replacement thereof. This warranty is in lieu of all other warranties expressed or implied. Product maintenance instructions are issued with each unit and disregard or non-compliance with these instructions will constitute an abnormal use condition and void the warranty. Stainless steel must be protected on job site during construction and must be properly maintained after the water has been introduced into the water cooler or drinking fountain, or Murdock's limited warranty is void.

LIMITED EXPORT WARRANTY - One year on parts only.

Murdock™ assumes no responsibility for use of void or superseded data. © Copyright Murdock Mfg., City of Industry, CA Member of Morris Group International. Please visit www.murdockmfg.com for most current specifications.

COMPLIES WITH
STANDARDS



Member of
MORRIS GROUP
INTERNATIONAL

MURDOCK
15125 Proctor Ave.
City of Industry, CA
91746 U.S.A.
Phone 800-591-9360
626-336-4561
Fax 626-855-4894

www.murdockmfg.com

BF38 ROUGHING-IN AND DIMENSIONAL DRAWING

Prior to roughing in consult with local, state, and federal codes for proper installation.

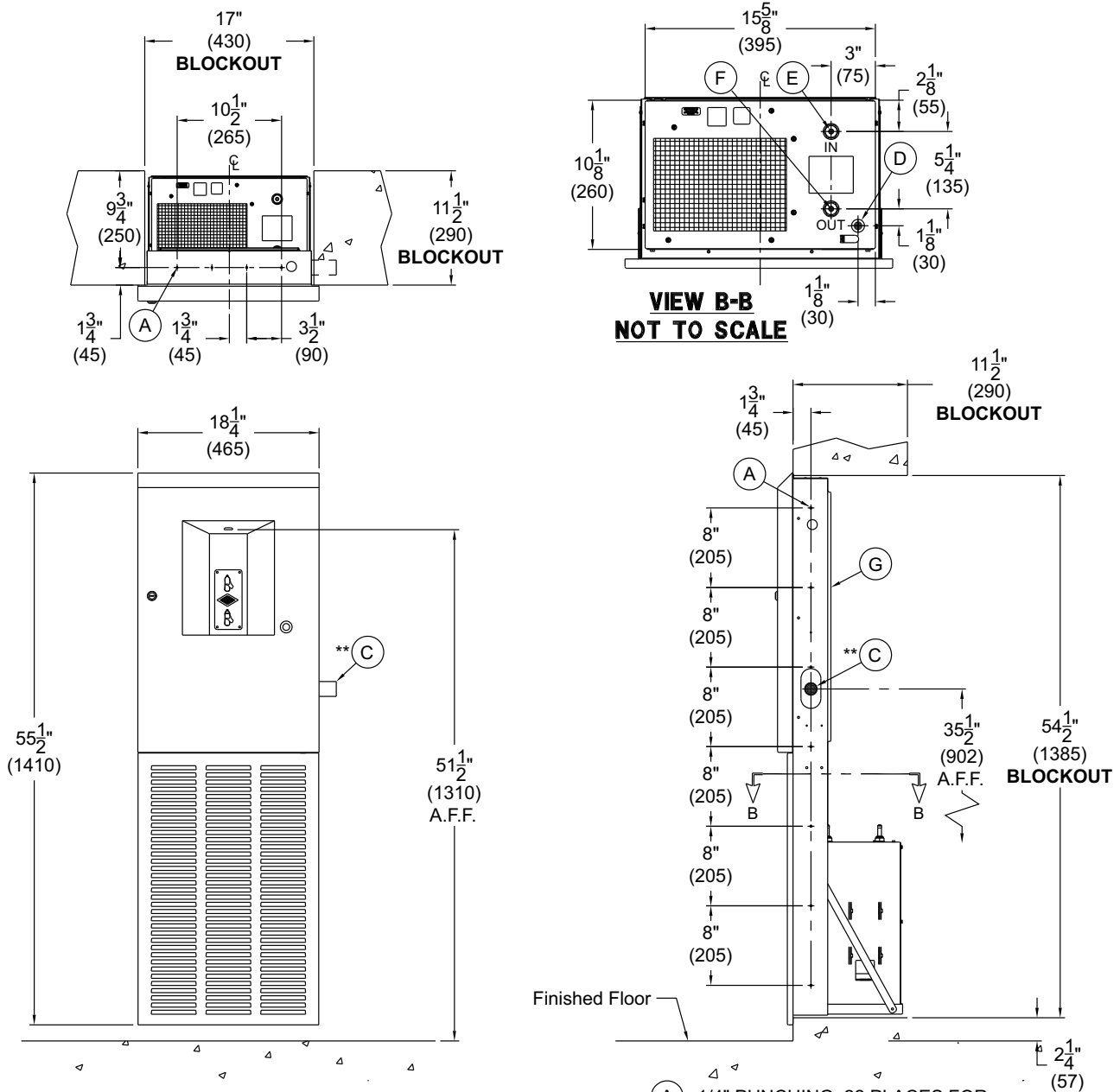

GENERAL DIMENSIONS:
 1. ALL DIMENSIONS ARE IN INCHES (MM)
 2. STOP VALVE NOT PROVIDED

NOTE: RIGHT, LEFT, AND REAR WASTE ORIENTATION ARE OPTIONAL IF NEEDED FOR CALLOUTS INDICATED **.

- (A) 1/4" PUNCHING, 22 PLACES FOR ANCHORING HARDWARE BY OTHERS
- (B) 3/8" OD COPPER SUPPLY INLET
- (C) 1-1/4" O.D. WASTE OUTLET
- (D) ELECTRICAL SERVICE ROUGH
- (E) 3/8" OD COPPER SUPPLY INLET (CHILLER)
- (F) 3/8" OD COPPER SUPPLY OUTLET (CHILLER)
- (G) -MF10 MOUNTING FRAME ASSEMBLY



Semi-Recessed Bottle Fillers

INSTALLATION/MAINTENANCE INSTRUCTIONS

BF48 ROUGHING-IN AND DIMENSIONAL DRAWING

Prior to roughing in consult with local, state, and federal codes for proper installation.

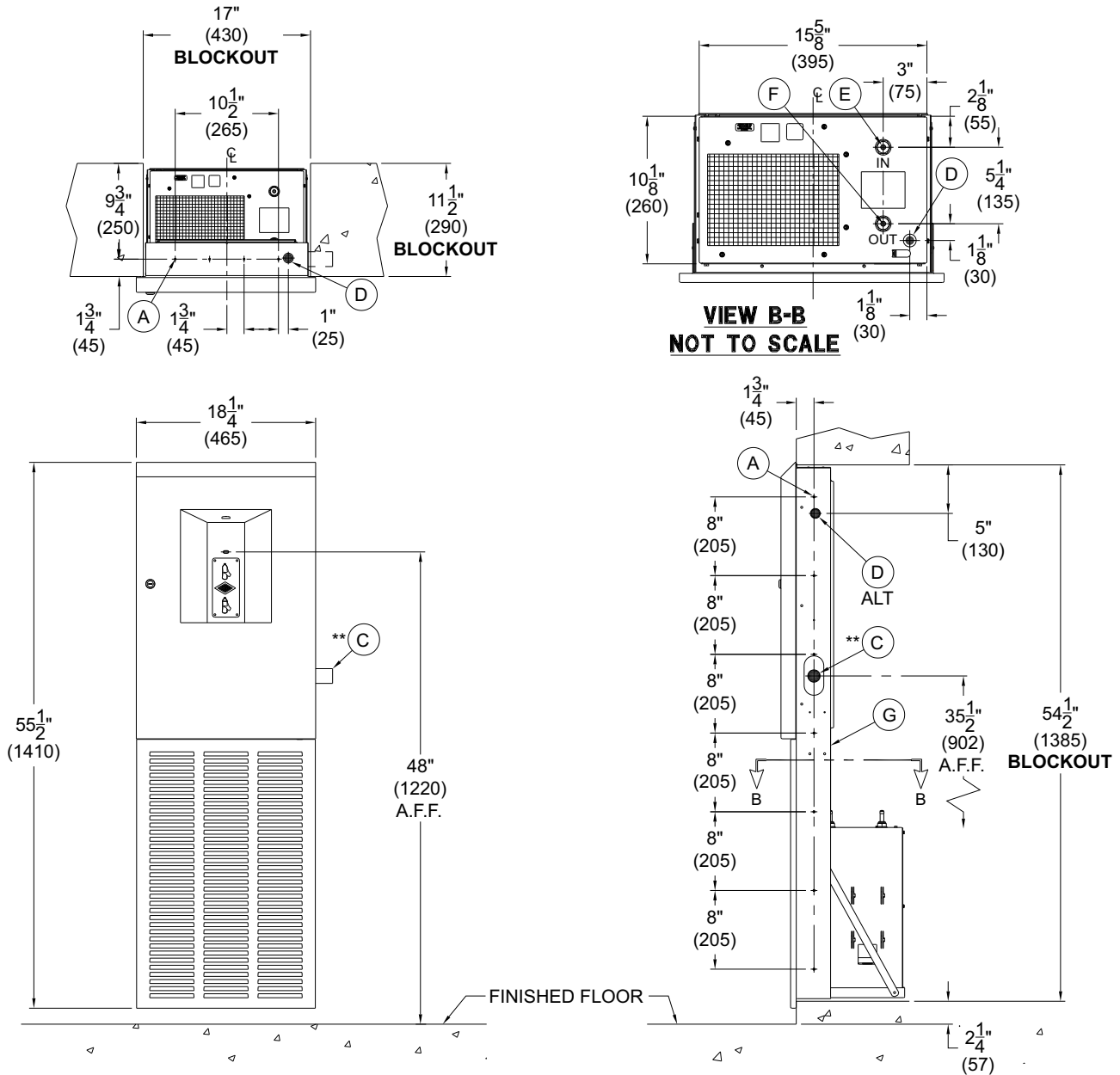

GENERAL DIMENSIONS:
 1. ALL DIMENSIONS ARE IN INCHES (MM)
 2. STOP VALVE NOT PROVIDED

NOTE: RIGHT, LEFT, AND REAR WASTE ORIENTATION ARE OPTIONAL IF NEEDED FOR CALLOUTS INDICATED **.

- (A) 1/4" PUNCHING, 22 PLACES FOR ANCHORING HARDWARE BY OTHERS
- (B) 3/8" OD COPPER SUPPLY INLET
- (C) 1-1/4" O.D. WASTE OUTLET
- (D) ELECTRICAL SERVICE ROUGH
- (E) 3/8" OD COPPER SUPPLY INLET (CHILLER)
- (F) 3/8" OD COPPER SUPPLY OUTLET (CHILLER)
- (G) -MF10 MOUNTING FRAME ASSEMBLY

PRIOR TO INSTALLATION:

1. Read all installation instructions carefully, before proceeding.
2. Carefully remove all fixture components from packaging, preventing scratching or damage.
3. Provide mounting surface, sufficient to support the fixture and loads on the fixture.
4. Provide rough-ins as shown on the roughing-in and dimensional drawing, including water supply, drain pipe and gravel drain well. (See pages 2 or 3 for rough-in details)
5. On the semi-recessed bottler filler assembly, unlock and swing open the hinged door assembly to expose internal components. Disconnect 1/4" O.D. polyethylene tube connection from the hinged door assembly. Then remove the hinged door assembly from mounting frame by unlatching insert clip hinges.
6. Completely flush water supply lines of all foreign debris, before connecting to the fixture.

INSTALLATION: (see drainage & mounting roughing-in pg. 2 or 3)

1. Insert MF10 Frame assembly into the rough-in block out and secure using 1/4"-20 UNC mounting hardware (Provided by others)
2. Using #10-32 x 1/2" Hex Btn Screws provided mount bottle filler mounting frame to the MF10 frame assembly.
3. Place the Chiller Unit onto the basepan of the MF10 Frame Assembly.
4. Make up the 3/8" O.D. Copper inlet supply connection to chiller and Bottle Filler.
5. Loosen slip nuts to orientate P-trap to desired direction then tighten slip nuts and make up 1-1/4" O.D. waste connection.
6. Attach hinged door assembly to mounting frame by latching insert clip hinges. Make necessary adjustments to hinges with the adjustment screw to prevent door from rubbing on wall when opening. Refer to door hinge adjustment detail below.
7. Make up all power connections to the ground, neutral & hot within the electrical box and chiller unit.
8. Install removable access panel using #10-32 x 1/2" provided.

NOTE: BEFORE PERFORMING STEP 9 REFER TO ELECTRICAL INSTALLATION ON PAGE 6.

9. Test for leaks and proper operation, and then install the door using the hinges provided.

HINGE ADJUSTMENT

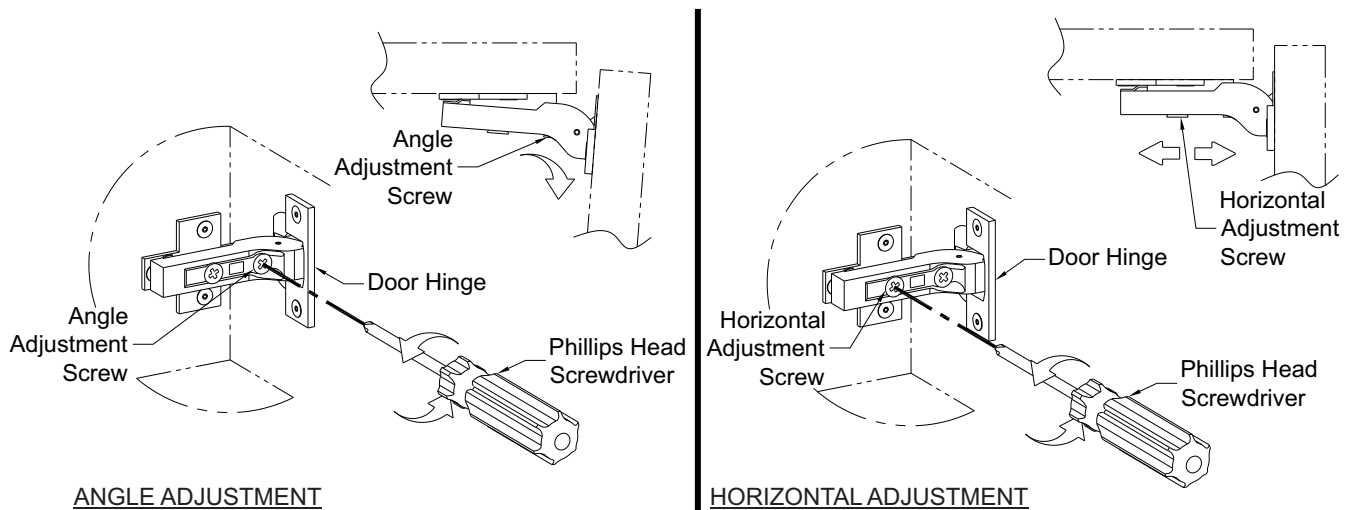



Semi-Recessed Bottle Fillers

INSTALLATION/MAINTENANCE INSTRUCTIONS

START UP:

Air within the bottle filler system or the structure supply piping will cause an irregular spout outlet stream until purged out by incoming water. Press and hold pushbutton until steady water stream is achieved.

SENSOR OPERATION INSTRUCTIONS:

Hold container to be filled just below the sensor in the center of the filler spout and then move the container upward and water flow will start automatically. When the container is almost filled, lower the container below the sensor until the water stops flowing. (see label on the bottle filler)

HAND OPERATION INSTRUCTIONS:

Hold container to be filled just below the filler tube in the center of the unit, then push pushbutton. When the container is almost filled, release the pushbutton.

WATER TUBING CONNECTIONS:

NOTE: Insulation on all water tubes not shown (all PE water tubes are insulated).

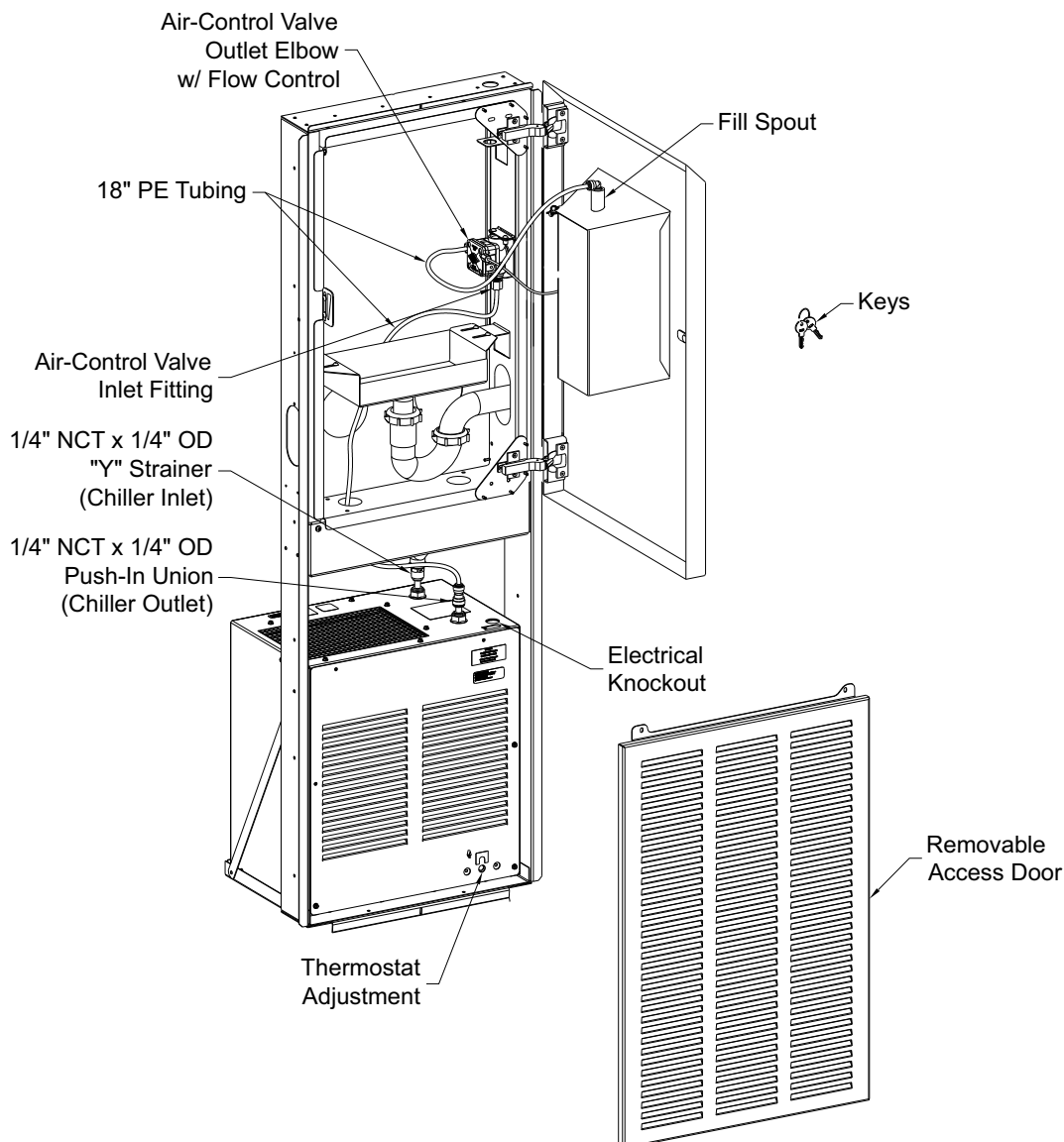



Semi-Recessed Bottle Fillers

INSTALLATION/MAINTENANCE INSTRUCTIONS

OPTIONAL -WF1 WATER FILTER

See the following page for models with -WF1 Water Filter (BF38-WF1 or BF48-WF1)

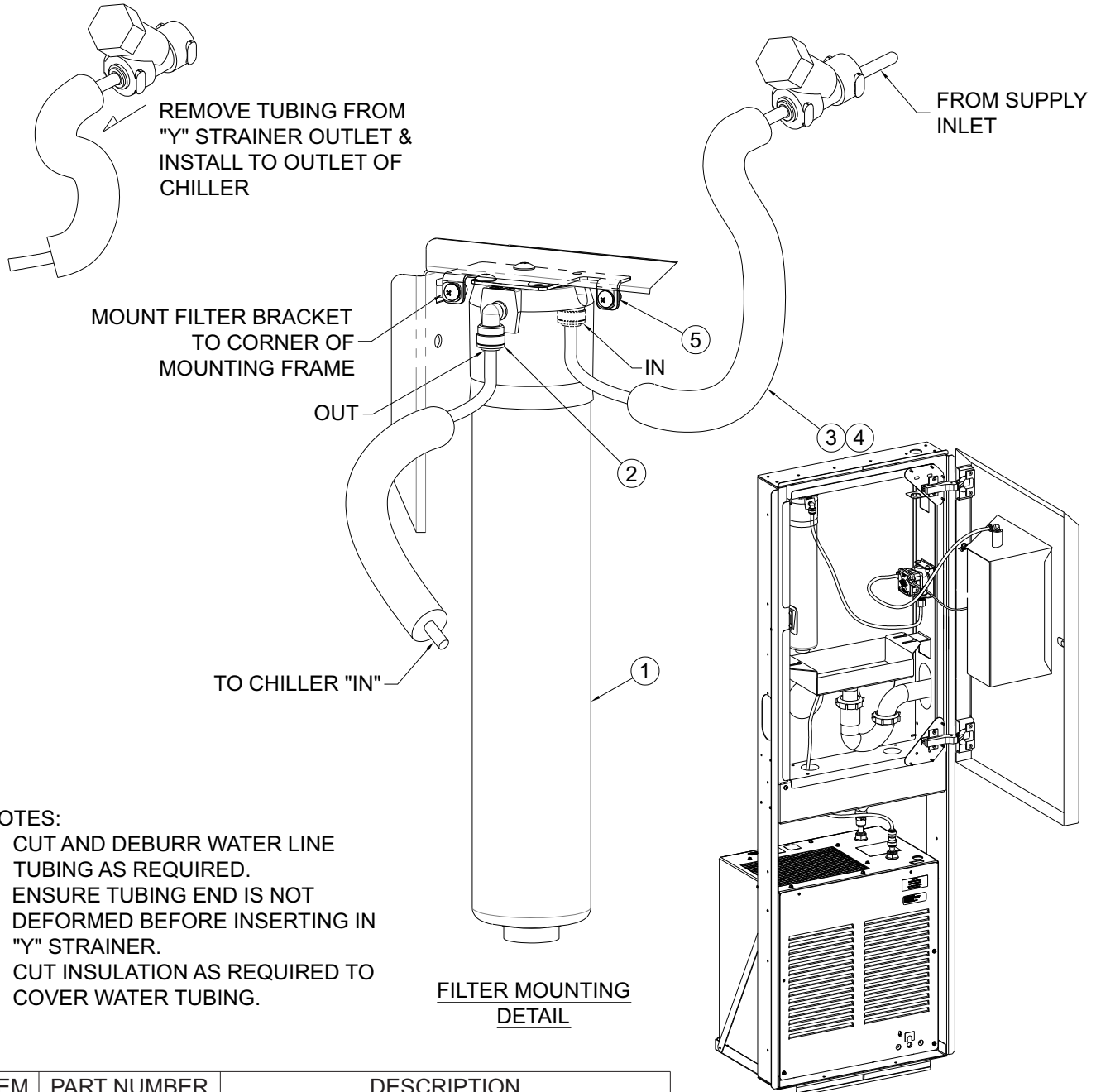

NOTES:

1. CUT AND DEBURR WATER LINE TUBING AS REQUIRED.
2. ENSURE TUBING END IS NOT DEFORMED BEFORE INSERTING IN "Y" STRAINER.
3. CUT INSULATION AS REQUIRED TO COVER WATER TUBING.

FILTER MOUNTING
DETAIL

INSTALLED FILTER DETAIL

ITEM	PART NUMBER	DESCRIPTION
1	7012-311-000	WF1 FILTER 1500 GALLONS
2	1895-709-000	ELBOW, PUSH-IN, 1/4" O.D. x 1/4" STEM
3	2169-000-000	1/4: O.D. LLDPE TUBING, BLUE
4	7012-055-000	FOAM PIPE INSULLATION
5	7003-670-001	FILTER BRACKET ASSEMBLY

OPTIONAL -WF1 WATER FILTER INSTALLATION

FILTER CARTRIDGE REPLACEMENT:

1. Unlock and swing open bottle filler door, this allows access to the filter and the inlet valve (provided by others). Turn valve knob 1/4 turn clockwise to close.
2. With the filter assembly secured on the unit, hold the cap firmly, turn the replaceable cartridge filter counterclockwise to remove.
3. Remove and replace the cartridge turning clockwise to secure.
4. Turn inlet 1/4 turn knob 1/4 turn counterclockwise to open and test for leaks and proper operation before re-mounting panel assembly to fixture.

Note: It is recommended to place Shut-Off near Filter for easy access.

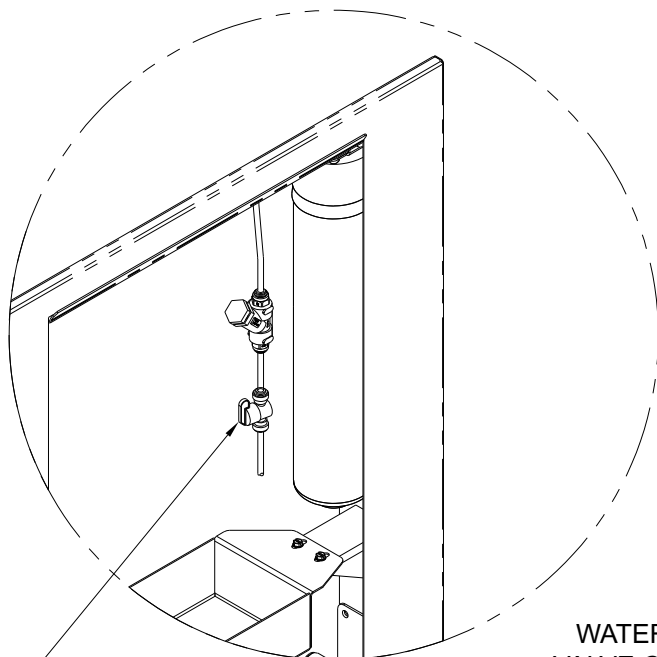
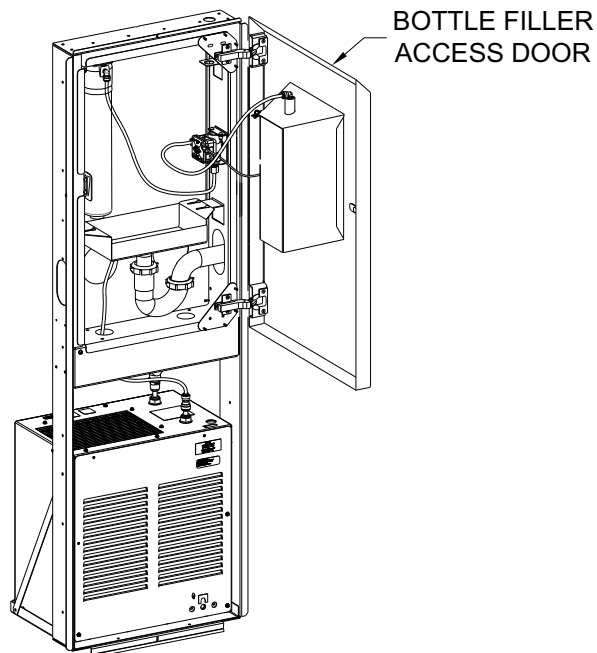

WATER INLET VALVE OPEN

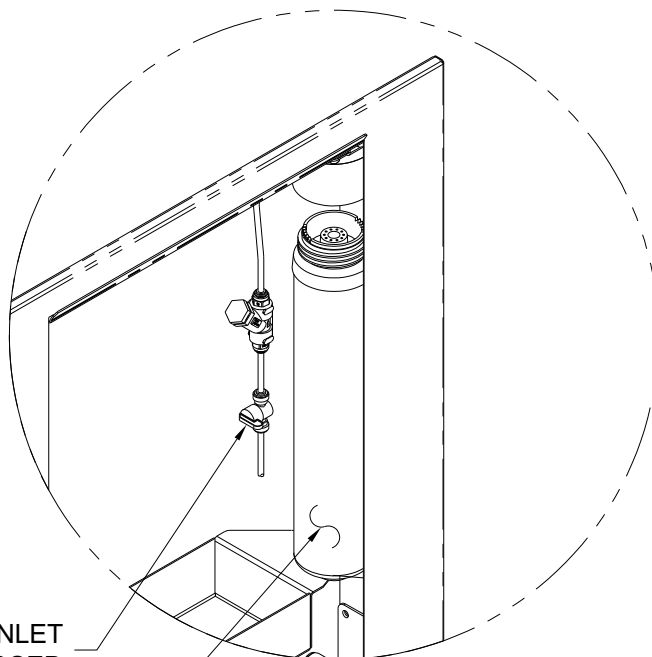

WATER INLET VALVE CLOSED

1



Semi-Recessed Bottle Fillers

INSTALLATION/MAINTENANCE INSTRUCTIONS

ELECTRICAL INSTALLATION:

NOTE: PLUG IN POWER IS A STANDARD FEATURE.

1A. Plug-In Operation: Plug transformer provided into GFCI protected electrical service, used by the semi-recessed bottle filler. Plug in transformer to power supply and connect to red sensor wire.

FOR -BAT BATTERY OPERATION OPTION.

1. -BAT Battery Operation: Peel off paper backing from hook & loop pads then press battery holder firmly in place. (See Ref. Below). Connect the battery holder wires to the red sensor wires. Unit requires six AA, alkaline or lithium batteries (not included). Note: When the battery holder is connected, the unit active.

2. Connect the blue sensor wires to the solenoid valve wires.(See Below)

TRANSFORMER WIRING AND WATER TUBING CONNECTIONS:

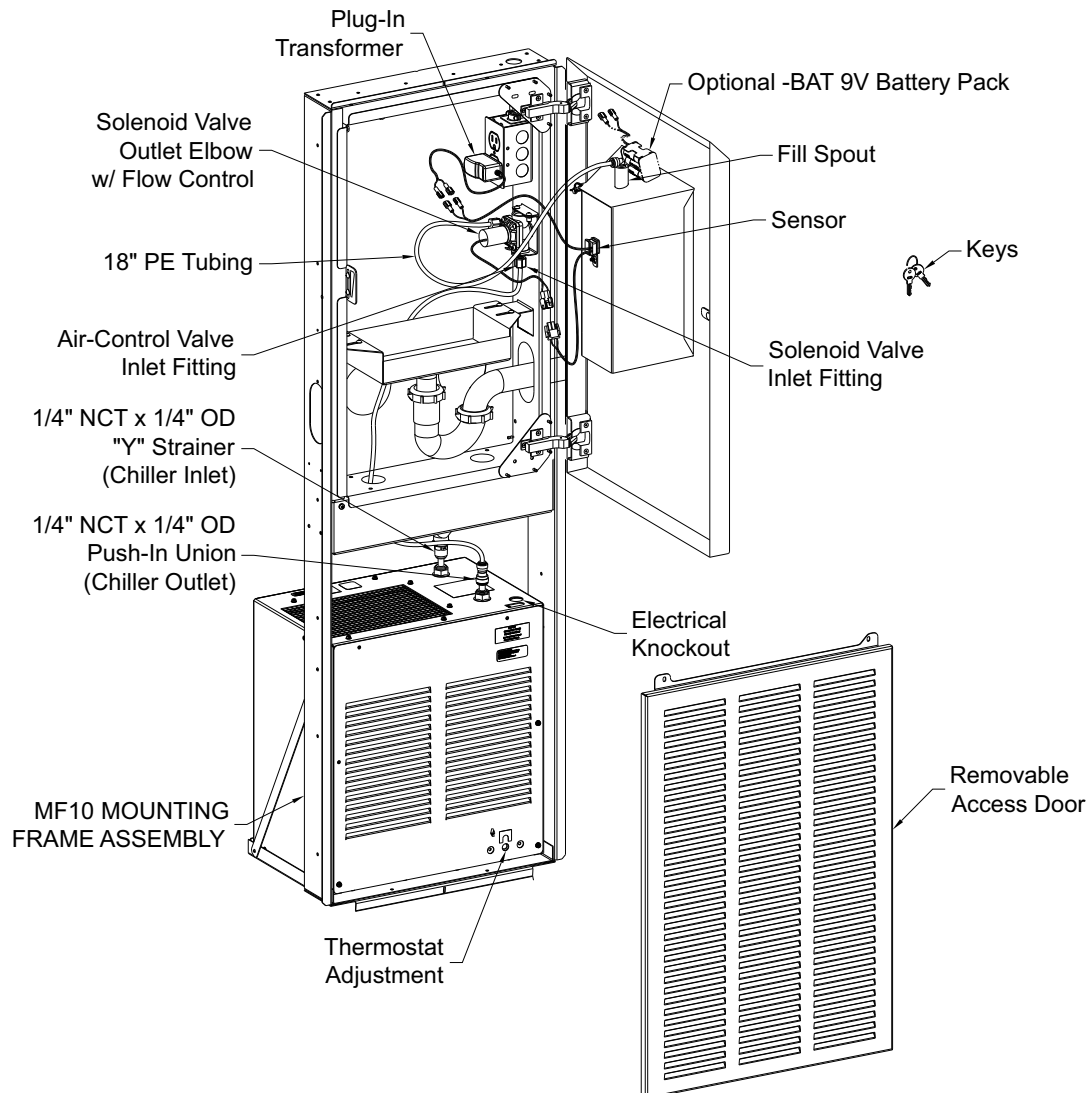



Semi-Recessed Bottle Fillers

INSTALLATION/MAINTENANCE INSTRUCTIONS

BOTTLE COUNTER ADJUSTING & RESETTING INSTRUCTIONS:

NOTE: Bottle Counter Has Multiple Functions

- Reset/ Mode Button
- Counts refilled bottles, otherwise purchased
- Adjustable for Units with and without filters
- “REPLACEMENT FILTER” alert function
- Alert reset, when filter is replaced

Description

Illuminated LCD display, counts bottles, and has a filter replacement alert function

Bottle Counting Function

The software applies a flow volume of approximately 16.9 fl oz (volume in standard size plastic water bottle) to each bottle counted. If the flow volume is less than 16.9 fl oz there will be no count but the volume will accumulate, so that part way through the next cycle the total bottle count will change.

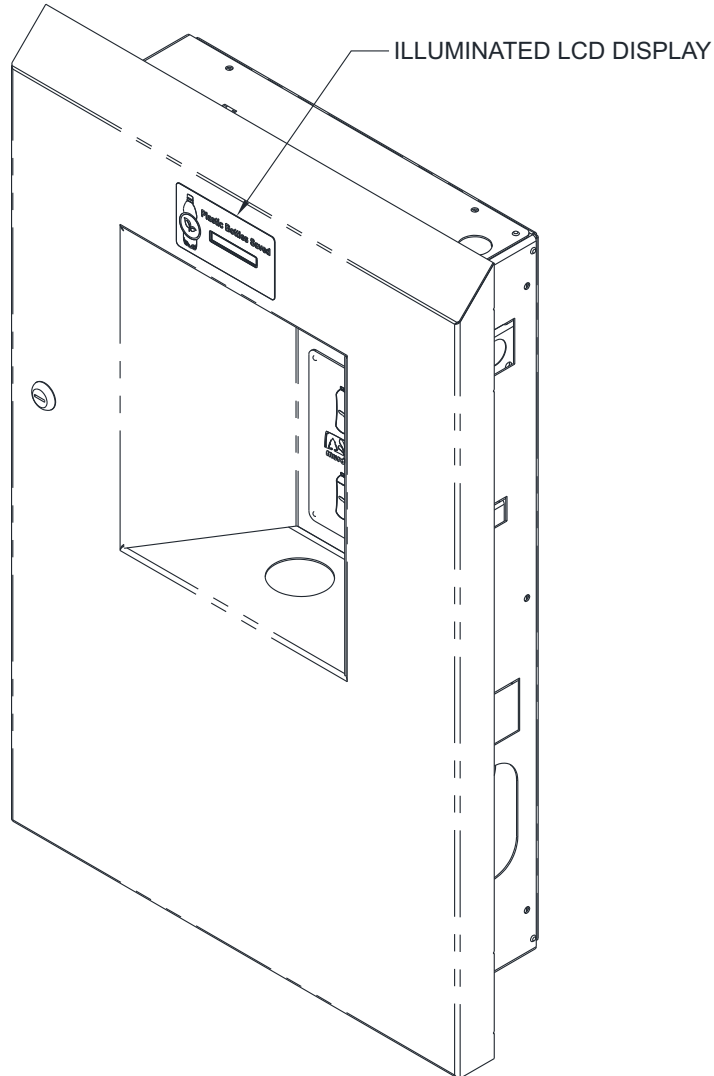



Semi-Recessed Bottle Fillers

INSTALLATION/MAINTENANCE INSTRUCTIONS

FILTER REPLACEMENT FUNCTIONS:

NOTE: When the volume accumulates to 1500 gallons (recommended maximum filter flow volume) the “REPLACE FILTER” alert will appear on the display every time the bottle filler is activated.

Counter Modes

Located on the back of the display you will find the reset button for the mode settings. The Reset/Mode selection button is accessible by removing the top of the bottle filler, then locate the large hole in the back of the display mounting bracket. Use your finger or nonconductive implement to depress the Reset/Mode Selection Button.

!!!DO NOT USE SHARP OR METAL IMPLEMENTS!!!

With this reset button, you are able to indicate whether or not the unit has a filter or does not have a filter. The reset button will also take away the “REPLACE FILTER” alert once the filter has been replaced.

Systems With or Without Filter

- Depress the Reset/Mode selection button for 6 Seconds, the number of seconds will count up on the display.
- At the end of the 6 seconds, “FLTR YES” or “FLTR NO” **WILL APPEAR** on the display.
- “FLTR YES” means that there is a filter in the system and a “REPLACE FILTER” alert **WILL APPEAR** on the display when the maximum filter flow volume is reached.
- “FLTR NO” means that there is no filter in the system and a “REPLACE FILTER” alert **WILL NOT APPEAR** on the display.
- Release button when the option required is on the display (Filter Yes or No)

CLEARING “REPLACE FILTER” ALERT:

NOTE: This Function only applies if the system as a filter

- Replace old filter with new filter.
- Depress the Reset/Mode selection button for **2 SECONDS**
- The “REPLACE FILTER” will no longer appear on the display
- Test by actuating the bottle filler, alert will not appear.

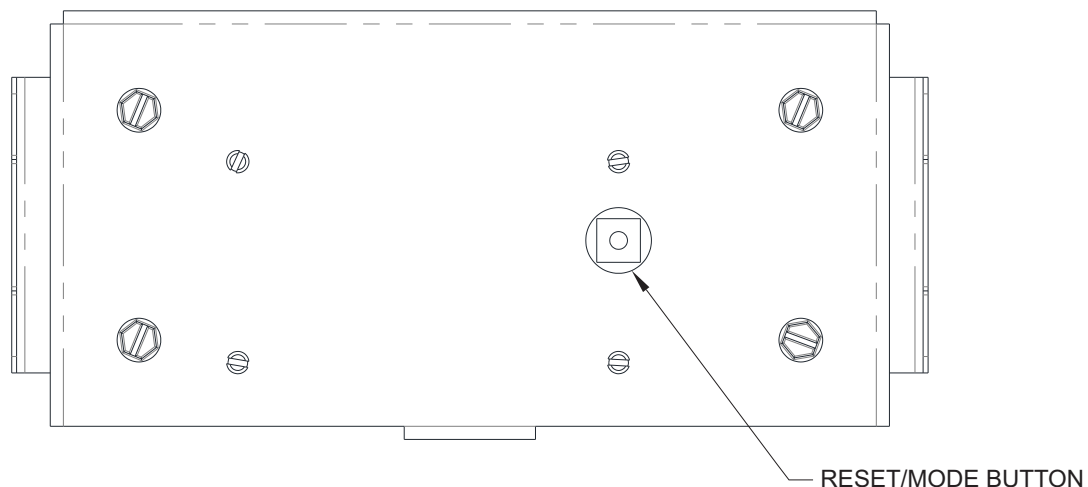



Semi-Recessed Bottle Fillers

INSTALLATION/MAINTENANCE INSTRUCTIONS

BOTTLE FILLER & BOTTLE COUNTER CONNECTIONS:

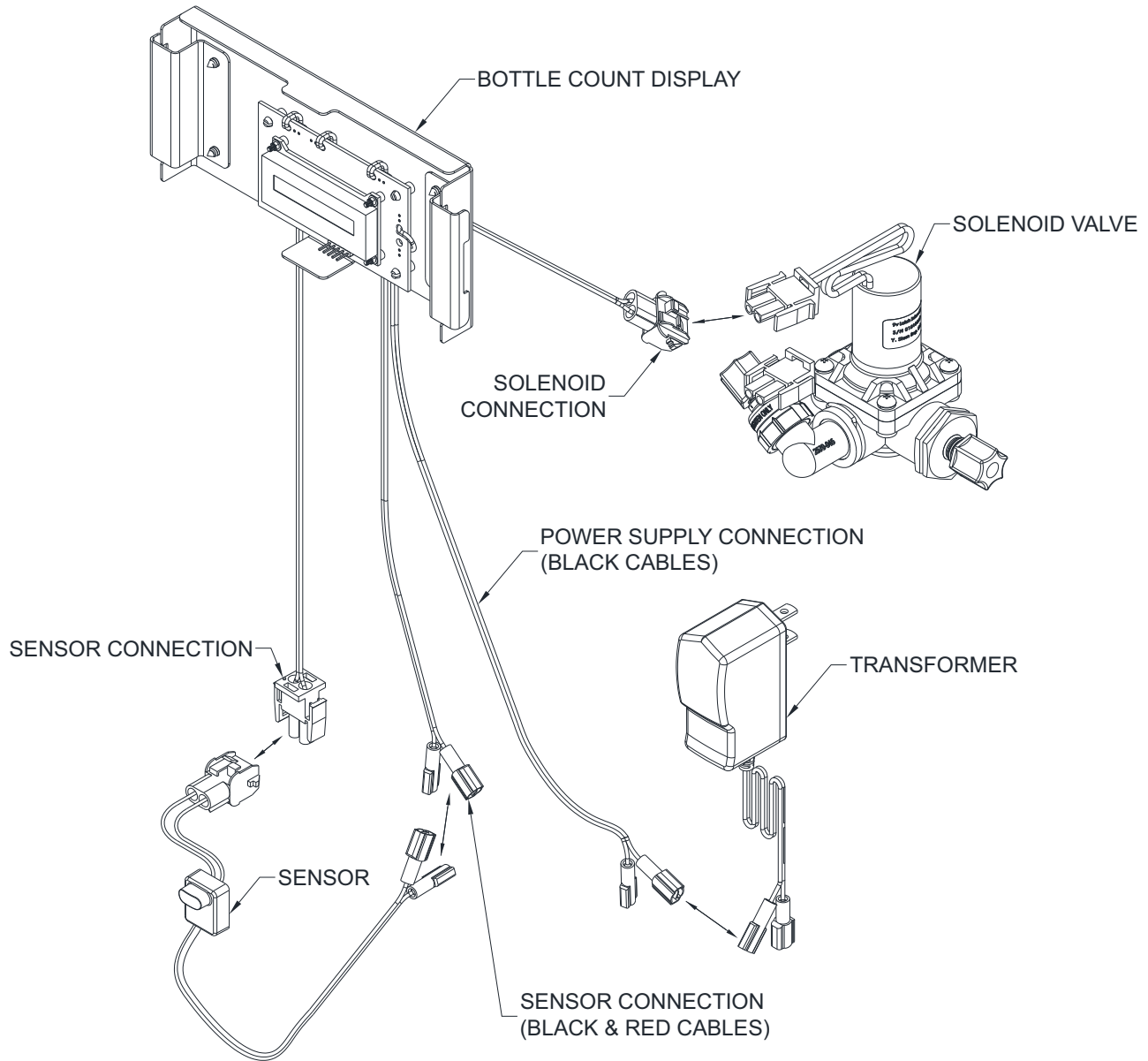



Semi-Recessed Bottle Fillers

INSTALLATION/MAINTENANCE INSTRUCTIONS

PUSH-IN FITTING INSTALLATION

NOTE: FITTINGS AND TUBE SHOULD BE KEPT CLEAN, BAGGED AND UNDAMAGED PRIOR TO INSTALLATION.

TO CUT TUBE:

Cut to fit length of 1/4" PE tubing and remove any burrs or sharp edges. Ensure that the outside diameter is free from score marks. Tube ends should be square.

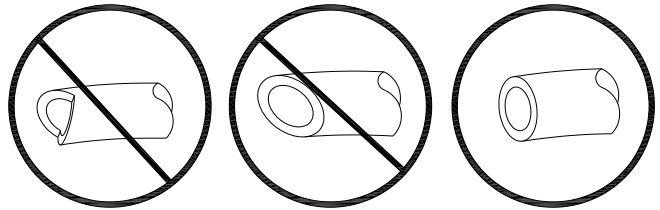

INSERTING THE TUBE:

1. Firmly and fully insert the tubing end into the push-in fitting up to the tube stop located approximately 1/2" deep.

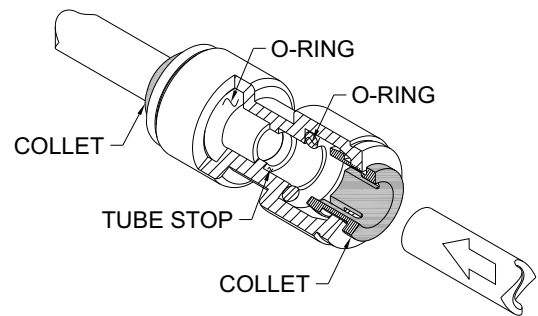

2. Pull on the fitted tubing to ensure it is secure. Tube should not come free from the fitting. Water test the connection assembly prior to leaving the site to ensure there are no leaks.

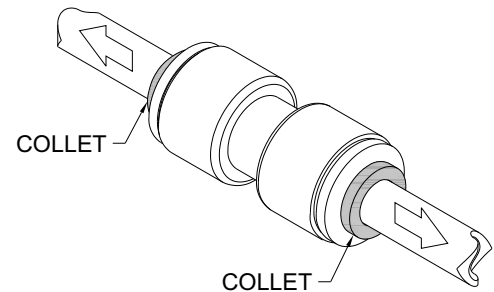

DISCONNECTING THE TUBE:

To disconnect the tube from the fitting ensure that the water line is depressurized. Push collet square towards the push-in fitting body and hold. While holding the collet in, pull on the PE tubing to remove from the push-in fitting.

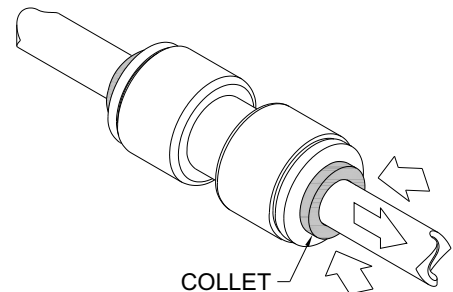



Semi-Recessed Bottle Fillers

INSTALLATION/MAINTENANCE INSTRUCTIONS

TROUBLE SHOOTING:

1. RESTRICTED OR NO WATER FLOW:

- a. Ensure Water Supply service stop valve is fully open.
- b. Verify minimum 20 psig supply line flow pressure.
- c. Check for twist or kinks in spout tubing.
- d. Check the water inlet "Y" strainer. Sediment from the main supply can get trapped in the screen along with installation materials such as pipe dope and flux. The screen should be cleaned and checked on a regular basis and replace if needed.
- e. Flow control in solenoid valve outlet elbow clogged remove & clean.

SENSOR TROUBLE SHOOTING:

1. IF LIGHT WITHIN SENSOR DOES NOT FLASH ONCE WHEN USER IS WITHIN RANGE:

- a. Verify 9VDC output of battery pack.
- b. Replace defective batteries.
- c. Sensor in "Security Mode" after 30 seconds of constant detection. Remove source of detection and wait 30 second before checking.
- d. Sensor is picking up a highly reflective surface. Eliminate cause of reflection and wait 30 seconds before checking.

2. IF LIGHT WITHIN SENSOR LENS FLASHES ONCE WHEN THE USER IS WITHIN RANGE:

- a. Repair bad connection from sensor to solenoid.
- b. There is debris or scale in the solenoid assembly. Remove solenoid, pull out plunger and spring. Clean with scale remover solution.
- c. There is debris or scale in center or two holes in convolution of the water diaphragm. Remove and clean.

CLEANING & MAINTENANCE GUIDE:

For Powder coated units: Units should be cleaned using a mild soap solution with a sponge or cotton cloth. Wipe down surfaces then rinse with clean water.

For Stainless steel units:

1. To Remove water spots or rust spots, stainless steel cleaner/polish on a cloth is recommended.
2. If there are stubborn spots or if you wish to treat a scratch, synthetic abrasive general purpose pads such as scotch brite are recommended.
3. Apply stainless steel cleaner/ polish to the synthetic abrasive pads and carefully rub the panel with the grain.
4. DO NOT use harsh chemicals, abrasive or petroleum based cleaners. Use of these will void the Acorn warranty. DO NOT use abrasives on powder coated units.
5. Stainless steel should be kept clean at all times. If a coating of stainless steel cleaner/ polish is maintained, stainless steel surfaces will retain their new, clean, polished appearance indefinitely.
6. Periodically remove access panel of cooler and clean out inline "Y" strainer



Semi-Recessed Bottle Fillers

INSTALLATION/MAINTENANCE INSTRUCTIONS

OPTIONAL -BAT BATTERY REPLACEMENT:

1. Unlock and swing open bottle filler door and remove battery pack from placed location. Do not disconnect the wires from the battery pack unless necessary.
2. Replace the six alkaline AA batteries while observing polarity.
3. Place the battery pack back to mounted location and test for proper operation. Then close bottle filler door and lock.

WIRING DIAGRAM:

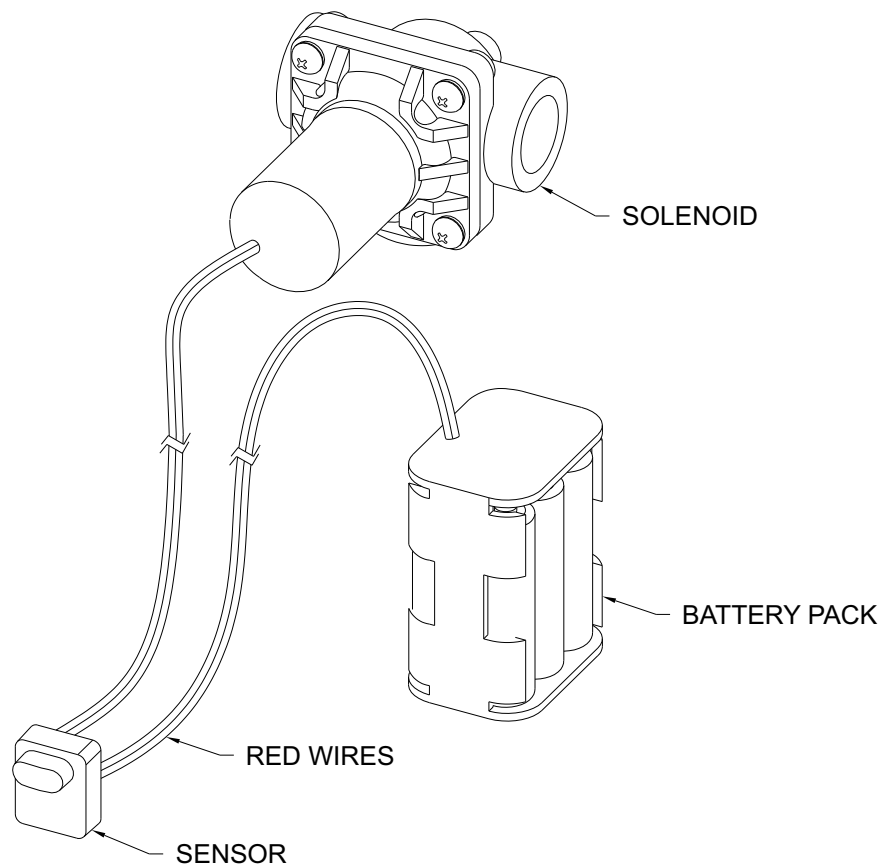



Semi-Recessed Bottle Fillers

INSTALLATION/MAINTENANCE INSTRUCTIONS

BF38 PARTS LIST

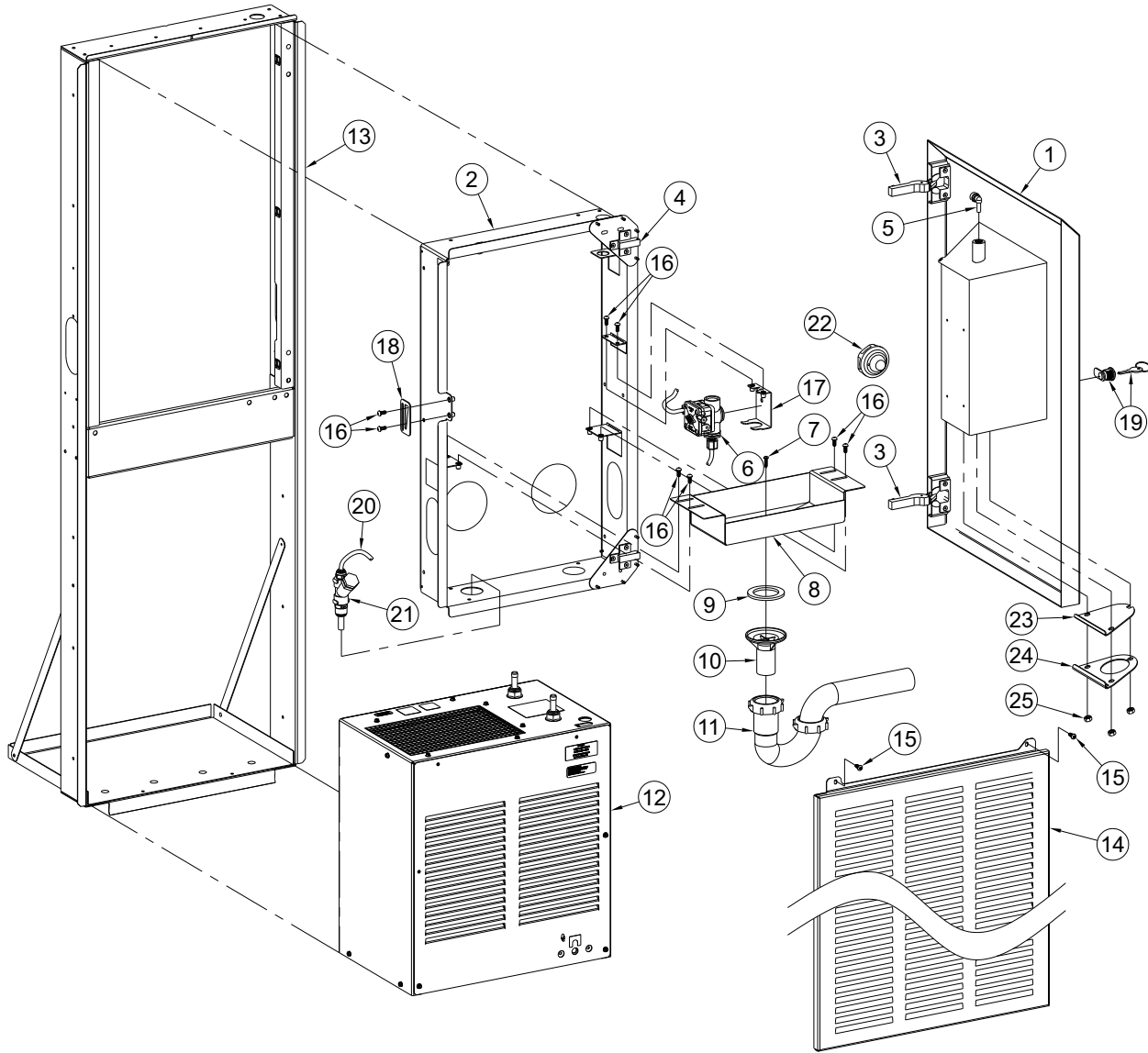

ITEM	PART NUMBER	DESCRIPTION	ITEM	PART NUMBER	DESCRIPTION
1	7013-139-001	FRONT PANEL ASSEMBLY	14	7013-201-199	VENTED PANEL
2	7013-109-001	MOUNTING FRAME ASSEMBLY	15	0112-021-000	#10-32 x 1/2" S/S HEX BTN HD SCREW
3	6354-012-000	INSERT CLIP HINGE	16	0116-003-000	#10-32 x 1/2" S/S PHIL HD SCREW
4	6354-020-000	OMM CLIP BASE PLATE	17	7013-125-001	AIR-CONTROL VALVE BRACKET
5	1895-709-000	1/4" PUSH-IN ELBOW	18	7013-118-199	LATCH ADJUSTMENT BRACKET
6	7013-137-001	AIR CONTROL VALVE ASSEMBLY	19	7013-108-003	CYLINDER LOCK AND KEY ASSEMBLY
7	0110-004-000	#8-3/4" PAN HEAD SCREW	20	2169-000-000	1/4" O.D. BLUE TUBING
8	7013-102-002	DRAIN TRAY	21	7000-021-001	"Y" STRAINER ASSEMBLY
9	7000-006-000	DRAIN ADAPTER GASKET	22	2566-150-001	HEMISPHERICAL PUSHBUTTON
10	7003-186-199	1-1/4" x 2-3/4" PLASTIC DRAIN TUBE	23	7013-103-199	MESH SCREEN
11	4970-265-000	1-1/4" P-TRAP	24	7013-114-199	SCREEN RING
12	7008-010-001	8GPH CHILLER ASSEMBLY	25	0302-005-000	1/4-20 UNC STN. STL. HEX NUT
13	7013-205-001	MF10 FRAME ASSEMBLY			



Semi-Recessed Bottle Fillers

INSTALLATION/MAINTENANCE INSTRUCTIONS

BF48 PARTS LIST

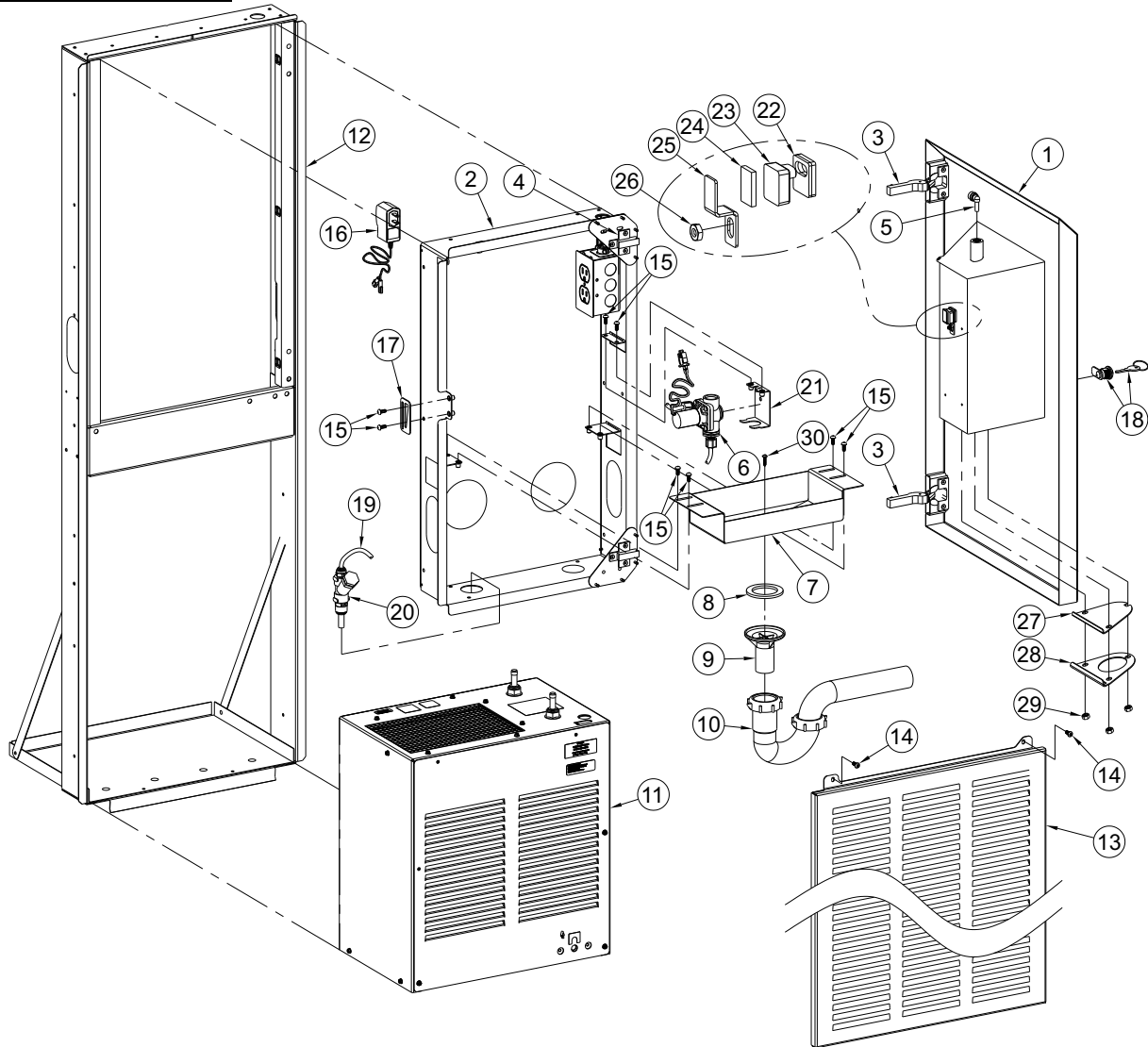

ITEM	PART NUMBER	DESCRIPTION	ITEM	PART NUMBER	DESCRIPTION
1	7013-108-001	FRONT PANEL ASSEMBLY	16	0710-730-001	9V PLUG-IN TRANSFORMER
2	7013-109-001	MOUNTING FRAME ASSEMBLY	17	7013-125-001	VALVE BRACKET ASSEMBLY
3	6354-012-000	INSERT CLIP HINGE	18	7013-108-003	CYLINDER LOCK ASSEMBLY
4	6354-020-000	0MM CLIP BASE PLATE	19	2169-000-000	1/4" O.D. BLUE TUBING
5	1895-709-000	1/4" PUSH-IN ELBOW	20	7000-021-001	"Y" STRAINER ASSEMBLY
6	7013-133-001	VALVE ASSEMBLY	21	7013-125-001	SOLENOID BRACKET ASSEMBLY
7	7013-102-002	DRAIN TRAY	22	7013-009-001	NANO SENSOR SPACER
8	7000-006-000	DRAIN ADAPTER GASKET	23	7013-057-002	NANO SENSOR ASSY
9	7003-186-199	1-1/4" x 2-3/4" PLASTIC DRAIN TUBE	24	7013-019-199	FOAM TAPE
10	4970-265-000	1-1/4" P-TRAP	25	7013-010-199	NANO SENSOR BRACKET
11	7008-010-001	8GPH CHILLER ASSEMBLY	26	0302-003-000	#8-32 HEX NUT
12	7013-205-001	MF10 FRAME ASSEMBLY	27	7013-103-199	MESH SCREEN
13	7013-201-199	VENTED PANEL	28	7013-114-199	SCREEN RING
14	7013-128-199	#10-32 x 1/2" S/S HEX BTN HDSCREW	29	0302-005-000	1/4-20 UNC STN. STL. HEX NUT
15	0116-003-000	#10-32 x 1/2" S/S PHIL HD SCREW	30	0110-004-000	#8-3/4" PAN HEAD SCREW

MURDOCK MFG. • 15125 Proctor Avenue • City of Industry, CA 91746 USA
 Phone 800-453-7465 or 626-333-2543 • Fax 626-855-4860 • www.murdockmfg.com

Member of
 MORRIS GROUP INTERNATIONAL