



DRINKING FOUNTAINS INSTALLATION/MAINTENANCE INSTRUCTIONS

A481.8 Series Barrier Free, Wall Mounted Electric Drinking Fountain



A481408S-CUSP / A481408F / A481408S

**TECHNICAL ASSISTANCE TOLL FREE TELEPHONE NUMBER:
1.800.591.9360**

Technical Assistance Fax: 1.626.855.4894

NOTES TO INSTALLER:

1. Please leave this documentation with the owner of the fixture when finished.
2. Please read this entire booklet before beginning the installation.
3. Check your installation for compliance with plumbing, electrical and other applicable codes.

LIMITED WARRANTY - UNITED STATES & CANADA

Murdock warrants that every cooler, bottle filling station, packaged water chiller, fountain and accessory to be free from defects in material and workmanship under normal use for one (1) year from date of install or eighteen (18) months after the date of shipment from the factory, whichever comes first.

Murdock warrants the compressor and hermetically sealed refrigeration system, including cooling coil assembly when part of the hermetically sealed refrigeration system, to be free from defects in material and workmanship under normal use for an additional four (4) years from the end of the one (1) year period described above.

This warranty does not cover installation or labor charges and does not apply to materials, which have been damaged by other causes such as mishandling or improper care or abnormal use. The repair or replacement of the defective materials shall constitute the sole remedy of the Buyer and the sole remedy of Murdock under this warranty. Murdock shall not be liable under any circumstances for incidental, consequential or direct charges caused by defects in the materials, or any delay in the repair or replacement thereof. This warranty is in lieu of all other warranties expressed or implied. Product maintenance instructions are issued with each unit and disregard or non-compliance with these instructions will constitute an abnormal use condition and void the warranty. Stainless steel must be protected on job site during construction and must be properly maintained after the water has been introduced into the water cooler or drinking fountain, or Murdock's limited warranty is void.

LIMITED EXPORT WARRANTY - One year on parts only.

Murdock assumes no responsibility for use of void or suspended data. © Copyright Murdock, City of Industry, CA Member of Morris Group International. Please visit www.murdockmfg.com for most current specifications.

COMPLIES WITH
STANDARDS



NSF/ANSI 61



Test rating conditions are
compliant with ARI 1010.



Federal
Public Law
111-380
(No Lead)



Member of
MORRIS GROUP
INTERNATIONAL

MURDOCK
15125 Proctor Ave.
City of Industry, CA
91746 U.S.A.
Phone 800-591-9360
626-336-4561
Fax 626-855-4894

www.murdockmfg.com

7020-100-001

Date: 07/25/18



DRINKING FOUNTAINS

INSTALLATION/MAINTENANCE INSTRUCTIONS

ROUGHING-IN AND DIMENSIONAL DRAWING

Prior to roughing consult with local, state, and federal codes for proper mounting height.

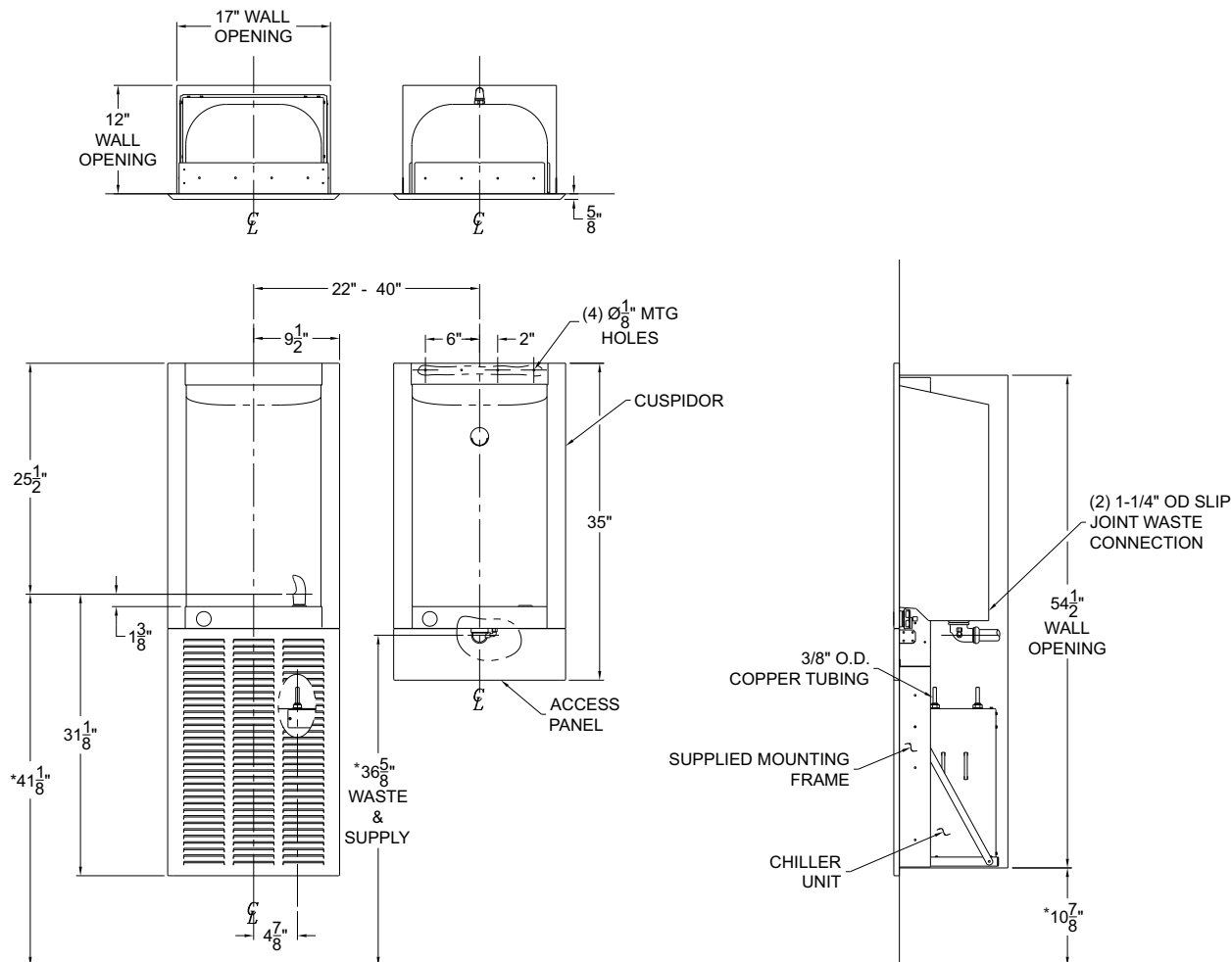

GENERAL NOTES:

1. ALL DIMENSIONS ARE IN INCHES.
- *2. DIMENSIONS SHOWN ARE FOR RECOMMENDED ADULT HEIGHT. ADJUST VERTICAL DIMENSIONS AS NECESSARY TO COMPLY WITH FEDERAL, STATE, & LOCAL CODES.
3. STOP VALVE NOT PROVIDED.

IMPORTANT:

1. Waste P-Trap and Water Supply Service Stop Valve to be supplied by others in accordance with local codes.
2. Water supply is 1/2" male NPSM (Cuspidor) & 3/8" copper tube (Fountain). See Figure "D". Waste is 1-1/4" OD female slip joint connection.
3. Completely flush supply lines of all foreign debris before connecting to fixture. Optional water filter is available should there be problems from the water supply with taste, odor, color, or sediment.
4. **WARNING:** Warranty is voided if installation is not made following current Acorn Aqua installation instructions and if components are assembled to the fixture that are not approved by Acorn Aqua.
5. Fixture operates within water pressure range of 20 to 105 psig. Acorn Aqua will not warranty fixtures damaged when connected to supply lines with flow pressure lower than 20 psig or higher than 105 psig. A pressure regulator must be furnished by others on supply line if inlet pressure is greater than 105 psig.



DRINKING FOUNTAINS

INSTALLATION/MAINTENANCE INSTRUCTIONS

INSTALLATION: A481408S-CUSP

1. Install Mounting Brackets to the bottom and top of the Rough-In opening for the Cuspidor unit.
WARNING: Mounting Brackets MUST be securely anchored and centered within the opening. See Figure B.
2. Install the Mounting Frame Assembly for the Chilled Fountain. Center the Frame Assembly and securely install per Rough-In number 7020-000-001.
3. Install the Air Valve Assembly roughly in position as shown in Figure B. This is supplied for the Cuspidor unit only and the installation method will be by others.
4. Hang the Cuspidor on the upper Mounting Bracket making sure the bracket and flange from Cuspidor engage. The Cuspidor must sit flush against the wall.
5. Locate the provided "L" brackets in relation to the Tabs from the Cuspidor. Mark the hole locations, remove the Cuspidor and then mount the brackets.
6. Install the captive nuts into the "L" brackets as shown in Figure C.
7. Re-hang the Cuspidor assembly. Secure the Cuspidor to the "L" brackets using the supplied #10-32 screws & washers. The screws need to pass through the tab and into the "L" brackets containing the captive nut. Tighten the screws to pull the Cuspidor flush with the wall.
8. Install water supply and drain as required per Figure A rough-in dimensions.
9. Make up 1-1/4" o.d. p-trap waste connection.
10. Place the Chiller Unit onto the basepan of the Fountain Frame Assembly.
11. Securely hang the Fountain Assembly on the top flange of the Frame Assembly making sure that the flanges engage.
12. Secure the Fountain to the Frame Assembly using the supplied #10-32 screws and washers. The screws need to pass through the tab and into the frame containing the captive nut. Tighten the screws to pull the Fountain flush with the wall.
13. Install water supply and drain as required per Figure A rough-in dimensions.
14. Make up 1-1/4" o.d. p-trap waste connection.
15. Thoroughly flush the supply line, connect water supply to the Fountain & Cuspidor.

INSTALLATION: A481408S & A481408F

1. Install the Mounting Frame Assembly for the Chilled Fountain. Center the Frame Assembly and securely install per Rough-In number 7020-000-001.
2. Place the Chiller Unit onto the base pan of the Fountain Frame Assembly.
3. Securely hang the Fountain Assembly on the top flange of the Frame Assembly making sure that the flanges engage.
4. Secure the Fountain to the Frame Assembly using the supplied #10-32 screws and washers. The screws need to pass through the tab and into the frame containing the captive nut. Tighten the screws to pull the Fountain flush with the wall.
5. Install water supply and drain as required per Figure A rough-in dimensions.
6. Make up 1-1/4" o.d. p-trap waste connection.
7. Thoroughly flush the supply line, connect water supply to the Fountain.

START UP:

1. Before assembling bottom covers to the Fountain & or Cuspidor, but after thoroughly flushing the supply line and connecting it to the fixture, turn on building water supply and check all connections for leaks.
2. Air within the Fountain & or Cuspidor or the structure supply piping will cause an irregular outlet stream until purged out by incoming water.
3. Recheck all water and drain connections with water flowing through system.
4. Install Removable Access Covers to the Fountain & or Cuspidor bottom Mounting Bracket, install the supplied #8-32 screws & washers from the bottom of the Removable Access Covers.



DRINKING FOUNTAINS

INSTALLATION/MAINTENANCE INSTRUCTIONS

PUSH-IN FITTING INSTALLATION

NOTE: FITTINGS AND TUBE SHOULD BE KEPT CLEAN, BAGGED AND UNDAMAGED PRIOR TO INSTALLATION.

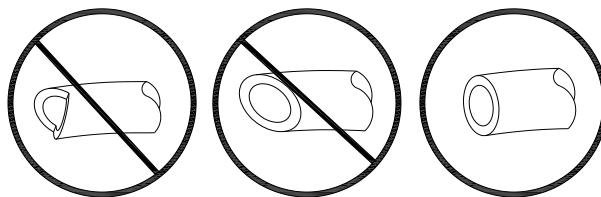

1. Cut to fit length of 1/4" PE tubing and remove any burrs or sharp edges. Ensure that the outside diameter is free from score marks. Tube ends should be square.

2. Firmly and fully insert the tubing end into the push-in fitting up to the tube stop located approximately 1/2" deep.

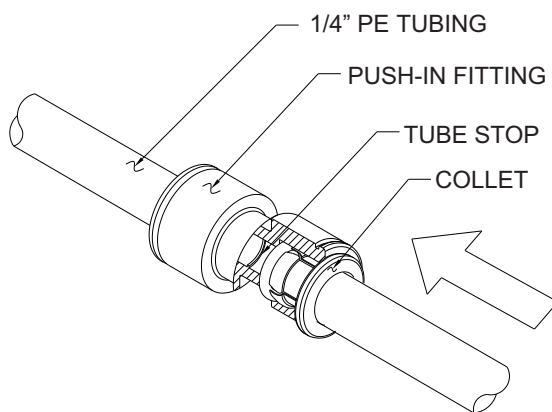

3. Pull on the fitted tubing to ensure it is secure. Tube should not come free from the fitting. Water test the connection assembly prior to leaving the site to ensure there are no leaks.

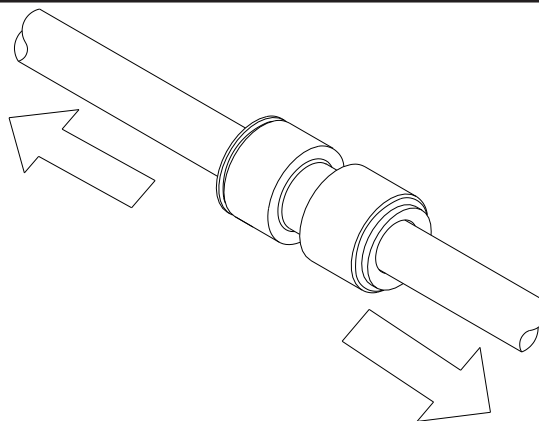

4. To disconnect the tube from the fitting ensure that the water supply is off. Push collet square towards the push-in fitting body and hold. While holding the collet in, pull on the PE tubing to remove from the push-in fitting.

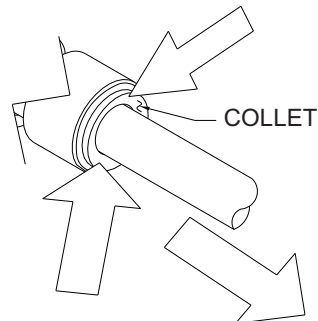

DRINKING FOUNTAINS

INSTALLATION/MAINTENANCE INSTRUCTIONS

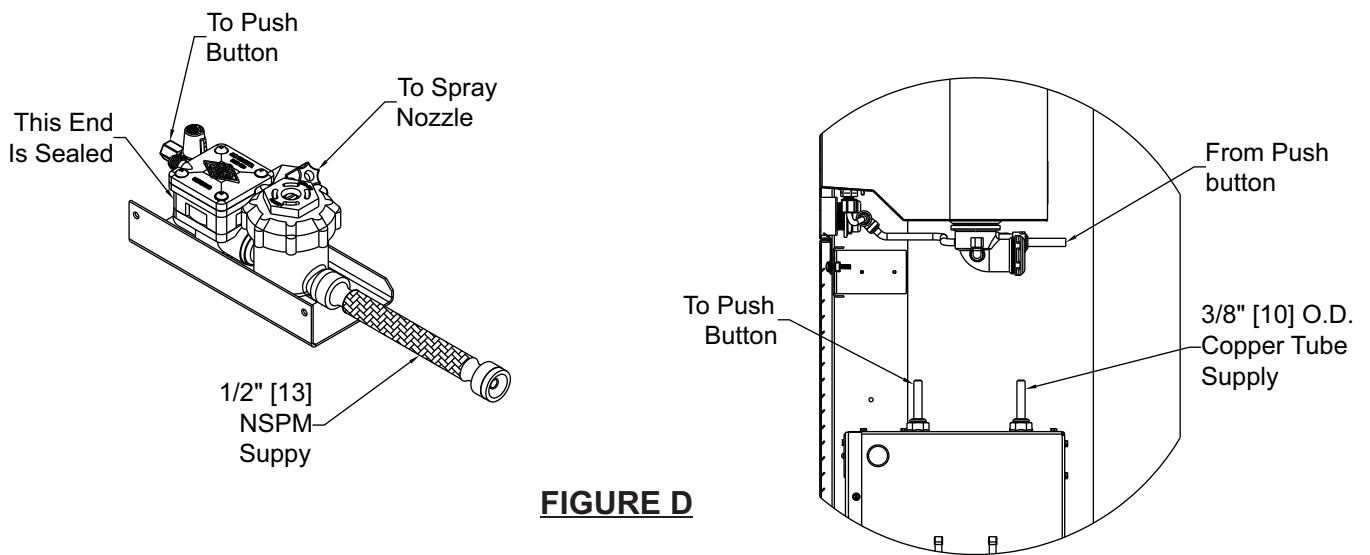
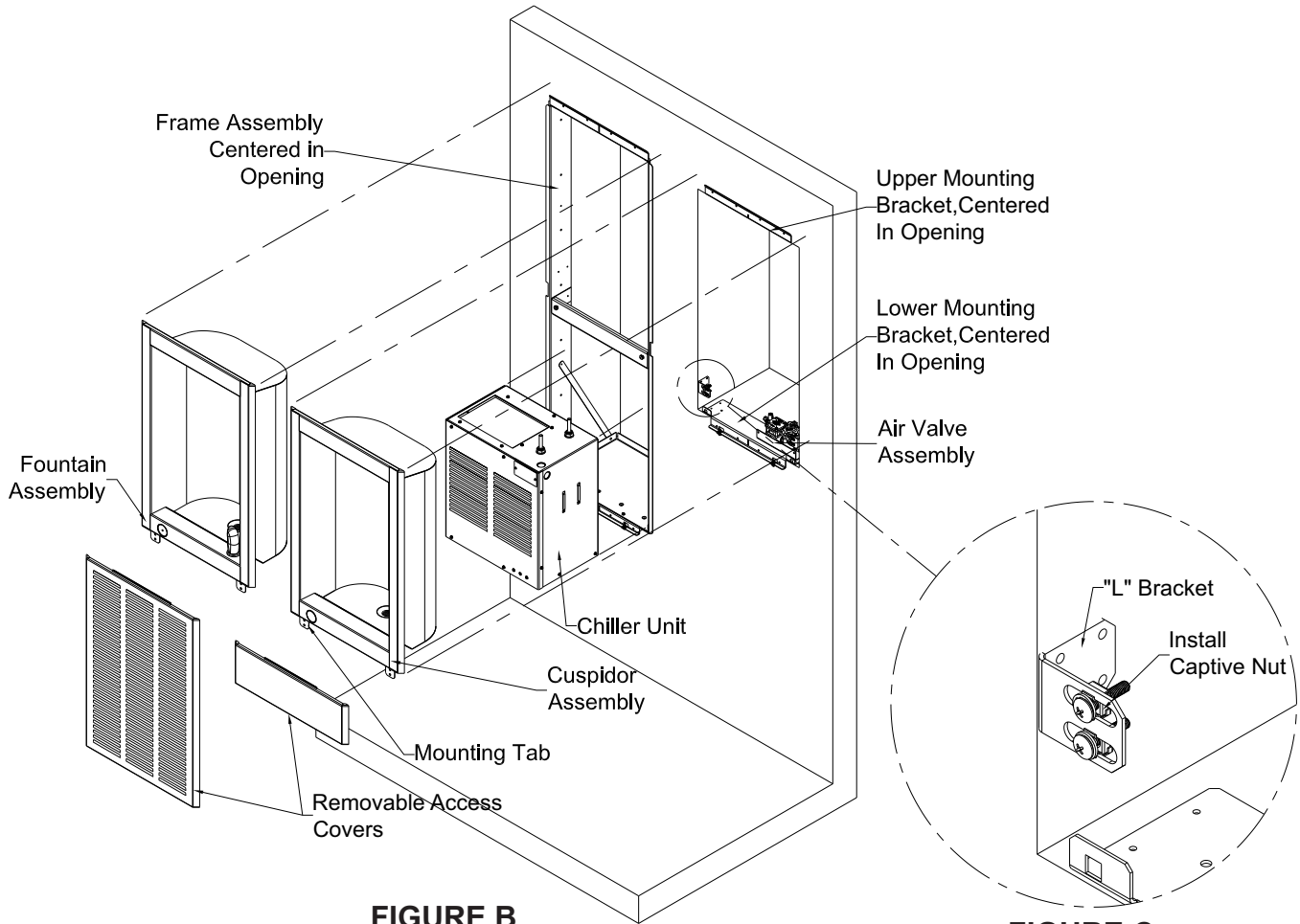



DRINKING FOUNTAINS

INSTALLATION/MAINTENANCE INSTRUCTIONS

A481408S-CUSP PART LIST:

ITEM #	PART NUMBER	DESCRIPTION
1	A0000000-MF6	CHILLED FOUNTAIN FRAME ASSEMBLY
2	7035-128-199	UPPER MOUNTING BRACKET
3	7035-117-199	L BRACKET
4	0316-020-000	CAPTIVE NUT
5	7035-412-001	CHECK STOP & AIR VALVE ASSY
6	7000-415-000	SELF RETAINING J NUT
7	7035-306-001	BRACKET, FRAME, LWR, FTN ONLY & ADA
8	7008-050-001	CHILLER UNIT
9	1720-010-000	REDUCING ELBOW
10	1896-002-000	1/4 COMPRESS FITTING
11	5200-151-001	SPRAY NOZZLE
12	0331-004-000	#10 FLAT WASHER
13	0321-011-000	#10 STAR WASHER
14	4926-055-001	GRID STRAINER W/ CLOSE ELL ASSY.
15	0116-006-000	#10-32 PHILLIPS SCREWS
16	7002-125-001	WELDED PUSHBUTTON/AIRTROIL VALVE ASSY
17	7002-125-002	PUSHBUTTON ASSY, AIR VALVE
18	7035-106-199	PANEL, LOWER, LONG,
19	0322-001-000	#8 PLATED STAR LOCK WASHER (EXTERNAL)
20	0279-002-000	#8-32 SOCKET CAP BUTTON HD SCREW 3/4" LG
21	7035-108-199	VENTED PANEL
22	7000-021-001	Y' STRAINER ASSEMBLY
23	7000-091-001	PUSHBUTTON W/ HEX ASSY
24	7000-060-000	FLOW REGULATOR CARTRIDGE (0.5 GPM)
25	7000-050-001	VALVE ASSEMBLY
26	7000-012-001	STAINLESS STEEL BUBBLER
	7000-410-002	LOW FLOW FLEX BUBBLER GRAY
27	7003-093-001	FLOW RESTRICTOR - LOW-FLOW BUBBLER ONLY

NOTE:
 ** Flow Restrictor Only Available
 With Low Flow Bubbler.

