

Location: _____



MC-51

**WALL MOUNTED LAVATORY
SUPPORT WITH CONCEALED ARMS**

Specification: MIFAB® Series MC-51 wall mounted concealed arm lavatory carrier with lacquered, adjustable, ductile iron concealed support arms. Complete with lacquered cast iron adjustable wall plate, adjustable steel nipples with locknut and set screws, and fixture leveling and locking hardware.

Function: Used to secure the fixture to the wall in areas where a floor mounted carrier cannot be installed. The wall structure must be strong enough to bear the weight of the fixture. The vertical load bearing components are concealed within the wall and the fixture carrier has no contact with the finished floor inside of the room.

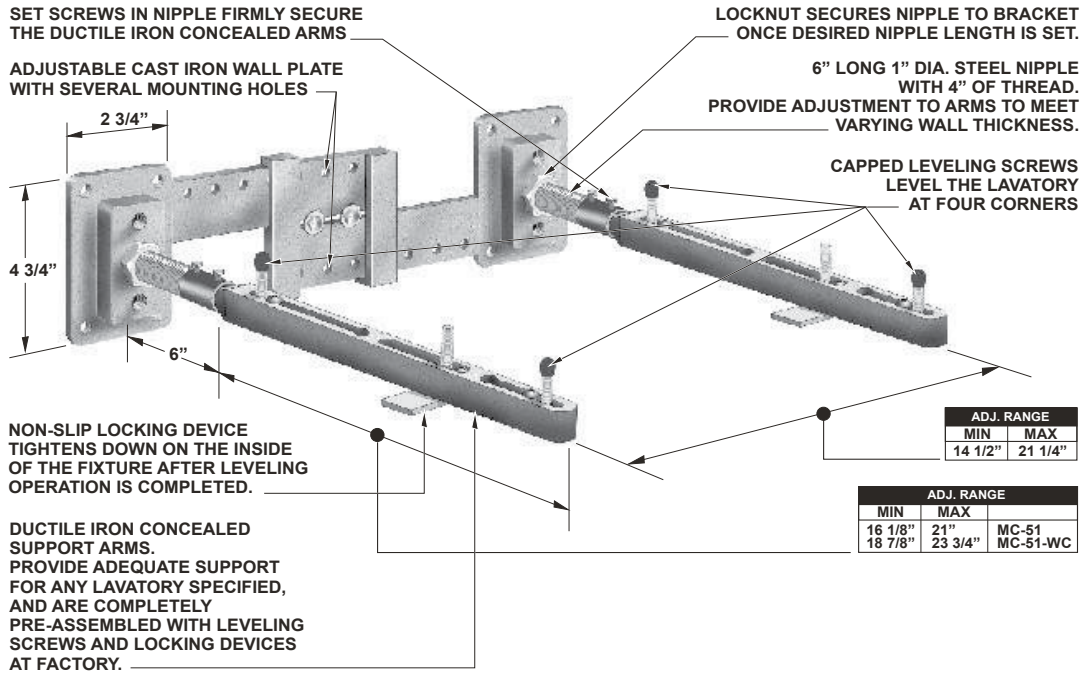

MC-51 Series Meets ANSI/ASME fixture carrier standard A112.6.1M-97

Note: Wall supported fixture mounting plates must be securely affixed (with suitable hardware by others) to a wall fully capable of bearing the weight of the plate and fixture.

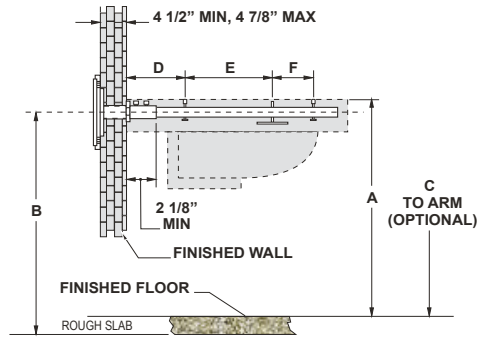
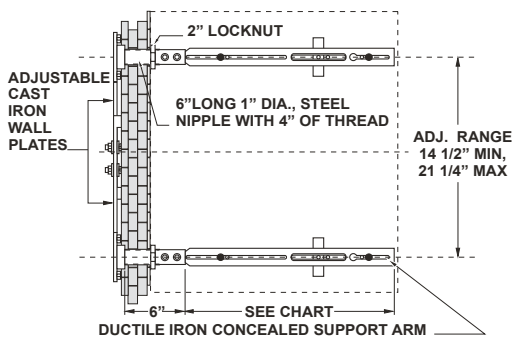

SUFFIX	OPTIONAL VARIATIONS
-A	Nipple length over 6" (specify)
-BA	Buy American Act compliant product
-E2	2" chrome plated escutcheons (pair)
-PA	Pennsylvania Steel Act compliant product
-WC	Paraplegic Rough-in

CALIFORNIA PROPOSITION 65 WARNING. This product contains chemicals known to the State of California to cause cancer and birth defects or other reproductive harm.

Job Name: _____ Page No: _____
 Section No: _____ Contractor: _____
 Schedule No: _____ Purchase Order No: _____