

Classic Series

MODEL M-C76E OLD STYLE TRI-LEVEL DRINKING FOUNTAIN

STANDARD FEATURES

Model M-C76E is a three station drinking fountain of Victorian-era design. This dual arm fountain includes a center fountain and bowls mounted on each arm to meet ADA requirements for wheelchair users. The fountain includes polished, cast brass bowls and stainless steel bubblers operated by separate stainless steel pushbutton control. Standard model is seasonal, not freeze resistant and includes a protective, high gloss, black enamel finish. Heavy-duty cast iron construction with cast brass bowl ensures trouble-free reliability. Field-serviceable components are easily accessible

SUGGESTED SPECIFICATIONS

Drinking fountain shall be Murdock model M-C76E. Unit shall be furnished with a center fountain bowl and two arms with one fountain bowl mounted per arm.

Pedestal and arms shall be a heavy duty iron casting and base of pedestal shall have four mounting holes. Pedestal shall be finished with a heavy grade of oil-based black enamel.

Bowls shall be round, solid brass casting. Unit shall be activated by self-closing pushbutton, needing less than 5 pounds of force, which activates an internally mounted valve with adjustable stream regulator controlling the water flow. Bubbler shall be stainless steel and operate on a water pressure range of 30 - 105 psig. All solid brass castings shall conform to ASTM standards B61 and B62. Unit shall conform to ANSI/NSF 61-9, and Public Law 111-380.



Standard Model: M-C76E

OPTIONS

(additional costs may be incurred)

- FRU3 Underground freeze-resistant valve for three bowls ¹
- FRU4 Underground freeze-resistant valve for four bowls ¹
- PF Pet fountain with pushbutton valve ¹
- Chrome plated cast brass bowl
- Powder-coated cast brass bowl
- Chrome plated bubbler
- **Black** Pedestal color black
- **Green** Pedestal color green

Options Notes:

¹ See separate option sheet.

² This option is not available freeze-resistant.

Custom color finishes available upon request.

Complies with the following standards:



Federal Public Law 111-380 (No Lead)



Member of U.S. Green Building Council



Recyclable Product



Water Conserving Product

WARNING: Cancer and Reproductive Harm - www.P65Warnings.ca.gov



TRADITIONAL DRINKING FOUNTAINS

Classic Series MODEL M-C76E OLD STYLE TRI-LEVEL DRINKING FOUNTAIN

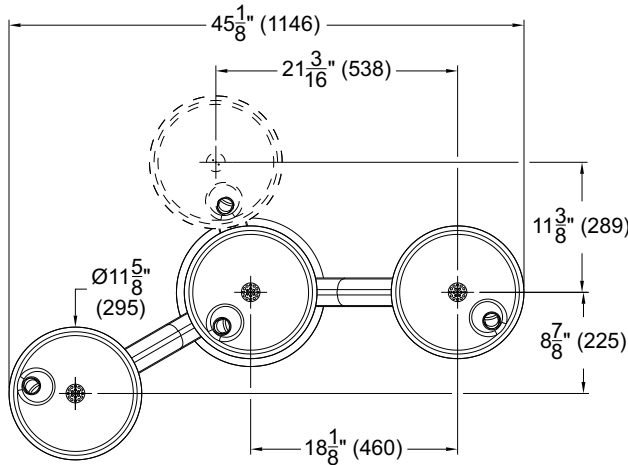

* Valve specifications:
Minimum/Maximum Pressure
30 to 100 psi

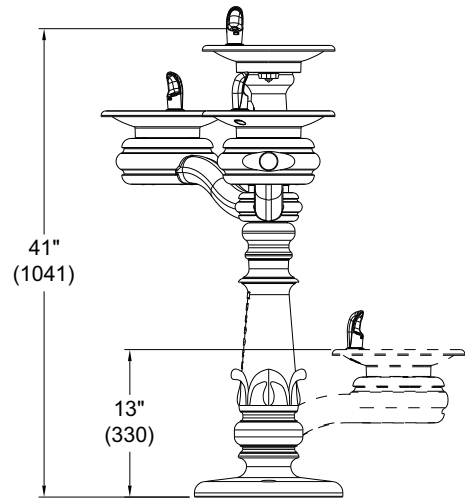
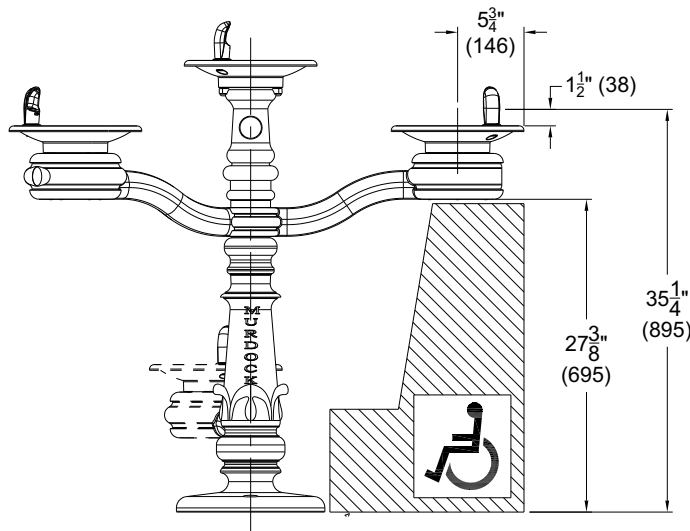
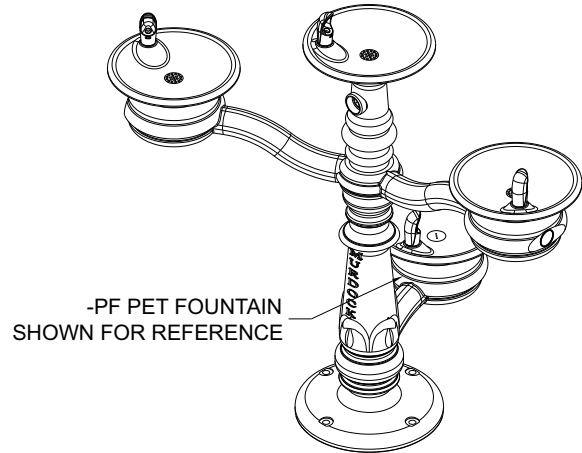

Murdock Mfg.™ warrants that its products are free from defects in material or workmanship under normal use and service for a period of one year from date of shipment. Murdock's liability under this warranty shall be discharged solely by replacement or repair of defective material, provided Murdock™ is notified in writing within one year from date of shipment, F.O.B. Industry, California.

SELECTION SUMMARY
& APPROVAL FOR
MANUFACTURING

Model Number & Options _____ Quantity _____

Company _____

Contact _____ Title _____

Signature (Approval for Manufacturing) _____ Date _____

All dimensions are subject to manufactures tolerance of plus or minus 1/2" nominal and subject to change without notice. Murdock assumes no responsibility for use of void or superseded data. Dimensions may change with the addition of optional accessories. Murdock Mfg.™, Member of Morris Group International™. Please visit www.murdockmfg.com for most current specifications.

MURDOCK MFG. • 15125 Proctor Avenue • City of Industry, CA 91746 USA
Phone 800-453-7465 or 626-333-2543 • Fax 626-855-4860 • www.murdockmfg.com

Member of
MORRIS GROUP
INTERNATIONAL