

SPECIFICATION:

JOSAM 17125-BB-UP-ADJ SERIES FLOOR-MOUNTED, BACK-TO-BACK LAVATORY CARRIER WITH FOUR CONCEALED ARMS, LEVELING AND SECURING SCREWS, TWO UPRIGHTS. DIMENSION C IS ADJUSTABLE AND TOP PLATES CAN ALSO BE SHIFTED LEFT OR RIGHT FROM CENTER AT JOB SITE.

LAVATORY CARRIER

FLOOR MOUNTED CONCEALED ARM
ADJUSTABLE BACK-TO-BACK STATION

SERIES **17125-BB-UP-ADJ**

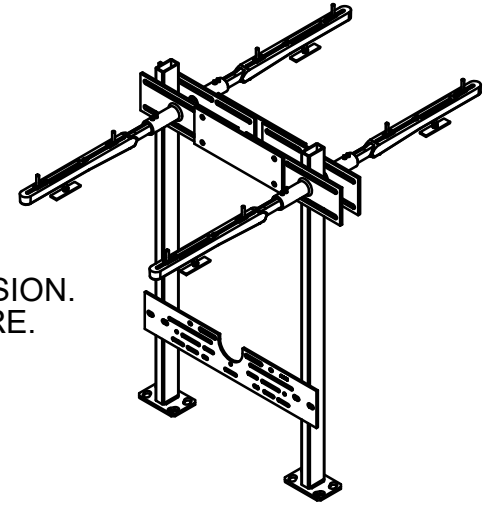
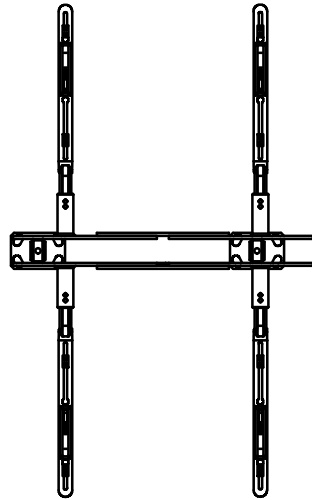

□: VARIABLE DIMENSION.
DEPENDS ON FIXTURE.

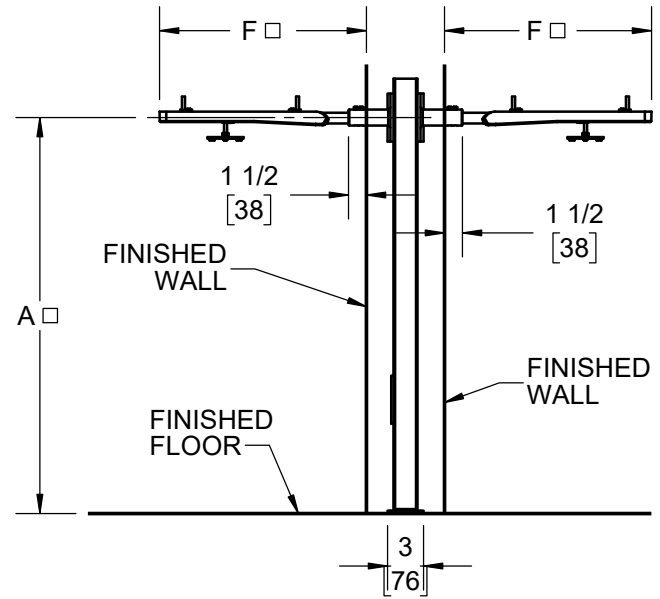
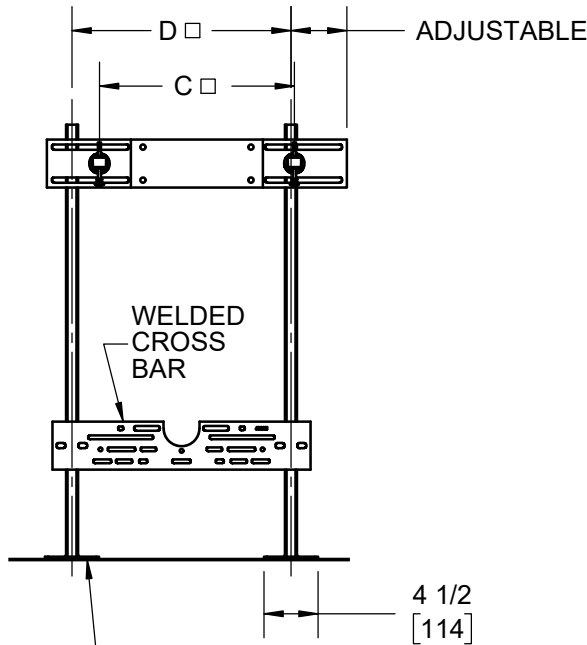

JOSAM RECOMMENDS FEET BE SECURED TO FLOOR WITH 1/2" BOLTS AND ANCHORS BY OTHERS

AUTHORIZED PROJECT SIGNATURE AND DATE:

NAME: _____

TITLE: _____

SIGNATURE: _____

DATE: _____

NOTE: ALL PRE-FAB CARRIERS ARE CUSTOM FABRICATED. ORDERS ARE NON-CANCELLABLE AND NON-RETURNABLE.

MANUFACTURER _____

NUMBER _____

SIZE _____

NAME _____

DIMENSIONS

A _____

C _____

D _____

F _____

RIM HEIGHT _____
BASED ON "A" DIM SHOWN

DATE OF LAST CHANGE: 05/25/18

DIMENSIONS ARE SUBJECT TO MANUFACTURERS TOLERANCES AND CHANGE WITHOUT NOTICE. WE CAN ASSUME NO RESPONSIBILITY FOR USE OF SUPERSEDED OR VOID DATA.



MICHIGAN CITY, INDIANA

NOTES

WARNING: Cancer and Reproductive Harm - www.P65Warnings.ca.gov